

OPERATING AND SERVICE MANUAL

HP 5384A and HP 5385A Frequency Counters

SERIAL PREFIX: 2436A

This manual applies to Serial prefix 2436A, unless accompanied by a Manual change Sheet indicating otherwise.

© Copyright HEWLETT-PACKARD COMPANY 1985
5301 STEVENS CREEK BOULEVARD, SANTA CLARA, CA 95051

MANUAL PART NUMBER 05384-90006
Microfiche Part Number 05384-90007

Printed: FEB 1987



TABLE OF CONTENTS

Section	Title	Page
I	GENERAL INFORMATION	1-1
	1-1. Introduction	1-1
	1-2. Manual Summary	1-1
	1-5. Specifications	1-1
	1-7. Safety Considerations	1-1
	1-10. Description	1-1
	1-27. Options	1-2
	1-33. Instrument Identification	1-2
	1-35. Accessories	1-2
	1-39. Recommended Test Equipment	1-2
II	INSTALLATION	2-1
	2-1. Introduction	2-1
	2-3. Unpacking and Inspection	2-1
	2-5. Preparation for Use	2-1
	2-6. Power Requirements	2-1
	2-8. Line Voltage Selection	2-1
	2-10. AC Line Fuse Selection	2-1
	2-12. DC Fuse Selection	2-1
	2-15. Power Cable	2-1
	2-17. HP-IB Interconnections	2-2
	2-21. HP-IB Talk/Listen Address Switch	2-2
	2-23. HP-IB Description	2-4
	2-25. HP-IL Interconnections (Option 003)	2-4
	2-27. HP-IB Description	2-4
	2-29. Channel B Input Fuse	2-4
	2-31. Operating Environment	2-4
	2-35. Storage and Shipment	2-4
	2-36. Environment	2-4
	2-39. Packaging	2-5
	2-42. Where to Ship Your Unit for Repair	2-5
	2-44. Field Installation of Options	2-6
	2-48. Option 001 (TCXO) Installation	2-6
	2-50. Option 003 HP-IL Installation	2-6
	2-52. Option 004 Oven Oscillator Installation	2-7
	2-54. Option 005 Battery Pack Installation	2-7
III	OPERATION AND PROGRAMMING	3-1
	3-1. Introduction	3-1
	3-3. Operating Characteristics	3-1
	3-6. Operating Instructions	3-1
	3-10. Operator's Maintenance	3-1
	3-13. General Operation Information	3-1
	3-14. Introduction	3-1
	3-16. Display	3-1
	3-19. Keyboard	3-2
	3-22. Inputs	3-2
	3-24. Power-Up/Self-Check	3-2
	3-28. Error Messages	3-2
	3-35. Front Panel Features	3-3
	3-38. ON-STBY	3-3

TABLE OF CONTENTS (Continued)

Section	Title	Page
III	OPERATION AND PROGRAMMING (Continued)	
	3-40. A Channel	3-3
	3-50. B Channel and A&B	3-4
	3-56. Gate and Display Digits	3-4
	3-67. Reset/Local and Check	3-5
	3-73. Inputs	3-6
	3-81. Rear Panel Features	3-6
	3-91. External DC Operation	3-7
	3-93. Making Frequency and Period Measurements	3-7
	3-95. Remote Programming	3-11
	3-96. Introduction	3-11
	3-101. Interface Description	3-11
	3-102. Hewlett-Packard Interface Bus (HP-IB)	3-11
	3-104. Hewlett-Packard Interface Loop (HP-IL)	3-11
	3-107. Interface Functional Overview	3-12
	3-111. Interface Systems Terms	3-12
	3-113. Address Selection	3-12
	3-118. Interface Commands	3-13
	3-121. Interface Capabilities	3-14
	3-125. Meta Messages	3-14
	3-130. SRQ, SRQ Mask, and Status Byte	3-15
	3-131. SRQ and Status Byte	3-15
	3-136. Service Request Mask	3-16
	3-138. Device Dependent Commands	3-16
	3-140. Output Formats	3-16
	3-143. Numeric Entry	3-17
	3-147. IN Initialize	3-17
	3-149. WA0 and WA1 Wait to Send Mode Off/On	3-17
	3-152. DR (string) Remote Display	3-18
	3-159. DL Display Local	3-18
	3-161. ID and SI Send Device ID	3-18
	3-163. SE Send Error	3-18
	3-165. LCD Character Set	3-18
	3-167. Program Examples	3-18
IV	PERFORMANCE TESTING	4-1
	4-1. Introduction	4-1
	4-3. Equipment Required	4-1
	4-5. Test Record	4-1
	4-7. Error Messages	4-1
	4-9. Performance Test	4-1
V	ADJUSTMENTS	5-1
	5-1. Introduction	5-1
	5-4. Equipment Required	5-1
	5-6. Adjustment Locations	5-1
	5-8. Safety Considerations	5-1
	5-10. HP 5384A/HP 5385A Adjustment Procedures	5-1
	5-11. HP 5384A/HP 5385A +3 Volt DC Adjustment Procedure	5-1
	5-13. HP 5384A/HP 5385A Channel A Input Amplifier Adjustment Procedure	5-2

TABLE OF CONTENTS (Continued)

Section	Title	Page
IV	ADJUSTMENTS (Continued)	
5-15.	HP 5384A Channel B Input Amplifier Adjustment Procedure	5-3
5-17.	HP 5385A Channel B Input Amplifier Adjustment Procedure	5-3
5-19.	Standard Oscillator Adjustment Procedures	5-5
5-21.	TCXO Adjustment Procedure	5-5
5-25.	Oven Oscillator Adjustment Procedure	5-7
5-26.	HP 5384A/HP 5385A Battery Charger Adjustment Procedure	5-7
VI	REPLACEABLE PARTS	6-1
6-1.	Introduction	6-1
6-3.	Abbreviations	6-1
6-5.	Replaceable Parts Lists	6-1
6-9.	Ordering Information	6-1
6-12.	Direct Mail Order System	6-1
VII	MANUAL CHANGES	7-1
7-1.	Introduction	7-1
7-3.	Manual Changes	7-1
VIII	SERVICE	8-1
8-1.	Introduction	8-1
8-3.	Schematic Diagram Symbols and Reference Designators	8-1
8-5.	Reference Designations	8-1
8-7.	Identification Markings on Printed Circuit Boards	8-1
8-11.	Safety Considerations	8-2
8-16.	Safety Symbols	8-2
8-18.	Recommended Test Equipment	8-2
8-20.	Service Aids	8-2
8-21.	Pozidriv Screwdrivers	8-2
8-23.	Nut Drivers	8-2
8-25.	Service Aids on Printed Circuit Boards	8-3
8-27.	After Service Safety Checks	8-3
8-32.	HP 5384A and HP 5385A Disassembly Procedures	8-3
8-35.	Assembly Identification	8-3
8-37.	Logic Symbols	8-5
8-39.	Explanation of New Logic Symbols	8-5
8-40.	Introduction	8-5
8-45.	Symbol Composition	8-5
8-52.	Qualifying Symbols	8-7
8-65.	Dependency Notation	8-10
8-125.	Bistable Elements	8-17
8-129.	Coders	8-18
8-137.	Use of Binary Grouping to Produce Affecting Inputs	8-19
8-139.	Sequence of Input Labels	8-20
8-144.	Sequence of Output Labels	8-20
8-151.	Theory of Operation	8-21
8-152.	Overall Counter Operation	8-21
8-167.	Signal Descriptions	8-23

TABLE OF CONTENTS (Continued)

Section	Title	Page
VIII	SERVICE (Continued)	
	8-169. Detailed Theory of Operation	8-23
	8-177. HP 5384A Channel B	8-24
	8-182. HP 5385A Channel B	8-25
	8-193. HP 3870 Microcomputer	8-25
	8-200. Interpolator Technique	8-26
	8-207. HP-IB	8-27
	8-213. HP-IL	8-28
	8-230. Power Supply	8-30
	8-246. Battery Pack Charger	8-31
	8-258. Troubleshooting	8-32
	8-259. Introduction	8-32
	8-263. Built-In Diagnostics	8-33
	8-265. Accessing the Built-In Diagnostics	8-33
	8-269. Power-Up Self-Check	8-33
	8-272. CPU Check	8-33
	8-275. I/O Address	8-33
	8-278. Interpolator, Long and Short Calibration	8-34
	8-283. Microprocessor Port Check	8-34
	8-286. Manual Troubleshooting	8-34
	8-288. Power Supply Troubleshooting	8-35
	8-289. Oscillator Troubleshooting	8-35
	8-293. Input Amplifier Troubleshooting	8-36
	8-301. Battery Pack Troubleshooting	8-41
	8-303. Battery Charger Board Troubleshooting	8-41
	8-309. Battery Load Current Test	8-41
	8-311. Shut-Down Voltage Test	8-42
	8-313. Battery Tests	8-42
	8-315. Charge State	8-42
	8-318. Capacity Test	8-42
	8-320. HP-IB Interface Assembly (A5 Board) Troubleshooting	8-43

LIST OF TABLES

Title	Title	Page
1-1.	Models HP 5384A and HP 5385A Specifications	1-3
1-2.	Recommended Test Equipment	1-5
2-1.	HP-IB Cable Descriptions	2-2
2-2.	HP-IL Cable Descriptions	2-4
3-1.	Power-Up Initialize States	3-2
3-2.	Error Messages	3-3
3-3.	Units Display Format	3-7
3-4.	Address Selection	3-13
3-5.	Interface Capabilities	3-14
3-6.	Meta Messages	3-15
3-7.	Meta Messages and Controller Commands	3-15
3-8.	HP 5384A and HP 5385A Status Byte	3-16
3-9.	Instrument Command Set	3-17
3-10.	LCD Character Set	3-25
4-1.	Performance Test	4-1
5-1.	Adjustments	5-1
5-2.	Approximate Offset Determination Table	5-6
6-1.	Abbreviations and Reference Designations	6-2
6-2.	HP 5384A Replaceable Parts	6-3
6-3.	HP 5384A with TCXO Replaceable Parts	6-8
6-4.	HP 5384A with Oven Oscillator Replaceable Parts	6-13
6-5.	Front Panel Display Assembly Replaceable Parts	6-18
6-6.	Battery Pack Replaceable Parts	6-19
6-7.	HP-IL Replaceable Parts	6-20
6-8.	HP-IB Replaceable Parts	6-21
6-9.	HP 5385A Replaceable Parts	6-22
6-10.	HP 5385A with Oven Oscillator Replaceable Parts	6-28
6-11.	Manufacturers Code List	6-33
6-12.	HP 5384A Replaceable Mechanical Parts	6-34
6-12.	HP 5385A Replaceable Mechanical Parts	6-36
7-1.	Manual Backdating	7-1
8-1.	Assembly Usage	8-3
8-2.	General Qualifying Symbols	8-6
8-3.	Qualifying Symbols for Inputs and Outputs	8-7
8-4.	Symbols Inside the Outline	8-9
8-5.	Summary of Dependency Notation	8-10
8-6.	Signal Descriptions	8-23
8-7.	Power Supplies and Associated Assemblies	8-35
8-8.	Battery Pack Troubleshooting	8-41
8-9.	Battery State-of-Charge	8-43

LIST OF FIGURES

Figure	Title	Page
1-1.	Models HP 5384A and HP 5385A Frequency Counters and Accessories	1-0
2-1.	Line Voltage Selection	2-1
2-2.	Power Cable HP Part Number versus Mains Plugs Available	2-2
2-3.	Hewlett-Packard Interface Bus Connections	2-3
2-4.	Typical HP-IL Interface Connection	2-4
2-5.	Details of Input Connector J2 and Fuse Mounting	2-5
3-1.	Front Panel ON/STBY Switch	3-3
3-2.	Front Panel A Channel Function Keys	3-3
3-3.	Front Panel B and A&B Function Keys	3-4
3-4.	Front Panel Gate Selection Display Digits Keys	3-5
3-5.	Front Panel Reset/Local and Check Keys	3-5
3-6.	Front Panel Inputs Section	3-6
3-7.	Front Panel Indicators	3-8
3-8.	Front Panel Controls	3-9
3-9.	Rear Panel Features	3-10
3-10.	HP 5384A and HP 5385A Address Switches Shown in Address 31	3-12
3-11.	Typical HP-IL System Addressing	3-13
3-12.	Example 5 Set-Up	3-22
5-1.	Assembly Adjustment Locator	5-2
5-2.	Channel A Input Amplifier Adjustment Setup	5-3
5-3.	Input Amplifier Adjustment Waveform	5-3
5-4.	HP 5384A Channel B Input Amplifier Adjustment Setup	5-4
5-5.	HP 5385A Channel B Input Amplifier Adjustment Setup	5-4
5-6.	Standard, TCXO and Oven Oscillator Test Setup	5-5
5-7.	TCXO and Standard Oscillator Adjustment	5-6
5-8.	Standard Oscillator Coarse and Fine Adjustment Location	5-6
5-9.	Fast Charge Current Adjustment Setup	5-7
5-10.	Fast Charge Threshold Adjustment Setup	5-8
6-1.	HP 5384A Exploded View	6-35
6-2.	HP 5385A Exploded View	6-37
8-1.	Schematic Diagram Notes	8-4
8-2.	Test Setup for A3C37 and C23 Selection	8-5
8-3.	Illustration of Common-Control Block	8-6
8-4.	Illustration of Common-Output Element	8-6
8-5.	G Dependency Between Inputs	8-11
8-6.	G Dependency Between Outputs and Inputs	8-11
8-7.	G Dependency with A Dynamic Input	8-11
8-8.	OR'ed Affecting Inputs	8-12
8-9.	Substitution for Numbers	8-12
8-10.	V (OR) Dependency	8-12
8-11.	N (Negate, X-OR) Dependency	8-12
8-12.	Z (Interconnection) Dependency	8-13
8-13.	X (Transmission) Dependency	8-14
8-14.	C (Control) Dependency	8-14

LIST OF FIGURES (Continued)

Figure	Title	Page
8-15.	S (Set) and R (Reset) Dependencies	8-14
8-16.	EN (Enable) Dependency	8-15
8-17.	M (Mode) Dependency	8-15
8-18.	Type of Flip-Flop Determined by Mode	8-16
8-19.	Disabling an Output of the Common Control Block	8-16
8-20.	Determining an Output Function	8-16
8-21.	Dependent Relationship Affected by Mode	8-16
8-22.	A (Address) Dependency	8-17
8-23.	RAM Example	8-17
8-24.	Four Types of Bistable Circuits	8-18
8-25.	Code General Symbol	8-18
8-26.	An X-Y Code Converter	8-18
8-27.	An X-Octal Code Converter	8-19
8-28.	Coder Producing Several Dependencies	8-19
8-29.	Code Producing One Type of Dependency	8-19
8-30.	Use of Binary Grouping Symbol	8-19
8-31.	Input Lables	8-20
8-32.	Factoring Input Lables	8-20
8-33.	Placement of Three-State Symbols	8-20
8-34.	Output Labels	8-21
8-35.	Factoring Output Labels	8-21
8-36.	HP 5384A/HP 5385A Block Diagram	8-22
8-37.	Interpolator Timing Diagram	8-26
8-38.	Expanded Interpolator Error Pulse	8-26
8-39.	Short and Long Calibration Pulses Example	8-27
8-40.	Sample HP-IL Frame	8-29
8-41.	HP-IL Bit Encoding	8-29
8-42.	Open Circuit Output Waveform	8-30
8-43.	Standard Oscillator Waveform	8-35
8-44.	Option 001 (TCXO) Oscillator Waveform	8-36
8-45.	HP 5384A/HP 5385A Channel A Waveforms	8-37
8-46.	HP 5384A Channel B Waveforms	8-38
8-47.	HP 5385A Channel B Waveforms	8-40
8-48.	All Signatures for the HP 5384A and HP 8385A Motherboard	8-44
8-49.	Troubleshooting Flowchart	8-45
8-50.	HP 5384A A1 Motherboard Assembly (Sheet 1 of 2)	8-47
8-50.	HP 5384A A1 Motherboard Assembly (Sheet 2 of 2)	8-49
8-51.	HP 5385A A1 Motherboard Assembly (Sheet 1 of 2)	8-51
8-51.	HP 5385A A1 Motherboard Assembly (Sheet 2 of 2)	8-53
8-52.	A4 HP-IB Interface Assembly	8-55
8-53.	A5 HP-IL Interface Assembly	8-57
8-54.	A3 Battery Pack Assembly	8-59

SAFETY CONSIDERATIONS

GENERAL

This product and related documentation must be reviewed for familiarization with safety markings and instructions before operation.

This product is a Safety Class I instrument (provided with a protective earth terminal).

BEFORE APPLYING POWER

Verify that the product is set to match the available line voltage and the correct fuse is installed. Refer to Section II, Installation.

SAFETY EARTH GROUND

An uninterruptible safety earth ground must be provided from the mains power source to the product input wiring terminals or supplied power cable.

SAFETY SYMBOLS



Instruction manual symbol; the product will be marked with this symbol when it is necessary for the user to refer to the instruction manual.



Indicates hazardous voltages.

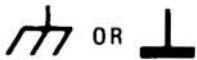

Indicates terminal is connected to chassis when such connection is not apparent.



Alternating current.



Direct current.

WARNING

The **WARNING** sign denotes a hazard. It calls attention to a procedure, practice, or the like, which, if not correctly performed or adhered to, could result in personal injury. Do not proceed beyond a **WARNING** sign until the indicated conditions are fully understood and met.

CAUTION

The **CAUTION** sign denotes a hazard. It calls attention to an operating procedure, practice, or the like, which, if not correctly performed or adhered to, could result in damage to or destruction of part or all of the product. Do not proceed beyond a **CAUTION** sign until the indicated conditions are fully understood and met.

SAFETY INFORMATION

WARNING

Any interruption of the protective grounding conductor (inside or outside the instrument) or disconnecting the protective earth terminal will cause a potential shock hazard that could result in personal injury. (Grounding one conductor of a two conductor outlet is not sufficient protection.)

Whenever it is likely that the protection has been impaired, the instrument must be made inoperative and be secured against any unintended operation.

If this instrument is to be energized via an autotransformer (for voltage reduction) make sure the common terminal is connected to the earthed pole terminal (neutral) of the power source.

Instructions for adjustments while covers are removed and for servicing are for use by service-trained personnel only. To avoid dangerous electric shock, do not perform such adjustments or servicing unless qualified to do so.

For continued protection against fire, replace the line fuse(s) only with 250V fuse(s) of the same current rating and type (for example, normal blow, time delay). Do not use repaired fuses or short circuited fuseholders.

HP 5384A and HP 5385A
General Information



Model HP 5384A

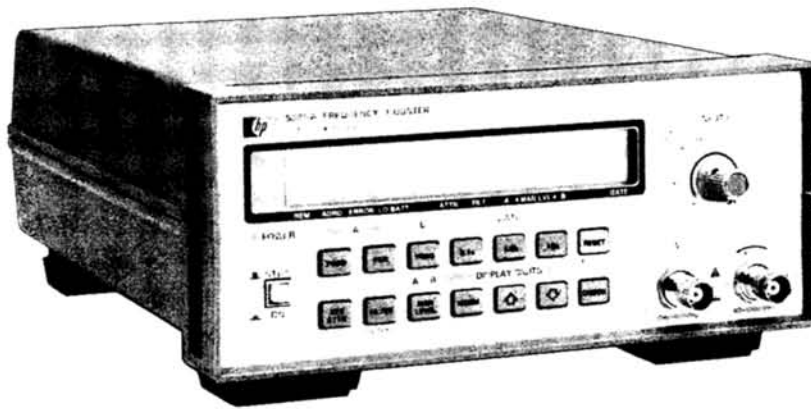

Model HP 5385A



Power Cord

Figure 1-1. Models HP 5384A and HP 5385A Frequency Counters and Accessories

SECTION I GENERAL INFORMATION

1-1. INTRODUCTION

1-2. This manual provides you with information pertaining to the installation, operating, programming, performance tests, adjustments, and maintenance of the Hewlett-Packard Models 5384A and 5385A Frequency Counters, shown in *Figure 1-1*.

1-3. MANUAL SUMMARY

1-4. The manual is divided into eight sections, each covering a particular topic for the operation of the HP 5384A and HP 5385A Frequency Counters. The topics by section number are:

Section	Topic
I	General Information
II	Installation
III	Operation and Programming
IV	Performance Tests
V	Adjustments
VI	Replaceable Parts
VII	Manual Changes
VIII	Service

1-5. SPECIFICATIONS

1-6. The instrument specifications and option specifications are listed in *Table 1-1*. These specifications are performance standards or limits against which the instrument may be tested.

1-7. SAFETY CONSIDERATIONS

1-8. This is a Safety Class I instrument. This instrument has been designed and tested according to international safety requirements.

1-9. This manual contains information, cautions, and warnings which must be followed by operating and service personnel to ensure safe operation and to retain the instrument in safe condition.

1-10. DESCRIPTION

1-11. The Hewlett-Packard Models 5384A and 5385A are frequency counters that make frequency and period measurements. The HP 5384A has a frequency range of 10 Hz to 225 MHz, and the HP 5385A has a frequency range of 10 Hz to 1000 MHz. Both counters are microcomputer based instruments with a data bus port for remote operation through either HP-IL or HP-IB.

1-12. Both counters have "A" and "B" input channels with BNC type connectors.

1-13. Above the "A" and "B" input connectors is a dual purpose control that allows you to either set the trigger level of Channel A or adjust the input attenuation of Channel B.

1-14. A 100 kHz low pass filter can be toggled in or out of the Channel A signal path on either counter.

1-15. Measurement display and mode annunciators are shown on a 12-character alphanumeric liquid crystal display (LCD). Frequency and period measurements are displayed in engineering format, with three alpha characters used to designate units, e.g., MHz. The display will also give you brief messages and diagnostic prompts.

1-16. The HP 5384A and HP 5385A are designed so you may either rack mount or stack them.

1-17. A 10 MHz reference oscillator output is included in both counters. The connector for the 10 MHz output may also be used as an external 10 MHz reference oscillator input connection.

1-18. Option 001 is a temperature compensated crystal oscillator (TCXO). The TCXO is an option in the HP 5384A and standard in the HP 5385A.

1-19. A jack for connecting external dc power is provided on the rear panel and Option 005 battery pack can be installed to provide mobility.

1-20. Option 003 is the Hewlett-Packard Interface Loop (HP-IL) for remote control of the counters by battery operated controllers such as the HP41C/CV hand held controller.

1-21. Option 004 is an ovenized oscillator that provides a high stability time base giving substantially higher accuracy over variations in time and temperature.

1-22. Option 005 is a battery pack that provides portable operation of the HP 5384A or HP 5385A.

1-23. HP-IB is the Hewlett-Packard Interface Bus for remote control of the counters by computers and controllers. It is a standard feature in the instrument.

1-24. The HP-IB, (Hewlett-Packard Interface Bus) is Hewlett-Packard's implementation of IEEE Standard 488-1978 and ANSI Standard MC 1.1. HP-IB is a high-speed parallel interface bus. All devices on the bus are capable of being addressed at one time. However, only one device may respond at a time. A controller is used to command which device responds. (The HP 5384A or HP 5385A with HP-IB would make measurements and return data upon commands from a controller.)

1-25. The counter can be configured for either HP-IB or HP-IL, not both.

1-26. HP-IB or HP-IL allows the HP 5384A and HP 5385A to output data to other devices or, on a more complex level, respond to remote programming instructions to make a specific type of measurement, trigger that measurement, then read the result and send the reading back to the controller, or to another device on the interface.

1-27. OPTIONS

1-28. Option 001 is a Temperature Compensated Crystal Oscillator (TCXO) for HP 5384A. The TCXO is a 10 MHz oscillator, capable of making minor frequency corrections to compensate for temperature variations.

1-29. Option 003 is HP-IL, (Hewlett-Packard Interface Loop). HP-IL is a low cost, two-wire serial interface that permits communications from one device to another. As the name implies, the HP 5384A or HP 5385A is connected in a serial loop structure. Data or information, in the form of digital messages, travels from one device to the next in the loop. If the information is not intended for the counter, the counter merely passes the information on to the next device in the loop. If the information is intended for the counter, the counter responds as directed by the information.

1-30. Option 004 is an ovenized oscillator that gives the HP 5384A and HP 5385A increased accuracy by providing a more stable time base reference signal. The oven maintains the crystal at a constant elevated temperature for increased stability over the ambient temperature range.

1-31. Option 005 Battery Pack is a lead acid type battery that provides at least 3 hours of operation while the counter is disconnected from the power line. Operation time is reduced to approximately 1-hour when operated with HP-IB.

NOTE

If an instrument contains an Option 005 Battery Pack as well as the ovenized oscillator, the ovenized oscillator will draw power from the battery pack if no external ac or dc power is applied. Power will be drawn from the battery pack continuously with the instrument in either ON or STBY (standby) positions.

1-32. The battery pack will be recharged in 16 hours if the counter is in the standby mode and either the line cord is attached or external dc is applied through the rear panel jack. The battery will trickle charge while the counter is being used and is connected to either an ac power line or external dc.

1-33. INSTRUMENT IDENTIFICATION

1-34. Hewlett-Packard instruments have a 2-section, 10-character serial number (0000A00000), which is located on the rear panel. The four-digit serial prefix identifies the instrument changes. If the serial prefix of your instrument differs from that listed on the title page of this manual, there are differences between this manual and your instrument. Instruments having higher serial prefixes are covered with a "Manual Changes" sheet included with this manual. If the change sheet is missing, contact the nearest Hewlett-Packard Sales and Support Office listed at the back of this manual. Instruments having a lower serial prefix than that listed on the title page are covered in Section VII.

1-35. ACCESSORIES

1-36. The accessory supplied is a detachable power cord 229 cm long (7½ feet), part number 8120-1378.

1-37. Side Handle: 5061-1171

1-38. Rack Mount Kits:

Rack Mount Kit, HP Part Number 5060-0173.
Locking Rack Mount Kit for two HP 5384A/
HP 5385A modules, HP Part Number 5060-0174.

1-39. RECOMMENDED TEST EQUIPMENT

1-40. The test equipment listed in *Table 1-2* is recommended for use during performance tests, adjustments, and troubleshooting. Substitute test equipment may be used if it meets the required characteristics listed in the table.

Table 1-1. Models HP 5384A and HP 5385A Specifications

GENERAL

Check: 10 MHz Self-test
Gate Times: 0.1, 1, or 10 seconds, (NOMINAL).
Display: 12-digit alphanumeric liquid crystal.
Display Digits (variable): Frequency, 3 to 11;
 Period, 3 to 8.
Timebase Output: 10 MHz, 25 mV pk-pk (NOMINAL)
 into 50 ohm load.
External Timebase Input: 10 MHz, .5V rms into
 500 ohms; 15V (dc - ac pk) max.
Operating Temperature: 0° to 50°C
Power Requirements:
AC Operation: Selectable 18 VA max.
 115V + 10%, -25%, 48-66 Hz
 230V + 10%, -15% 48-66 Hz
 115V ±10%, 380-420 Hz
DC Operation: 9 - 15V dc, 1.0 A max.
Weight: Net, 2.2 kg (4.8 lbs.); Shipping, 4.1 kg (9 lbs.)
Dimensions: 216 mm W × 88 mm H × 276 mm D
 (8½ × 3½ × 10¾ in.)

INPUT CHARACTERISTICS (Channel A HP 5384A/HP 5385A)

Range: 10 Hz to 100 MHz
Sensitivity: (MAN LEVEL) off
 15 mV rms sine wave 50 Hz to 100 MHz
 25 mV rms sine wave 10 Hz to 50 Hz
 45 mV pk-pk 5 ns minimum pulse width
Dynamic Range: 45 mV to 4V pk-pk × attenuator
 setting.
Coupling: AC
Impedance:
 X1: 1 MΩ NOMINAL || < 25 pF
 X20: 500 kΩ NOMINAL || < 25 pF
Attenuator: X1 or X20 NOMINAL,
 X20 increases to X40 NOMINAL below 50 Hz.
Low Pass Filter: 100 kHz NOMINAL 3 dB point
Trigger Level:
(MAN LEVEL) ON: variable from -0.1V to +0.1V ×
 attenuator setting about average signal value.
(MAN LEVEL) OFF: automatically set to average
 value of signal.

⚠ Damage Level:

X1:
 10 - 200 Hz 350V (dc + ac peak)
 0.2 - 420 kHz 170V (dc + ac peak)
 0.42 - 10 MHz (5 × 10⁷V rms Hz)/FREQ
 >10 MHz 5V rms
X20:
 <1 MHz, Same as X1
 >1 MHz, 50V rms

(Channel B HP 5384A)

Range: 50 to 225 MHz
Sensitivity: 10 mV rms 50 to 200 MHz
 15 mV rms 200 to 225 MHz
Dynamic Range: 10 mV to 1V rms
Coupling: AC
Impedance: 50 ohm NOMINAL
Attenuator Level:
Manual: variable from X1 to X5
 (0 to 14 dB) NOMINAL.
Auto: AGC mode for improved noise
 suppression.
Damage Level: 350V dc + 5V rms ac

(Channel B HP 5385A)

Fuse protected. Front panel accessible.
Range: 90 to 1000 MHz
Sensitivity: 15 mV rms sine wave 90-100 MHz
 10 mV rms sine wave 100-1000 MHz
Dynamic Range: 10 mV to 7V rms (-27 to +30 dBm)
Coupling: AC
Impedance: 50 ohm NOMINAL
Attenuator Level:
Manual: variable from X1 to X18
 (0 to 25 dB) NOMINAL.
Auto: AGC mode for improved noise suppression.
Damage Level:
 AC >1 MHz +30 dBm (7V rms)
 AC <1 MHz 2V rms
 DC ±5V

⚠ TIMEBASE HP 5384A

Frequency: 10 MHz
Aging Rate: <3 × 10⁻⁷/mo.
Temperature: ±5 × 10⁻⁶, 0° to 50°C.ref. to 25°C.
Line Voltage: <1 × 10⁻⁷ for ±10% variation.

⚠ TIMEBASE HP 5385A (TCXO)

Frequency: 10 MHz
Aging Rate: <1 × 10⁻⁷/mo.
Temperature: ±1 × 10⁻⁶, 0° to 40°C.ref. to 25°C.
Line Voltage: <5 × 10⁻⁸ for ±10% variation.

FREQUENCY A and B

Range Channel A: 10 Hz - 100 MHz

Range Channel B:

5384A: 50 MHz - 225 MHz

5385A: 90 MHz - 1.0 GHz

LSD Displayed: 10 Hz to 1 nHz

LSD $\frac{4 \text{ ns}}{\text{Gate Time}} \times \text{FREQ}$

Resolution: ±1 LSD

$\pm \frac{(1.4 \times \text{Trigger Error} + 1 \text{ ns rms})}{\text{Gate Time}} \times \text{Freq}$

Accuracy: ± Resolution ± Time Base
 Error × Frequency

Table 1-1. Models HP 5384A and HP 5385A Specifications (Continued)

PERIOD A

Range: 10 ns to 0.1 s

LSD Displayed: .001 fs to 10 ns

LSD: $\frac{4 \text{ ns}}{\text{Gate Time}} \times \text{period}$

Resolution: $\pm \text{LSD}$

$\pm \frac{(1.4 \times \text{Trigger Error} + 1 \text{ ns rms})}{\text{Gate Time}} \times \text{Per}$

Accuracy: $\pm \text{Resolution} \pm \text{Time Base Error} \times \text{Period}$

OPTIONS

Option 001 (HP 5384A), TXCO Timebase

Frequency: 10 MHz

Aging Rate: $< 1 \times 10^{-7}/\text{mo.}$

Temperature: $\pm 1 \times 10^{-6}$, 0° to 40°C ref. to 25°C.

Line Voltage: $< 5 \times 10^{-8}$ for $\pm 10\%$ variation.

Option 003, HP-IL

All HP-IL programmable functions, controls, and operations are the same as those for HP-IB except for interface functions Auto Address and Parallel Poll, which are also included.

R, AH, SH1, D, L1, (T1-5), C0, DC2, DT1, PP1, SR2, AA1, RL2, PD0, DD1.

Option 004, Oven Timebase

Frequency: 10 MHz

Aging Rate: $< 3 \times 10^{-8}/\text{mo. (2)}$

Temperature: $\pm 1 \times 10^{-7}$, 0° to 50°C ref. to 25°C.

Line Voltage: $< 2 \times 10^{-9}$ for a $\pm 10\%$ variation.

Battery Operation: The instrument operates for 3 hours (typical) with option 004.

Option 005, Battery

Type: Sealed Lead-acid; not covered under instrument warranty.

Capacity: Typically 4 hours of operation at 25°C (1).

Recharge Time: Typically 16 hours to 98% of full charge in instrument STBY (Standby) mode.

Battery Low Annunciator: Enabled 20 minutes prior to instrument shutdown nominally.

Line Failure Protection: Instrument automatically switches to battery in case of line failure.

Weight: Option 005 adds 1.4 kg. (3 lbs.) to weight of instrument. (1) without Option 004 installed. HP-IL replaces HP-IB when Option 005 is ordered from the factory.

HP-IB I/O Interface

Programmable Functions: Frequency A, Frequency B, Period A.

Programmable Controls: X20 Attn A, FILTER A, MAN LEVEL A/B, Gate Time.

Display: Normal, Increment, Decrement, Remote, Local

Miscellaneous Functions and Operating Commands: Diagnostics, 10 MHz Check, reset, initialize, Wait To Send ON/OFF Device ID.

Interface Functions: Device Clear, Group Execute Trigger Interface Clear, Local, Local Lockout, Send Status, Remote, Service Request.

SH1, AH1, T5, TE0, L4, LE0, SR1, RL1, PP0, DC1, DT1, C0, E1.

Data Output:

Output will be maximum resolution for the gate time selected and is not affected by the front panel Display Digits keys.

Format: 17 characters plus CR and LF (blanks may be inserted).

Rate: 4 readings/s maximum at .1 s gate.

Talk only: Set with address switch=31.

DEFINITIONS

Measurement Gate Time: Selected value $\pm 15\%$ + up to 1 period of input.

Dynamic Range: Minimum to maximum input voltage swing allowed for correct frequency counting.

LSD Displayed: Dependent on gate time, input signal, and DISPLAY DIGITS control. In NORM mode, 8 digits are displayed. Using the display control, up to 11 digits may be present for frequency measurements, 8 digits maximum for period.

LSD: Unit value of least significant digit rounded to the nearest decade, i.e., 4 Hz \rightarrow 1 Hz, 6 Hz \rightarrow 10 Hz.

Trigger Error:

Channel A:

$\frac{\sqrt{(e_i)^2 + (e_n)^2}}{\text{Input slew rate at trigger point}}$ s rms,

where e_i and e_n are input noise voltages (rms) for the counter and signal, respectively, for a 100 MHz bandwidth.

$e_i \leq 100 \mu\text{V rms}$,

Channel B: negligible due to high signal slew rate at the trigger point.

Best Case Resolution for 1 second gate (\pm Hz)

Amplitude mV rms	Frequency (Hz)									
	10	100	1K	10K	100K	1M	10M	100M	200M	1.0G
50	.0003	.0003	.0003	.0003	.0008	.004	.04	0.4	0.8	4.0
100	.0002	.0002	.0002	.0003	.0007	.004	.04	0.4	0.8	4.0
500	.0002	.0002	.0002	.0003	.0006	.004	.04	0.4	0.8	4.0
1000	.0001	.0001	.0001	.0001	.0005	.004	.04	0.4	0.8	4.0

This chart shows best case frequency resolution vs sine wave input voltage (rms). Noise from the signal source is assumed to be zero and trigger error produced only by the counter's noise (i.e., 100 $\mu\text{V rms}$).

LSD DISPLAYED: Unit value of least significant digit rounded to the nearest decade, i.e., 4 Hz \rightarrow 1 Hz, 6 Hz \rightarrow 10 Hz.

Table 1-2. Recommended Test Equipment

Instrument	Critical specifications	Recommended Model	Use
50 Ohm Feedthrough	BNC Type	HP 10100C	P,A,T
Tee Connector	BNC Type	HP 1250-0781	P,A,T
Cables	BNC 50 ohm	HP 11170C	P,A,T
Oscilloscope	100 MHz Bandwidth	HP 1740A	A,T
Synthesized Generator	90-1000 MHz	HP 8660C/86602A	P,T
Signal Generator	50-225 MHz	HP 8656A	P,A,T,
Signal Generator	90-1000 MHz	HP 804A	P,T
Synthesized Function Generator	10 Hz to 20 MHz	HP 3325A	P,A,T
DC Voltmeter	20V Range, 0.05V resolution	HP 3465	A,T
Power Splitter	90 MHz-1 GHz Cal. output	HP 11667A	A,T
Power Meter/Sensor	90 MHz-1 GHz, -9 to -24 dBm	HP 436A/8481A	P
10 dB Attenuator		HP 8491A	P
Adapter, Coaxial (2 required)	Type N(male)-to-BNC(female)	1250-07680	P
Adapter, Coaxial	Type N(male)-to-BNC(male)	1250-0082	P
Controller	HP-IB Compatible	HP-85F*	
Controller	HP-IL Compatible	HP-41CV	P
Interface	HP-IL Compatible	HP 82938A	
Resistor	10Ω 20W	0811-1655	A

*HP-85F consists of the following:

Controller	HP-85A
I/O ROM	00085-15003
ROM Drawer	HP 82936A
HP-IB Interface Card/Cable	HP 82937A

SECTION II INSTALLATION

2-1. INTRODUCTION

2-2. This section contains information for unpacking, inspection, storage, and installation.

2-3. UNPACKING AND INSPECTION

2-4. If the shipping carton is damaged, inspect the instrument for visible damage (scratches, dents, etc.). If the instrument is damaged, notify the carrier and the nearest Hewlett-Packard Sales and Service Office immediately (offices are listed at the back of this manual). Keep the shipping and packing material for the carrier's inspection. The Hewlett-Packard Sales and Service Office will arrange for repair or replacement of your instrument without waiting for the claim against the carrier to be settled.

2-5. PREPARATION FOR USE

CAUTION

Before connecting the instrument to ac power lines, be sure that the voltage selector is properly positioned as described below.

2-6. POWER REQUIREMENTS

2-7. The counter has the following ac power requirements:

- 115V, +10%, -25%, 48-66 Hz single phase
- 230V, +10%, -15%, 48-66 Hz single phase
- 115V, +10%, -10%, 380-420 Hz single phase

2-8. LINE VOLTAGE SELECTION

2-9. The power line voltage is selected by the position of the LINE SELECT switch on the rear panel. Sliding the switch to the left selects 115V operation, sliding the switch to the right selects 230V operation. The voltages available are printed on the switch. The specific voltage selected will be visible on the LINE SELECT switch, as shown in Figure 2-1. Before applying power, verify that the LINE SELECT switch is properly set for the desired ac supply voltage and that the correct fuse is installed.

2-10. AC Line Fuse Selection

2-11. The ac line fuse is not accessible from the outside of the cabinet. The cabinet should be opened

only by qualified service personnel. The correct fuse value is 250 mA/250V Slow Blow for 115V or 230V operation.

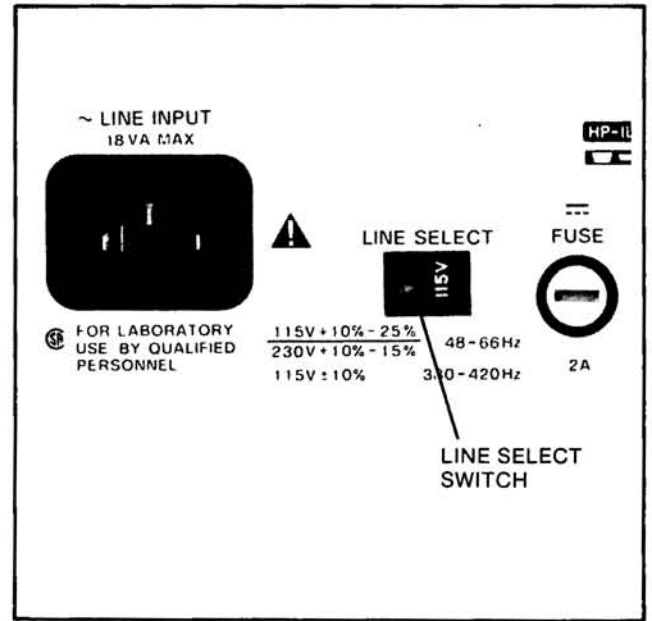

Figure 2-1. Line Voltage Selection

2-12. DC Fuse Selection

2-13. To replace the dc fuse use a small flat-bladed screwdriver to remove the fuse from the fuseholder. Press in slightly and turn counterclockwise, until the fuse carrier springs free. Replace the fuse in the fuse carrier and reinstall by inserting and turning clockwise. Be sure to install the correct fuse value; 2 A/250V fast blow.

2-14. The dc fuse is the main protective device for the instrument. The dc fuse will blow whether the dc current source is the optional battery pack, power from the external dc power jack, or the built-in ac power supply.

2-15. Power Cable

2-16. The counter is shipped with a three-wire power cable. When the cable is connected to an appropriate ac power source, this cable connects the instrument chassis to earth ground. The type of power cable plug shipped with each instrument depends on the country

of destination. Refer to *Figure 2-2* for the part numbers of the power cable and plug configurations available.

WARNING

BEFORE ENERGIZING THIS INSTRUMENT, THE PROTECTIVE EARTH TERMINAL OF THIS INSTRUMENT MUST BE CONNECTED TO THE PROTECTIVE CONDUCTOR OF THE (MAINS) POWER CORD. THE MAINS PLUG SHALL ONLY BE INSERTED IN A SOCKET OUTLET PROVIDED WITH A PROTECTIVE EARTH CONTACT. THE PROTECTIVE ACTION MUST NOT BE NEGATED BY THE USE OF AN EXTENSION CORD (POWER CABLE) WITHOUT A PROTECTIVE EARTH (GROUNDING) CON-DUCTOR.

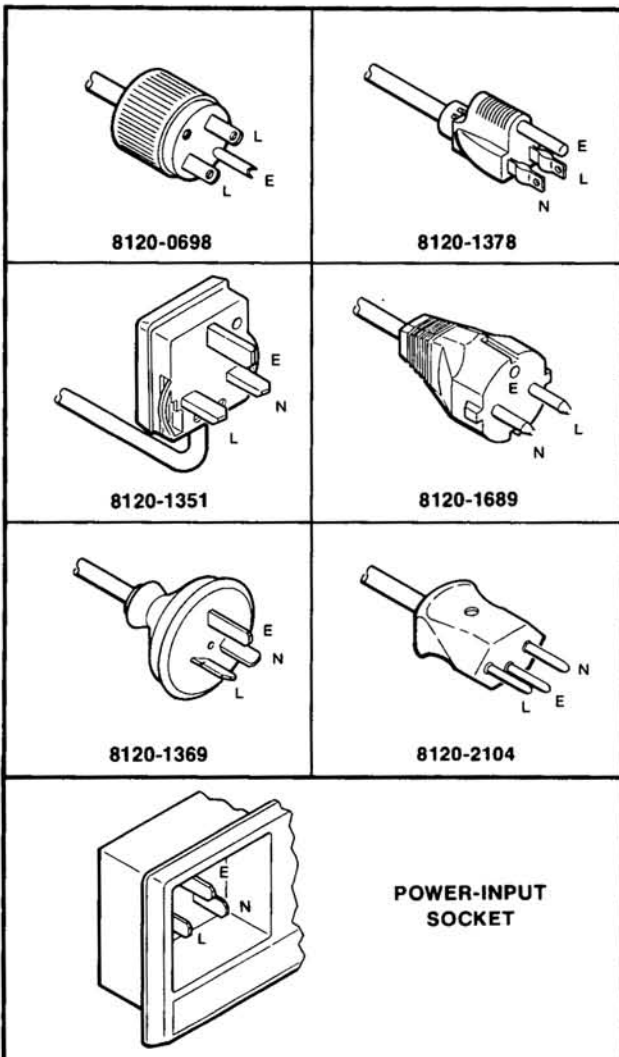

Figure 2-2. Power Cable HP Part Number versus Mains Plugs Available

2-17. HP-IB Interconnections

2-18. HEWLETT-PACKARD INTERFACE BUS. The counter with HP-IB is compatible with the Hewlett-Packard Interface Bus. Interconnection data concerning the rear panel HP-IB connector is provided in *Figure 2-3*. This connector is compatible with the HP 10833A/B/C/D cables. (See *Table 2-1* for cable descriptions). The HP-IB system allows interconnection of up to 15 (including the controller) HP-IB compatible instruments.

Table 2-1. HP-IB Cable Descriptions

HP Model	Cable Length
10833A	1 metre (3.3 feet)
10833B	2 metres (6.6 feet)
10833C	4 metres (13.2 feet)
10833D	0.5 metres (1.6 feet)

2-19. The HP-IB cables have identical "piggy-back" connectors on both ends so that several cables can be connected to a single source without special adapters or switch boxes. System components and devices may be connected in virtually any configuration desired. There must, of course, be a path from the calculator (or other controller) to every device operating on the bus. As a practical matter, avoid stacking more than three or four cables on any one connector. If the stack gets too large, the force on the stack produces great leverage which can damage the connector mounting. Be sure each connector is firmly (finger tight) screwed in place to keep it from working loose during use.

2-20. CABLE LENGTH RESTRICTIONS. To achieve design performance with the HP-IB, the proper voltage levels and timing relationships must be maintained. If the system cable is too long, the lines cannot be driven properly, and the system will fail to perform properly. Therefore, when interconnecting an HP-IB system, it is important to observe the following rules.

- The total cable length for the system must be less than or equal to 20 metres (65.6 feet).
- The total cable length for the system must be less than or equal to 2 metres (6.6 feet) times the total number of devices connected to the bus.
- The total number of instruments connected to the bus must not exceed 15.

2-21. HP-IB Talk/Listen Address Switch

2-22. The HP 5384A and HP 5385A provide a rear panel HP-IB instrument address selection switch. This switch determines the mode of remote operation as

PIN	LINE
1	DIO1
2	DIO2
3	DIO3
4	DIO4
13	DIO5
14	DIO6
15	DIO7
16	DIO8
5	EOI
17	REN
6	DAV
7	NRFD
8	NDAC
9	IFC
10	SRQ
11	ATN
12	SHIELD-CHASSIS GROUND
18	P/O TWISTED PAIR WITH PIN 6
19	P/O TWISTED PAIR WITH PIN 7
20	P/O TWISTED PAIR WITH PIN 8
21	P/O TWISTED PAIR WITH PIN 9
22	P/O TWISTED PAIR WITH PIN 10
23	P/O TWISTED PAIR WITH PIN 11
24	ISOLATED DIGITAL GROUND

THESE PINS ARE INTERNALLY GROUNDED

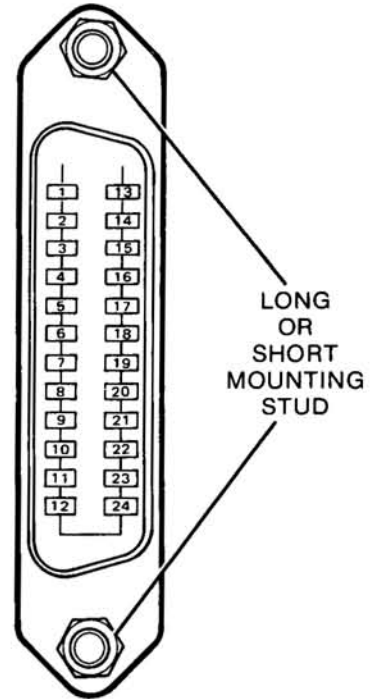

CAUTION

The HP 5384A/HP 5385A contains metric threaded HP-IB cable mounting studs as opposed to English threads. Metric threaded HP 10833A, B, C, or D HP-IB cable lock screws must be used to secure the cable to the instrument. Identification of the two types of mounting studs and lock screws is made by their color. English threaded fasteners are colored silver and metric threaded fasteners are colored black. DO NOT mate silver and black fasteners to each other or the threads of either or both will be destroyed. Metric threaded HP-IB cable lock screw illustration and part number follows.

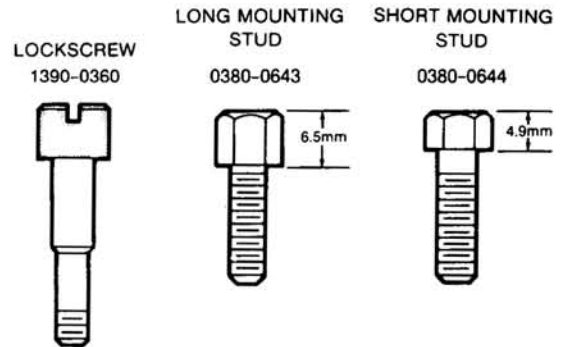

Logic Levels

The Hewlett-Packard Interface Bus logic levels are TTL compatible, i.e., the true (1) state is 0.0V dc to 0.4V dc and the false (0) state is +2.5V dc to +5.0V dc.

Programming and Output Data Format

Refer to Section III, Operation

Mating Connector

HP 1251-0293; Amphenol 57-30240.

Mating Cables Available

HP 10833A, 1 metre (3.3 ft.), HP 10833B, 2 metres (6.6 ft.), HP 10833C, 4 metres (13.2 ft.), HP 10833D, 1/2 metre (1.6 ft.).

Cabling Restrictions

1. A Hewlett-Packard Interface Bus System may contain no more than 2 metres (6.6 ft.) of connecting cable per instrument.
2. The maximum accumulative length of connecting cable for any Hewlett-Packard Interface Bus System is 20.0 metres (65.6 ft.).
3. The maximum number of instruments in one system is fifteen.

Figure 2-3. Hewlett-Packard Interface Bus Connections



HP 5384A and HP 5385A
Installation

“Talk Only” or “addressable”, and selects the HP-IB address. Instructions for changing the address are provided in Section III of this manual.

2-23. HP-IB Description

2-24. A description of the HP-IB is provided in Section III of this manual. A study of this information is necessary if the user is not familiar with the HP-IB concept. Additional information concerning the design criteria and operation of the bus is available in IEEE Standard 488-1978, titled “*IEEE Standard Digital Interface for Programmable Instrumentation*”.



The above symbol when located in the upper corner of a page indicates HP-IB information is contained on that page. This information may be operation, performance, adjustments, or service related.

2-25. HP-IL Interconnections (Option 003)

2-26. The HP 5384A and HP 5385A with Option 003 are compatible with the Hewlett-Packard Interface Loop. The interface loop connection is made by a pair of two-wire balanced line cables. The cable is limited to 10 metres (32.8 feet) for unshielded cables (from one device to the next) and to 100 metres (328 feet) for shielded cables. A typical interface connection is shown in Figure 2-4.

Table 2-2. HP-IL Cable Descriptions

HP Model	Length
82167A	.5 metres (1.64 feet)
82167B	1 metre (3.28 feet)
82167D	10 metres (32.8 feet)

2-27. HP-IL Description

2-28. An introductory description on HP-IL is provided in Section III of this manual. As HP-IL is a relatively new concept, it is recommended that users unfamiliar with the Interface Loop concept review this material prior to operating the instrument remotely.



The above symbol when located in the upper corner of a page indicates HP-IL information is contained on that page. This information may be operation, performance, adjustment, or service related.

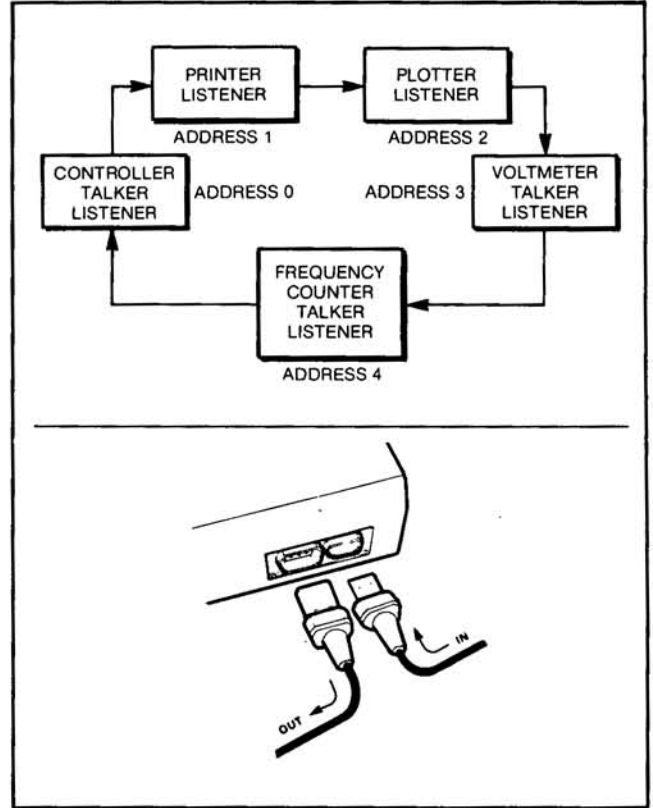

Figure 2-4. Typical HP-IL Interface Connection

2-29. Channel B Input Fuse

2-30. Figure 2-5 shows the details of how to change the fuse in the channel B input of the HP 5385A.

2-31. Operating Environment

2-32. TEMPERATURE. The counter may be operated in temperatures from 0°C to +50°C.

2-33. HUMIDITY. The counter may typically be operated in environments with humidity up to 95% at 40°C. However, it should be protected from extreme temperatures which may cause condensation in the instrument.

2-34. ALTITUDE. The counter may be typically operated at altitudes up to 4,600 metres (15,000 feet).

2-35. STORAGE AND SHIPMENT

2-36. Environment

2-37. The instrument may be stored or shipped in environments within the following limits:

- TEMPERATURE -40°C to +75°C
- HUMIDITY ... Up to 95% noncondensing
- ALTITUDE 15,240 Metres (50,000 feet)

2-38. The instrument should also be protected from temperature and humidity extremes which cause condensation within the instrument.

2-39. Packaging

2-40. ORIGINAL PACKAGING. Containers and materials identical to those used in the factory packaging are available through Hewlett-Packard offices. If the instrument is being returned to Hewlett-Packard for servicing, attach a tag indicating the type of service required, return address, model number, and full serial number. Also, mark the container FRAGILE to ensure careful handling. In any correspondence, refer to the instrument by model number and full serial number.

2-41. OTHER PACKAGING. The following general instructions should be used for repacking with commercially available materials.

a. Wrap the instrument in heavy paper or plastic. If you are shipping to a Hewlett-Packard office or

service center, attach a tag indicating the type of service required, return address, model number, and full serial number.

b. Use a strong shipping container. A double-wall carton made of 350-pound test material is adequate.

c. Use a layer of shock-absorbing material 70 to 100 mm (3- to 4-inch) thick around all sides of the instrument to provide firm cushioning and prevent movement inside the container. Protect the control panel with cardboard.

d. Seal the shipping container securely.

e. Mark the shipping container FRAGILE to ensure careful handling.

f. In any correspondence, refer to the instrument by model number and full serial number.

2-42. WHERE TO SHIP YOUR UNIT FOR REPAIR

2-43. Return your unit to the nearest designated Hewlett-Packard Sales and Support Office. Check the back of this manual for the address.

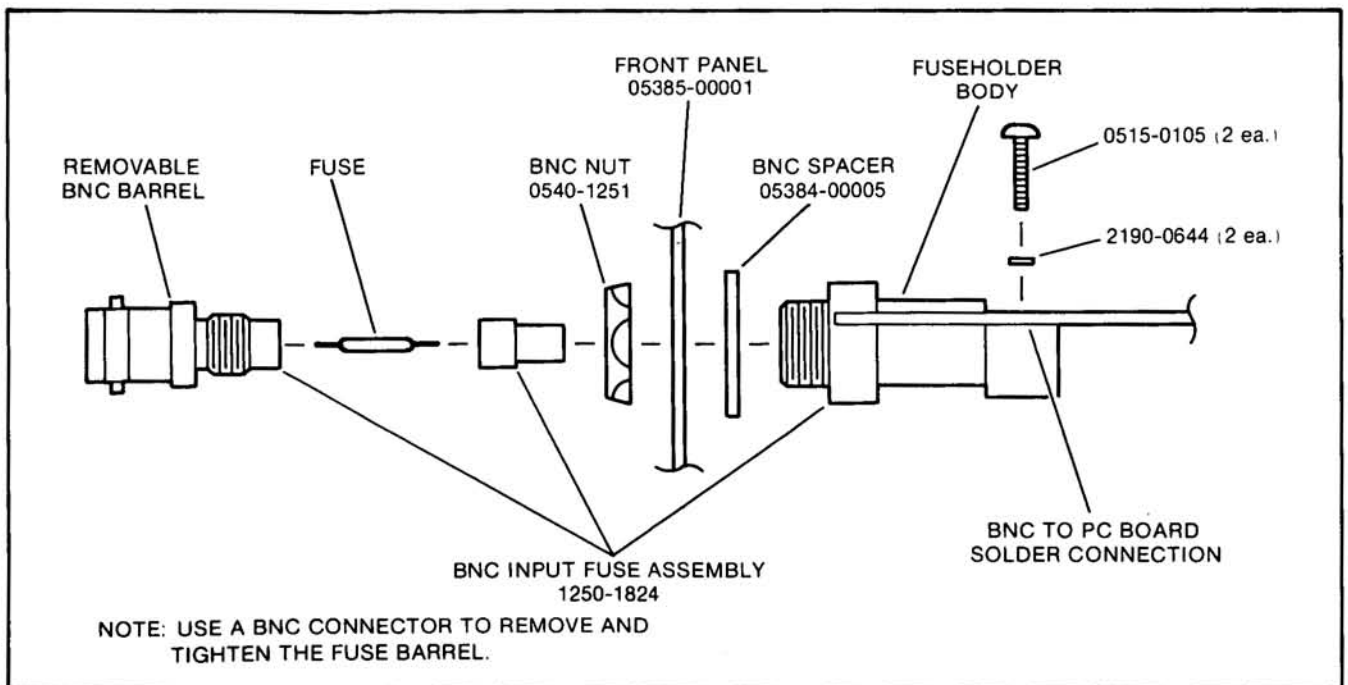

Figure 2-5. Details of Input Connector J2 and Fuse Mounting



2-44. FIELD INSTALLATION OF OPTIONS

2-45. The following information provides instructions for installation of the various options for the HP 5384A and HP 5385A.

2-46. Refer to *Table 2-3* for a list of the parts required for installation of each option.

Table 2-3. Required Parts for Field Installed Options

Opt.	Ref. Des.	Description	Pt. No.
001	Y1B R101 C67	10.0 MHz TCXO 422 ohm, 1%, .125W .01 μ F, \pm 20%, 100 Vdc	0960-0612 0698-3447 0160-3879
003	A4	HP-IL Assembly	05006-60004
004	T1A R95 L5	10 MHz Oven Oscillator Module 100 ohm, 1%, .125W Inductor, Wide-band, $Z_{max} = 680$ ohm @ 180 MHz	0960-0636 0757-0401 9100-1788
005		Battery Pack Assembly Heat Sink Compound	05384-60103 8500-0269

WARNING

TO PREVENT ELECTRICAL SHOCK, REMOVE ALL POWER FROM THE COUNTER BEFORE REMOVING THE TOP COVER.

2-47. To obtain the necessary parts for installation of an option, order by part number as listed in *Table 2-3*. Refer to Section VI for further ordering information.

2-48. Option 001 (TCXO) Installation

2-49. The Option 001 TCXO replaces the standard reference oscillator in the HP 5384A. The standard oscillator is located on the A1 motherboard underneath the interface board. The standard oscillator components must first be removed before the TCXO can be installed. Proceed as follows.

- a. Remove the ac power cord.
- b. Remove the vinyl strips on each side of the counter by peeling them off.
- c. Remove the four pozidriv screws located at the bottom of the counter. The rear feet must be removed to access the two rear screws. Removal instructions are molded into each foot.
- d. Lift off the top cover from the counter.
- e. Remove the metal rack mount brackets.
- f. Remove the four black spacer tubes.
- g. Remove the two pozidriv screws securing the A1 motherboard to the bottom cover.
- h. Remove the bottom cover.
- i. Remove the interface board.
- j. Remove the standard oscillator by removing the following components:
C61-C66, R96-R99, R110, Q13, Q14, Y1C.
- k. Install the TCXO by soldering the following components in place:
C67, R101, Option 001 TCXO (Y1B).
- l. Install the interface board.
- m. Install top and bottom covers by following steps "a" through "h" in reverse order.
- n. Refer to Section V for the TCXO adjustment procedure.

2-50. Option 003 HP-IL Installation

2-51. The Option 003 HP-IL replaces HP-IB. To install the Option 003, proceed as follows:

- a. Remove the ac power cord.
- b. Remove the vinyl strips on each side of the counter by peeling them off.
- c. Remove the four pozidriv screws located at the bottom of the counter. The rear feet must be removed to access the two rear screws. Removal instructions are molded into each foot.
- d. Lift off the top cover from the counter.
- e. Remove the metal rack mount brackets.
- f. Remove the four black spacer tubes.
- g. Remove the two pozidriv screws securing the A1 motherboard to the bottom cover.
- h. Remove the bottom cover.
- i. Remove the HP-IB board.
- j. Insert the 28 pin IC (U1) in its socket on the HP-IL board.
- k. Insert the 40 pin IC (U2-1) in its socket on the HP-IL board.
- l. Insert the 24 pin IC (U2-2) in its socket on top of U2-1.
- m. Place the board on the plastic standoff support and secure the bracket to the rear panel of the counter with the two screws provided.

- n. Insert the flat ribbon cable connector into J8 on the motherboard.
- o. Install top and bottom covers by following steps "a" through "h" in reverse order.

2-52. Option 004 Oven Oscillator Installation

2-53. The Option 004 Oven Oscillator replaces the standard reference oscillator in the 5384A or the TCXO in the 5385A. To install the Option 004 proceed as follows:

- a. Remove the ac power cord.
- b. Remove the vinyl strips on each side of the counter by peeling them off.
- c. Remove the four posidriv screws located at the bottom of the counter. The rear feet must be removed to access the two rear screws. Removal instructions are molded into each foot.
- d. Lift off the top cover from the counter.
- e. Remove the metal rack mount brackets.
- f. Remove the four black spacer tubes.
- g. Remove the two posidriv screws securing the A1 motherboard to the bottom cover.
- h. Remove the bottom cover.
- i. Remove the interface board.
- j. If the counter is an HP 5384A with a standard oscillator, remove the standard oscillator by removing the following components:
 - C61-C66, R96-R99, R110, Q13, Q14, Y1C, jumper W2.
- k. If the counter is an HP 5384A or HP 5385A with a TCXO, remove Y1B, R95, and jumper W2.
- l. Install Y1A, the 100 ohm resistor in the R95 position and the inductor in the L5 position.
- m. Reassemble the counter by following steps "a" through "i" in reverse order.
- n. Refer to Section V for the oscillator adjustment procedure.

2-54. Option 005 Battery Pack Installation

2-55. The following instructions describe how to attach the battery pack assembly to the inside of the counter's top cover. The battery pack is attached far enough forward to clear the power transformer and interface board when the cover is replaced. To install the battery pack:

- a. Remove the top cover and place it upside-down on a sturdy level surface, with the front of the cover toward you.
- b. Place a plastic washer on each of the five unpainted studs ($\frac{5}{16}$ " high \times $\frac{3}{8}$ " dia.) on the inside of the top cover. (A sixth stud at the rear of the cover is painted flat black and remains unused.)
- c. Lay the battery frame on top of the five plastic washers. The battery frame is the aluminum sheet-metal plate that has five holes and a "+" and "-" symbol punched into it.

NOTE

There are also two tabs formed in it to position the battery. Insure the battery frame is mounted with the "+" and "-" symbol toward the front of the cover.

- d. Secure the battery frame to the top cover by installing push-on retainer rings onto the five studs. Use as pushing tool any nonscratching rigid tubing that will fit over the studs.
- e. Set the battery on the battery frame between the two upright tabs so the "+" and "-" battery terminals match the "+" and "-" symbols punched into the battery frame.
- f. Secure the battery by first aligning the "+" and "-" terminals on the battery with the "+ POS" and "- NEG" labels on the battery stop; then place the battery stop over the battery. Secure the battery stop with four screws and four lock washers.

NOTE

The battery stop can be identified by locating a $3\frac{1}{2} \times 5\frac{1}{2}$ inch aluminum sheetmetal box-like form that partially encloses the battery. There are several cautions printed on it. The battery stop also provides a mounting surface for the battery charger board.

- g. Thread the red lead from the bottom of the A3 board through the larger of two holes in the corner near A3F1 (the "+" location). Insert the lead in the smaller hole (in the trace) and pull the excess wire back through the hole. Solder the lead then clip off excess lead length.
- h. Install the black lead at the "-" location near A3J1 in the same manner as the red lead (step "g").
- i. Mount the battery charger board by inserting two tabs on the PC board into the two slots in the battery stop. The slots are located in the rear facing side of the battery stop. Temporarily secure the board with one screw.

HP 5384A and HP 5385A
Installation

- j. Place the transistor in the Q2 location so the hole in the transistor heat sink aligns with the threaded hole in the battery stop. Trim the leads on the transistor to provide clearance between the A3 board and the battery stop.
- k. Secure the heat sink temporarily to the battery stop with a screw.
- l. Solder one lead of the transistor to the A3 board.
- m. Remove the A3 board and solder the remaining two leads. Clip the soldered leads to avoid shorting against the battery stop.
- n. Spread heat sink compound on the back of the transistor. Enough compound should be applied so that when the transistor is secured to the battery stop (step "p") a tiny amount will ooze from underneath the transistor. Good thermal conduction will result.
- o. Place the transistor insulator underneath transistor Q2: The tab fits into a slot at the edge of the A3 board. Align The hole in the insulator with the hole in the heat sink.
- p. Place the insulator washer on the heat sink, secure Q2 to the battery stop with a screw.
- q. Secure the A3 board to the battery stop with two screws and two lock washers.
- r. Attach the rubber bumper to the battery stop in the square silk screened on the battery stop.
- s. Connect the ribbon cable W2 to A3J1 and A1J9.
- t. Test and adjust the battery charger board. Refer to Section V, paragraph 5-26, for adjustment procedures.
- u. Replace the cover on the counter, installation is complete.



**HEWLETT
PACKARD**

Should one of your HP instruments need repair, the HP service organization is ready to serve you. However, you can help us serve you more effectively. When sending an instrument to HP for repair, please fill out this card and attach it to the product. Increased repair efficiency and reduced turn-around time should result.

COMPANY _____

ADDRESS _____

TECHNICAL CONTACT PERSON _____

PHONE NO. EXT. _____

MODEL NO. SERIAL NO. _____

P.O. NO. DATE _____

Accessories returned with unit

- NONE CABLE(S)
 POWER CABLE ADAPTER(S)
 OTHER _____

(over)



**HEWLETT
PACKARD**

Should one of your HP instruments need repair, the HP service organization is ready to serve you. However, you can help us serve you more effectively. When sending an instrument to HP for repair, please fill out this card and attach it to the product. Increased repair efficiency and reduced turn-around time should result.

COMPANY _____

ADDRESS _____

TECHNICAL CONTACT PERSON _____

PHONE NO. EXT. _____

MODEL NO. SERIAL NO. _____

P.O. NO. DATE _____

Accessories returned with unit

- NONE CABLE(S)
 POWER CABLE ADAPTER(S)
 OTHER _____

(over)



**HEWLETT
PACKARD**

Should one of your HP instruments need repair, the HP service organization is ready to serve you. However, you can help us serve you more effectively. When sending an instrument to HP for repair, please fill out this card and attach it to the product. Increased repair efficiency and reduced turn-around time should result.

COMPANY _____

ADDRESS _____

TECHNICAL CONTACT PERSON _____

PHONE NO. EXT. _____

MODEL NO. SERIAL NO. _____

P.O. NO. DATE _____

Accessories returned with unit

- NONE CABLE(S)
 POWER CABLE ADAPTER(S)
 OTHER _____

(over)



**HEWLETT
PACKARD**

Should one of your HP instruments need repair, the HP service organization is ready to serve you. However, you can help us serve you more effectively. When sending an instrument to HP for repair, please fill out this card and attach it to the product. Increased repair efficiency and reduced turn-around time should result.

COMPANY _____

ADDRESS _____

TECHNICAL CONTACT PERSON _____

PHONE NO. EXT. _____

MODEL NO. SERIAL NO. _____

P.O. NO. DATE _____

Accessories returned with unit

- NONE CABLE(S)
 POWER CABLE ADAPTER(S)
 OTHER _____



**HEWLETT
PACKARD**

Should one of your HP instruments need repair, the HP service organization is ready to serve you. However, you can help us serve you more effectively. When sending an instrument to HP for repair, please fill out this card and attach it to the product. Increased repair efficiency and reduced turn-around time should result.

COMPANY _____

ADDRESS _____

TECHNICAL CONTACT PERSON _____

PHONE NO. EXT. _____

MODEL NO. SERIAL NO. _____

P.O. NO. DATE _____

Accessories returned with unit

- NONE CABLE(S)
 POWER CABLE ADAPTER(S)
 OTHER _____



**HEWLETT
PACKARD**

Should one of your HP instruments need repair, the HP service organization is ready to serve you. However, you can help us serve you more effectively. When sending an instrument to HP for repair, please fill out this card and attach it to the product. Increased repair efficiency and reduced turn-around time should result.

COMPANY _____

ADDRESS _____

TECHNICAL CONTACT PERSON _____

PHONE NO. EXT. _____

MODEL NO. SERIAL NO. _____

P.O. NO. DATE _____

Accessories returned with unit

- NONE CABLE(S)
 POWER CABLE ADAPTER(S)
 OTHER _____

Service needed

CALIBRATION ONLY REPAIR

OTHER _____

Observed symptoms/problems

FAILURE MODE IS:

CONSTANT INTERMITTENT

SENSITIVE TO:

COLD HEAT VIBRATION

FAILURE SYMPTOMS _____

If unit is part of automatic system list model numbers of controller and other related components. _____

9320-3896

Printed in U.S.A.

Service needed

CALIBRATION ONLY REPAIR

OTHER _____

Observed symptoms/problems

FAILURE MODE IS:

CONSTANT INTERMITTENT

SENSITIVE TO:

COLD HEAT VIBRATION

FAILURE SYMPTOMS _____

If unit is part of automatic system list model numbers of controller and other related components. _____

9320-3896

Printed in U.S.A.

Service needed

CALIBRATION ONLY REPAIR

OTHER _____

Observed symptoms/problems

FAILURE MODE IS:

CONSTANT INTERMITTENT

SENSITIVE TO:

COLD HEAT VIBRATION

FAILURE SYMPTOMS _____

If unit is part of automatic system list model numbers of controller and other related components. _____

9320-3896

Printed in U.S.A.

Service needed

CALIBRATION ONLY REPAIR

OTHER _____

Observed symptoms/problems

FAILURE MODE IS:

CONSTANT INTERMITTENT

SENSITIVE TO:

COLD HEAT VIBRATION

FAILURE SYMPTOMS _____

If unit is part of automatic system list model numbers of controller and other related components. _____

Service needed

CALIBRATION ONLY REPAIR

OTHER _____

Observed symptoms/problems

FAILURE MODE IS:

CONSTANT INTERMITTENT

SENSITIVE TO:

COLD HEAT VIBRATION

FAILURE SYMPTOMS _____

If unit is part of automatic system list model numbers of controller and other related components. _____

Service needed

CALIBRATION ONLY REPAIR

OTHER _____

Observed symptoms/problems

FAILURE MODE IS:

CONSTANT INTERMITTENT

SENSITIVE TO:

COLD HEAT VIBRATION

FAILURE SYMPTOMS _____

If unit is part of automatic system list model numbers of controller and other related components. _____

SECTION III OPERATION AND PROGRAMMING

3-1. INTRODUCTION

3-2. This section gives complete operation and programming information for the HP 5384A and HP 5385A Frequency Counters. Descriptions of all front panel controls, connectors, and indicators, as well as an operator's check, operating instructions, programming instructions and codes, and operator's maintenance, are provided. Unless otherwise specified, all information pertains to both counters.

3-3. OPERATING CHARACTERISTICS

3-4. The HP 5384A and HP 5385A can be configured for system or benchtop use. They make frequency and period measurements. Inputs enter through two channels. Raw data from the input measurements are used by the counter's microcomputer to compute and format the result either for display or transmission over the interface. The operating range, resolution and accuracy for each individual functional mode is given in the Specifications, *Table 1-1*.

3-5. Descriptions of and operating instructions for Options 001, 003, 004, 005 are provided in this section.

3-6. OPERATING INSTRUCTIONS

3-7. Information and instructions for operating the HP 5384A and HP 5385A in both local and remote modes are provided in this section. The following paragraphs summarize the organization and content of the operating information.

3-8. LOCAL OPERATION. The operating information for local (or manual) operation of the counter consists of the following topics:

General Operation Information. The General Operation Information describes the basic operation of the instrument display, the inputs, and the front panel keyboard.

Front and Rear Panel Features. The front and rear panel features consists of *Figures 3-7* through *3-9* which locate and describe all the operator controls and indicators.

Making Frequency and Period Measurements. Making Frequency and Period Measurements describes the recommended procedure for making a measurement.

3-9. REMOTE OPERATION. A good working knowledge of the local operation of the counter is essential for remote programming, as most of the data messages perform the same key-stroke-like sequences. The Remote Operation/Programming instructions describe the following:

- Interface Description
- Interface Functional Overview
- Interface System Overview
- Address Selection
- Interface Function
- Interface Commands
- Input Format
- Output Format
- Measurement Triggering in Remote SRQ, SRQ Mask, and Status Byte
- Device Dependent Commands
- Device Command Definitions
- Power-up and Default States
- Programming Examples

3-10. OPERATOR'S MAINTENANCE

3-11. The only maintenance the operator should normally perform is the replacement of the dc fuse. Refer to Section II, Line Voltage Selection, for instructions on changing the fuse.

3-12. The standard oscillator adjustment is also accessible from the rear panel. The oscillator is factory set at 10 MHz. Once adjusted, the oscillator should need little future attention except for periodic calibration using a precision frequency source. To adjust the standard oscillator, refer to Section V, Standard Oscillator Adjustment.

3-13. GENERAL OPERATION INFORMATION

3-14. Introduction

3-15. The following paragraphs describe the general operating features of the HP 5384A and HP 5385A Frequency Counters.

3-16. Display

3-17. All display functions are performed by a Liquid Crystal Display assembly. The assembly contains 12 alphanumeric characters; the display format for all measurements is in engineering notation. The left-

most character is CHARACTER 1 and the rightmost is CHARACTER 12. The scale or units designation will normally be shown in character positions 10, 11, and 12. If positions 10 and 11 are required to display a high resolution measurement, only character position 12 will be used to designate the scale or units.

3-18. Annunciation for all operating modes is also indicated by the display. When a mode is selected, an arrow appears at the bottom of the display just above the name of the mode label on the front panel.

3-19. Keyboard

3-20. The keyboard, located on the front panel, is a 14-position pushbutton assembly which is connected to a port on the microcomputer. The keyboard is divided into several groups, according to the purpose of the keys. From the left after the power switch, we have A, B, A&B, GATE, and DISPLAY DIGITS keys.

3-21. A blue RESET/LOCAL key and the CHECK key complete the keyboard assembly of the counter.

3-22. INPUTS

3-23. Immediately to the right of the keyboard is the INPUTS section. There are two BNC inputs (Channels A and B) and a control for either adjusting the trigger level of Channel A or attenuating the input signal to Channel B.

3-24. Power-Up/Self-Check

WARNING

BEFORE USING THE INSTRUMENT, ALL PROTECTIVE EARTH TERMINALS, EXTENSION CORDS, AUTOTRANSFORMERS AND DEVICES CONNECTED TO IT SHOULD BE CONNECTED TO A PROTECTIVE EARTH GROUNDED SOCKET. ANY INTERRUPTION OF THE PROTECTIVE EARTH GROUND WILL CAUSE A POTENTIAL SHOCK HAZARD THAT COULD RESULT IN PERSONAL INJURY.

CAUTION

Before energizing the counter, the instrument must be set to the voltage of the power source or damage to the instrument may result. See Section II.

3-25. When you power-up the counter, an internal check is automatically made of several major com-

ponents in its circuitry. During this cycle, all 12 Liquid Crystal Display (LCD) digits will be momentarily activated in a starburst pattern. Also activated are the colons and annunciators. The address of the interface will briefly be displayed.

3-26. After the power-up sequence, the counter initializes itself. That is, Frequency A mode is selected for display and the preset trigger level mode is selected. The ATTN and LPF modes are disabled, and the gate time is set to 0.1 s. If no input signal is present after the Power-Up cycle, 00000000 will appear on the display. The power-up initialize state is listed in Table 3-1.

Table 3-1. Power-Up Initialize States

FUNCTION	STATE
REMOTE/LOCAL	LOCAL
GATE TIME	0.1 s
MANUAL LEVEL	OFF
WAIT-TO-SEND	OFF
DISPLAY DIGITS	NORMAL
FUNCTION	FREQ A
X20 ATTN	X1
FILTER	OFF
REMOTE DISPLAY	OFF

3-27. Any failure during the power-up cycle will cause an error message to be displayed momentarily. After the error is displayed, the counter will attempt to operate normally.

3-28. Error Messages

3-29. The counter will display error messages whenever the instrument enters an error state. Errors can occur either during self-test or after an improper operation has been attempted through the interface.

3-30. If an error occurs during power-up self-test, error messages will appear on the display. The message will be displayed for approximately one second to give the operator sufficient time to read the message. One second after the error is displayed, the counter will attempt to operate normally.

3-31. If an error occurs during the power-up self-test, the ERROR annunciator will be turned on. This annunciator will stay on as long as the instrument does not enter the diagnostic mode to warn the operator of potentially inaccurate results.

3-32. Several types of errors can occur when an improper operation is attempted through the interface. Whenever an error message is generated because of an illegal operation, the error message will

be displayed until the RESET/LOCAL key is pressed or a DCL (device clear) command is sent to the counter by the controller. Illegal commands can either be commands not recognizable to the counter or commands which are recognizable, but are invalid if the counter is in the diagnostic or talk only modes.

3-33. Instrument error messages are listed in *Table 3-2*.

Table 3-2. Error Messages

Error	Messages
10	Self-test error
50	Unrecognizable mnemonic in command
51	Illegal numeric in command
52	First character of command is illegal
53	Illegal character in the "DR" (remote display) command
55	Invalid HP 5384A/85A command or HP-IL protocol or frame error
56	Invalid diagnostic command
60	ROM failure in I/O processor
61	RAM failure in I/O processor
70	Controller connected to talk-only instrument

3-34. If the fuse in the Channel B input opens, the message "INPUT ERROR" will appear on the display.

3-35. FRONT PANEL FEATURES

3-36. The front panel controls, indicators, and connectors are shown in *Figures 3-7* through *3-9*.

3-37. The following paragraphs describe the general purpose and use of the operator keys and controls. They are discussed by functional grouping, as follows:

- a. ON/STBY
- b. A CHANNEL
- c. B CHANNEL and A&B
- d. GATE and DISPLAY DIGITS
- e. RESET/LOCAL and CHECK
- f. INPUTS

3-38. ON/STBY

3-39. The ON/STBY switch connects or disconnects the output from the +5-volt supply to the rest of the instrument. It does not control the ac power line at the primary of the power transformer. If Option 004, the ovenized oscillator is installed, +5 volts is supplied

to the oscillator whether the power switch is in the STBY (standby) mode or in the ON mode (with the ac power cord or external dc connected). *Figure 3-1* shows the ON/STBY switch.

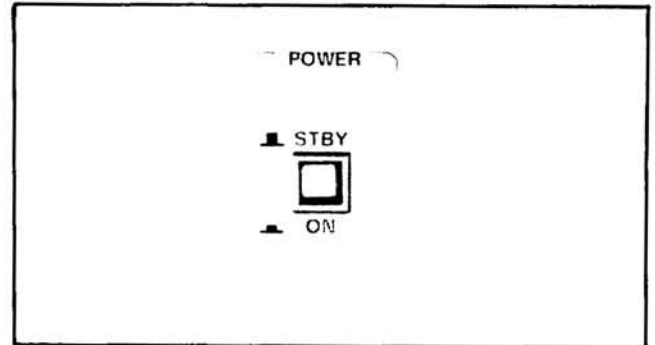

Figure 3-1. Front Panel ON/STBY Switch

3-40. A CHANNEL

3-41. Function selection for the HP 5384A and HP 5385A is accomplished through a simple one key per function keyboard. You may select from four function modes (labeled in black) accessible from the four keys grouped under A. The arrows appearing in the bottom of the display identifies which functions are active. The four functions in the A channel group are: **FREQ**, **X20 ATTN**, **PER**, **FILTER**. Refer to *Figure 3-2*, Front Panel A Channel Function Keys.

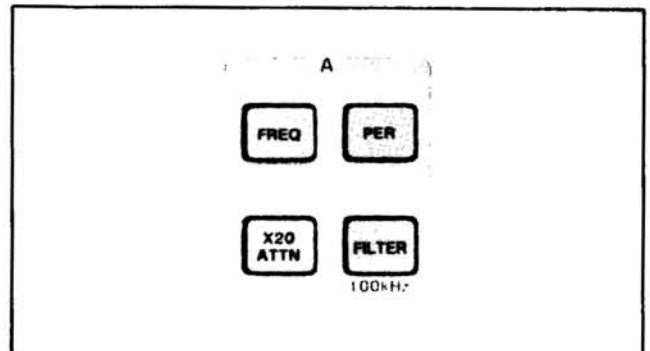

Figure 3-2. Front Panel A Channel Function Keys

3-42. **FREQ** key selects the frequency mode of operation for the A channel input. The frequency range of Channel A in both counters is 10 Hz to 100 MHz. When Channel A is selected, a black arrow appears in the bottom of the LCD over the "A" label located directly below the display window and the frequency at input A is measured and displayed.

3-43. If the counter has just been powered-up, Channel A is automatically selected (initialize mode) with a gate time of 0.1 s. If the counter has been

operated since being powered-up, the frequency measurement is made using the last gate time selected.

3-44. PER key selects the period mode of operation for the Channel A input. When the PER key is pressed, the period of the signal at input A is measured. The measurement is automatically made using the last gate time selected. The gate time is displayed in the right side of the LCD. As in frequency A, the resolution of the measurement is affected by the gate time, since the HP 5384A/85A are reciprocal counters.

3-45. Reciprocal counters use the gate time to accumulate events (cycles of input signal) during the length of the gate time. The gate time is divided by the number of events (by the microcomputer) to determine the average period of the signal. The longer the gate time, the larger number of events are accumulated. An increased number of accumulated events will increase the resolution of the measurement.

3-46. X20 ATTN key provides attenuation of the input signal on Channel A by a factor of approximately 20. Each press of the X20 ATTN key toggles between enabling and disabling an attenuation circuit. When a black arrow appears in the LCD above the "ATTN" label, the signal is attenuated. When no arrow appears, the signal is not attenuated.

3-47. The X20 ATTN sets the sensitivity of the Channel A input to either 10 mV rms or 200 mV rms range if the MANUAL TRIG LEVEL A control (discussed later) is in midrange position or disabled. The X20 ATTN operates independently of the front panel key MAN LEVEL. When the MAN LEVEL key is enabled, the X20 ATTN function will cause the range of the MANUAL TRIG LEVEL A control to increase approximately 20 times.

3-48. The FILTER key provides a 100 kHz Low Pass Filter that can be toggled into or out of the Channel A signal path. The Low Pass Filter will attenuate frequencies above 100 kHz. When the FILTER is in the signal path, a black arrow will appear in the LCD above the label "FILT".

3-49. The FILTER will improve the accuracy and resolution of frequency measurements below 100 kHz by blocking high frequency signals and noise that may be riding on the low frequency being measured.

3-50. B Channel and A&B

3-51. Figure 3-3 shows the front panel B and A&B function keys. The FREQ key selects the frequency

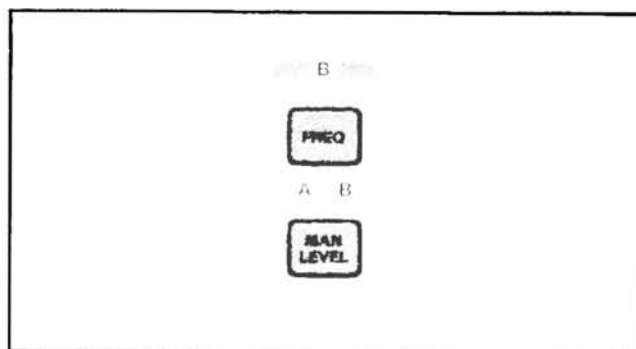

Figure 3-3. Front Panel B and A&B Function Keys

mode of operation for the B Channel input for display on the LCD. Channel B frequency range for the HP 5384A is 50 MHz to 225 MHz. Channel B frequency range for the HP 5385A is 90 MHz to 1000 MHz.

3-52. When channel B is selected, a black arrow appears in the bottom of the LCD over the "B" label located directly below the display window.

3-53. MAN LEVEL key enables or disables the front panel MANUAL TRIG LEVEL A/MANUAL ATTN LEVEL B control in the INPUTS section.

3-54. When the MAN LEVEL control is enabled (on), an arrow will appear in the LCD above the MAN LVL label. The trigger level of channel A becomes manually variable and the attenuation range becomes manually adjustable in Channel B.

3-55. When the MAN LEVEL control is disabled (off), the MANUAL TRIG LEVEL A/MANUAL ATTN LEVEL B control has no effect on input sensitivity of either channel. Channel A sensitivity is maximum (<10 mV rms) and Channel B sensitivity is controlled by an automatic gain circuit for improved noise rejection.

3-56. GATE and DISPLAY DIGITS

3-57. The GATE keys are shown in Figure 3-4. The GATE keys select the approximate gate time in decade ranges. The actual gate time is determined by the microcomputer.

3-58. The 0.1 s, 1.0 s, and 10 s keys select gate times from 0.1 second to 10 seconds for frequency, period and check measurements.

3-59. The greater the gate time the greater the accuracy and the number of digits of resolution you may obtain.

- 0.1 s 3 to 8 digits
- 1.0 s 3 to 9 digits
- 10 s 3 to 10 digits

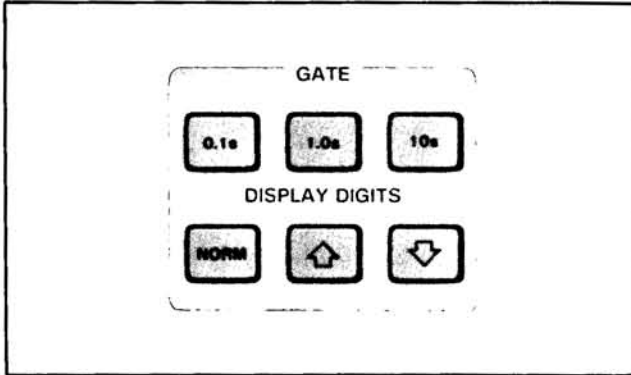

Figure 3-4. Front Panel GATE Select DISPLAY DIGITS Keys

If the most significant digits of a measurement are between 1.0 and 1.299... one extra digit is displayed, giving a maximum of 11 digits.

3-60. The DISPLAY DIGITS keys are shown in Figure 3-4. They select the number of digits displayed on the LCD. However, these keys do not affect the resolution of the measurement sent over the interface bus. Measurements are always sent with maximum resolution over the interface.

3-61. NORM key selects the normal display resolution of eight digits and a three letter units annunciation.

3-62. The measurement display will begin on the left of the LCD (character position 1) and occupy the eight leftmost character positions. The three rightmost digits (character positions 10, 11, and 12) are used for units annunciation. Character position nine is left blank.

Example: 10.000000 MHz.

3-63. \uparrow key will cause the number of digits displayed to increase to eight maximum for period measurements and 11 for frequency measurements. One press of the key causes one increment of digits displayed. When more than eight digits are displayed, the scale annunciation is reduced to only one character.

Example: 101.23456789M

3-64. This key will not affect the data sent over the interface. The counter will not display digits beyond the calculated LSD. That is, if you ask for 11 digit resolution, you may get 7, 8, 9, 10, or 11 digits.

3-65. \downarrow key will cause the number of digits displayed to decrease to a minimum of three digits. One

press of the key decreases the number of digits displayed by one digit.

6-66. Changes do not show on the display until completion of the next gate cycle, which could be up to 10 seconds. A new gate cycle is initiated when any key on the front panel is pressed. So, pressing any key on the front panel may cause a delay of up to 10 seconds before you will see the expected change in the display.

3-67. RESET/LOCAL and CHECK

3-68. The RESET/LOCAL and CHECK keys are shown in Figure 3-5.

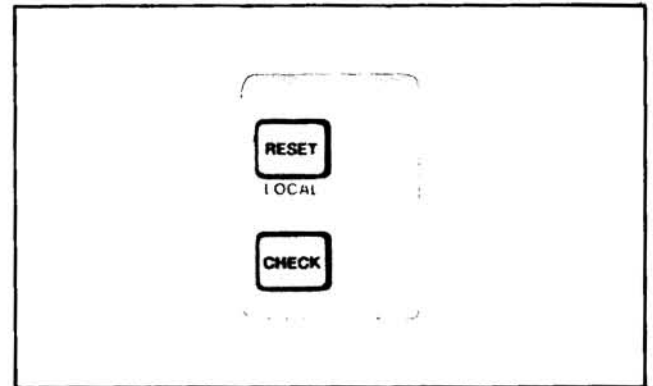

Figure 3-5. Front Panel RESET/LOCAL and CHECK Keys

3-69. When the counter is in the remote state and the local lockout (LLO) is not enabled, pressing the blue RESET/LOCAL key will return the counter to local keyboard control. The REM (remote) indicator arrow at the bottom left of the display will disappear. All functions and controls previously selected remain and a new measurement is initiated with the display reset to "00000000". If LLO is active, the RESET/LOCAL key as well as all other front panel keys are disabled.

3-70. If diagnostics are being executed while the counter is in either the local or remote state and the RESET/LOCAL key is pressed, the counter exits the diagnostic mode and defaults to the initialize mode of local operation.

3-71. If the counter is in local and not executing diagnostics, pressing the RESET/LOCAL key resets the display and initiates a new measurement.

3-72. The CHECK key is used to initiate tests that verify proper operation of the oscillator, shift register, microcomputer, display operation, and other hardware.

3-73. INPUTS

WARNING

DURING BATTERY OPERATION WITH THE MAINS POWER CORD DISCONNECTED FROM THE MAINS SUPPLY, THE FRONT AND REAR PANELS WILL FLOAT AT THE VOLTAGE APPLIED TO SIGNAL COMMON (INPUT BNC CONNECTOR SHELL). TO AVOID THE RISK OF ELECTRIC SHOCK DURING BATTERY OPERATION, ENSURE THE VOLTAGE APPLIED TO SIGNAL COMMON (BNC SHELL) DOES NOT EXCEED 42V PEAK.

3-74. The INPUTS section consists of two input BNC type connectors and a MANUAL TRIG LEVEL A/MANUAL ATTN LEVEL B single-turn potentiometer that controls the trigger level for channel A and manual attenuation for channel B. Figure 3-6 shows the INPUTS section.

3-75. Signals to be measured are connected to either channel A or channel B BNC connectors.

3-76. MANUAL TRIG LEVEL A/MANUAL ATTN LEVEL B is enabled or disabled by the MAN LEVEL key. When disabled, the MANUAL TRIG LEVEL A/MANUAL ATTN LEVEL B control has no effect on input sensitivity of Channel A or B. Channel A sensitivity is maximum and Channel B sensitivity is controlled by an automatic gain control circuit. After power-up, the control is automatically disabled (initialize mode).

3-77. When the MANUAL TRIG LEVEL A/MANUAL ATTN LEVEL B control is enabled, an arrow will appear on the LCD above the label MAN LVL. The DC offset level of Channel A input is manually variable. A variable DC offset has the effect of being a polarity and trigger level control. When the X20 ATTN is disabled, the trigger level of input A may be set from -0.1 volts to +0.1 volts peak. At midrange, 0.0 volt level, Channel A input sensitivity will be approximately 10 mV rms or ± 15 mV peak. If the X20 ATTN is enabled, these values increase by a nominal factor of 20.

3-78. When the MANUAL TRIG LEVEL A/MANUAL ATTN LEVEL B control is enabled, Channel B attenuation becomes manually variable. See the specifications in Section I.

3-79. There are two input BNC connectors; Channel A and Channel B. Channel A input frequency range is from 10 Hz to 100 MHz for the HP 5384A and HP 5385A. Channel B input frequency range is 50 MHz to 225 MHz for the HP 5384A and 90 MHz to 1.0 GHz for the HP 5385A. The input of the HP 5385A Channel B is protected by a fuse.

3-80. Both inputs are ac coupled with dc blocking up to 350 Vdc.

3-81. REAR PANEL FEATURES

3-82. A number of signal inputs, outputs, connectors and controls are provided on the rear panel.

3-83. The Input/Output interface connector provides optional remote control capabilities with either

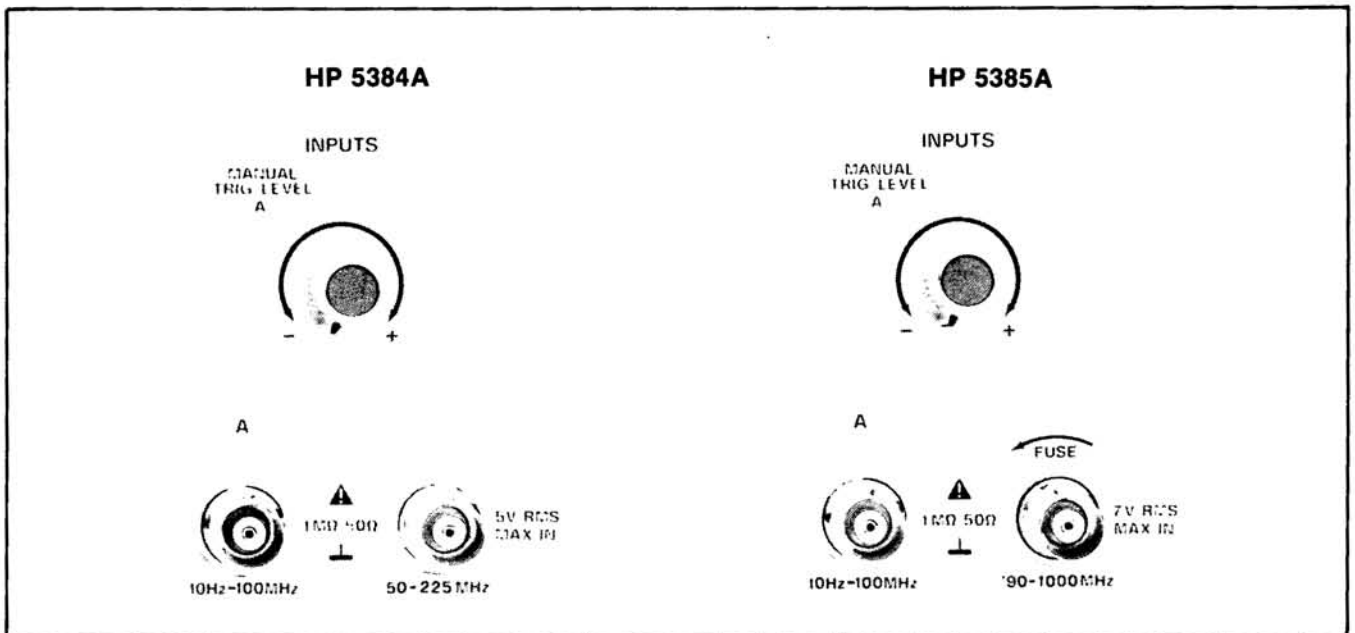

Figure 3-6. Front Panel INPUTS Section

the Hewlett-Packard Interface Bus (HP-IB) or the Hewlett-Packard Interface Loop (HP-IL). Option 003 is HP-IL.

3-84. The interface address switch (ADDR) is a seven-position switch that is used to manually set the remote control address of the counter. The five rightmost switch positions are externally accessible and can be used by the operator for setting the address. The two leftmost switch positions are not used for normal operation. For a complete description of address selection, refer to *Table 3-4, Address Selection*, in the Remote Programming Instructions in this section.

3-85. The HP-IB and HP-IL capabilities of the counter are listed above the interface port. For a complete description of the listed capabilities, refer to paragraph 3-118, Interface Commands.

3-86. The AC LINE INPUT connector accepts the ac input power cord. The protective grounding conductor also connects to the instrument through the ac power connector.

3-87. The LINE SELECT switch selects the instrument line voltage. The switch selects either 115 or 230 volts. The number visible on the switch indicates the nominal line voltage to which the instrument must be connected for proper operation.

3-88. The DC FUSE is a two-ampere fast-blow fuse for the protection of the dc power supply to the instrument. The dc fuse is the main protection for the counter. The fuse value should be two ampere 3AG fast-blow.

3-89. The EXT DC INPUT power connector accepts the two conductor dc input power cable. Input voltage range is from 9 volts to 15 volts dc and 1.0 ampere maximum. The EXT DC INPUT is fuse protected for a 2.0 ampere surge current.

3-90. The 10 MHz IN/OUT BNC connector provides a 10 MHz signal that may be used for calibration when the INT EXT switch is in the INT position. When the INT EXT switch is in the EXT position, the IN/OUT BNC connector becomes the external reference input for the counter.

3-91. EXTERNAL DC OPERATION

3-92. For external dc operation, connect the dc power cable to the EXT DC INPUT connector. Connect the other end to a dc power source of 9-15 volts and 500 mA minimum. If Option 005 battery pack is installed, the external dc power source should provide a minimum dc current of 700 mA to allow for battery charging.

3-93. MAKING FREQUENCY AND PERIOD MEASUREMENTS

WARNING

DURING BATTERY OPERATION WITH THE MAINS POWER CORD DISCONNECTED FROM THE MAINS SUPPLY, THE FRONT AND REAR PANELS WILL FLOAT AT THE VOLTAGE APPLIED TO SIGNAL COMMON (INPUT BNC CONNECTOR SHELL). TO AVOID THE RISK OF ELECTRIC SHOCK DURING BATTERY OPERATION, ENSURE THE VOLTAGE APPLIED TO SIGNAL COMMON (BNC SHELL) DOES NOT EXCEED 42V PEAK.

3-94. The recommended sequence for setting-up and making a measurement with the HP 5384A or HP 5385A Frequency counter is given below.

- a. Set the power switch to ON. The counter should perform a power-up self-check, then preset to the power-up initialize settings shown in *Table 3-1*.
- b. Press the key for the desired operating mode (frequency, period etc.).
- c. Connect a signal into the channel selected.
- d. If the display is unstable, use the attenuator, filter, or manual trigger level control and adjust for a stable reading. The above mentioned controls have limitations. They cannot compensate for excessively noisy or unstable signal sources.
- e. If desired, select a gate time and the number of display digits desired.

NOTE

The display for frequency measurements of less than Hertz will have a "less than" symbol (<) on the left of the Hertz symbol (Hz). Refer to *Table 3-3*.

Table 3-3. Units Display Format

FUNCTION	UNITS	
	<=8 DIGITS	>8 DIGITS
FREQUENCY A/ FREQUENCY B	< HZ HZ KHZ MHZ GHZ	< H K M G
PERIOD A	KSC SEC MS US NS	
CHECK	MHZ	M

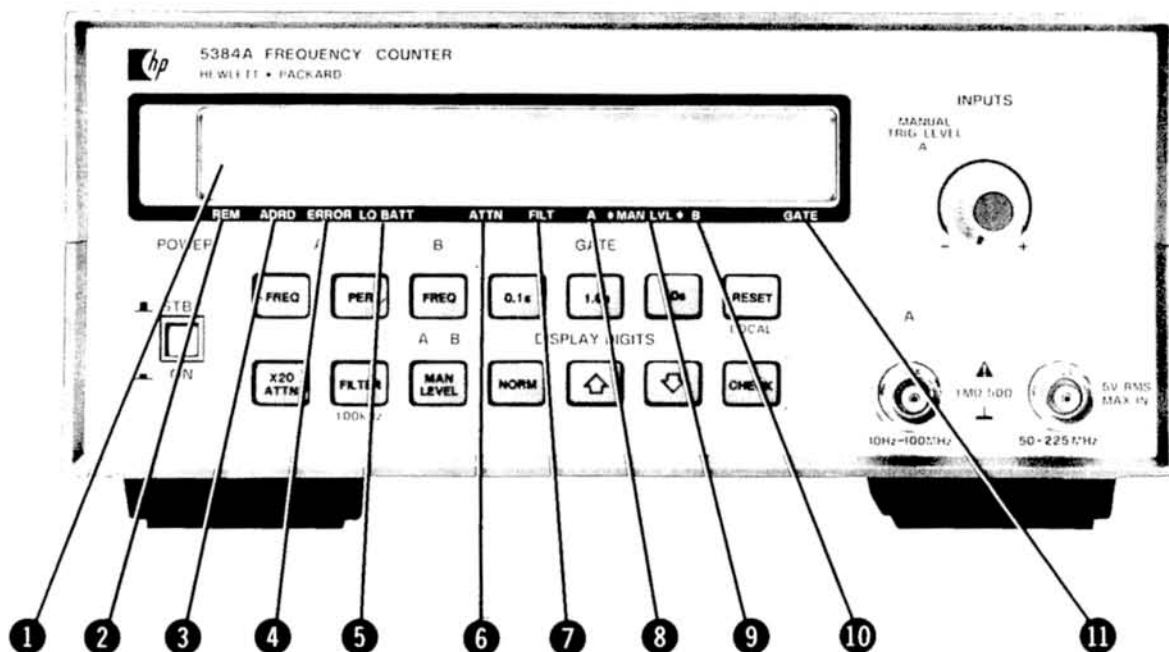

- 1 DISPLAY The liquid Crystal Display contains the 12-digit, 14-segment display.
- 2 REM An arrow appears above the REM (remote) label indicating the counter is in remote operation. The arrow does not appear in local operation.
- 3 ADDR An arrow appears above the ADDR (addressed) label indicating the counter is addressed by the controller. When the counter is addressed it may or may not be in remote operation.
- 4 ERROR An arrow appears above the ERROR (error) label when a failure occurs in the micro-processor. All other failures will cause an error number ("Ernn") to appear in the display.
- 5 LO BATT An arrow appears above the LO BATT (low battery) label when the instrument is operating from Option 005 and the battery has approximately 20 minutes of capacity remaining.
- 6 ATTN An arrow appears above the ATTN (attenuator) label when the X20 attenuator is in the Channel A signal path.
- 7 FILT An arrow appears above the FILT (filter) label when the 100 kHz low pass filter is in the A Channel signal path.
- 8 A An arrow appears above the "A" label when the counter is set-up to make a frequency measurement or period measurement on Channel A.
- 9 -MAN LVL- An arrow appears above the -MAN LVL- label when the MANUAL TRIG LEVEL A/ MANUAL ATTN LEVEL B control is enabled.
- 10 B An arrow appears above the "B" label when the counter is set-up to make a frequency measurement on Channel B.
- 11 GATE An arrow appears above the GATE label to indicate that a measurement is in progress.

Figure 3-7. Front Panel Indicators

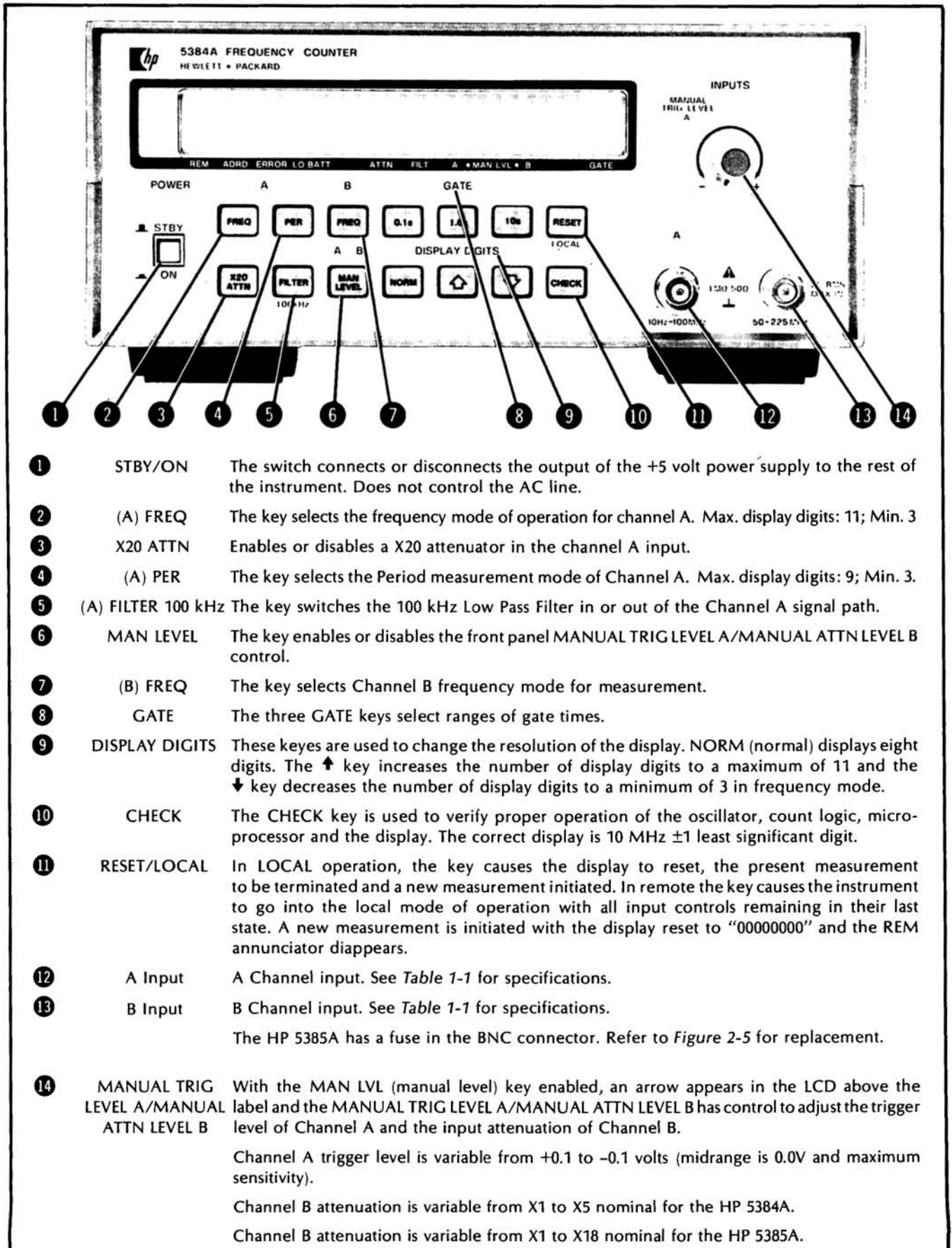

- ① STBY/ON The switch connects or disconnects the output of the +5 volt power supply to the rest of the instrument. Does not control the AC line.
- ② (A) FREQ The key selects the frequency mode of operation for channel A. Max. display digits: 11; Min. 3
- ③ X20 ATTN Enables or disables a X20 attenuator in the channel A input.
- ④ (A) PER The key selects the Period measurement mode of Channel A. Max. display digits: 9; Min. 3.
- ⑤ (A) FILTER 100 kHz The key switches the 100 kHz Low Pass Filter in or out of the Channel A signal path.
- ⑥ MAN LEVEL The key enables or disables the front panel MANUAL TRIG LEVEL A/MANUAL ATTN LEVEL B control.
- ⑦ (B) FREQ The key selects Channel B frequency mode for measurement.
- ⑧ GATE The three GATE keys select ranges of gate times.
- ⑨ DISPLAY DIGITS These keys are used to change the resolution of the display. NORM (normal) displays eight digits. The ↑ key increases the number of display digits to a maximum of 11 and the ↓ key decreases the number of display digits to a minimum of 3 in frequency mode.
- ⑩ CHECK The CHECK key is used to verify proper operation of the oscillator, count logic, micro-processor and the display. The correct display is 10 MHz ±1 least significant digit.
- ⑪ RESET/LOCAL In LOCAL operation, the key causes the display to reset, the present measurement to be terminated and a new measurement initiated. In remote the key causes the instrument to go into the local mode of operation with all input controls remaining in their last state. A new measurement is initiated with the display reset to "00000000" and the REM annunciator disappears.
- ⑫ A Input A Channel input. See Table 1-1 for specifications.
- ⑬ B Input B Channel input. See Table 1-1 for specifications.
The HP 5385A has a fuse in the BNC connector. Refer to Figure 2-5 for replacement.
- ⑭ MANUAL TRIG LEVEL A/MANUAL ATTN LEVEL B With the MAN LVL (manual level) key enabled, an arrow appears in the LCD above the label and the MANUAL TRIG LEVEL A/MANUAL ATTN LEVEL B has control to adjust the trigger level of Channel A and the input attenuation of Channel B.
Channel A trigger level is variable from +0.1 to -0.1 volts (midrange is 0.0V and maximum sensitivity).
Channel B attenuation is variable from X1 to X5 nominal for the HP 5384A.
Channel B attenuation is variable from X1 to X18 nominal for the HP 5385A.

Figure 3-8. Front Panel Controls

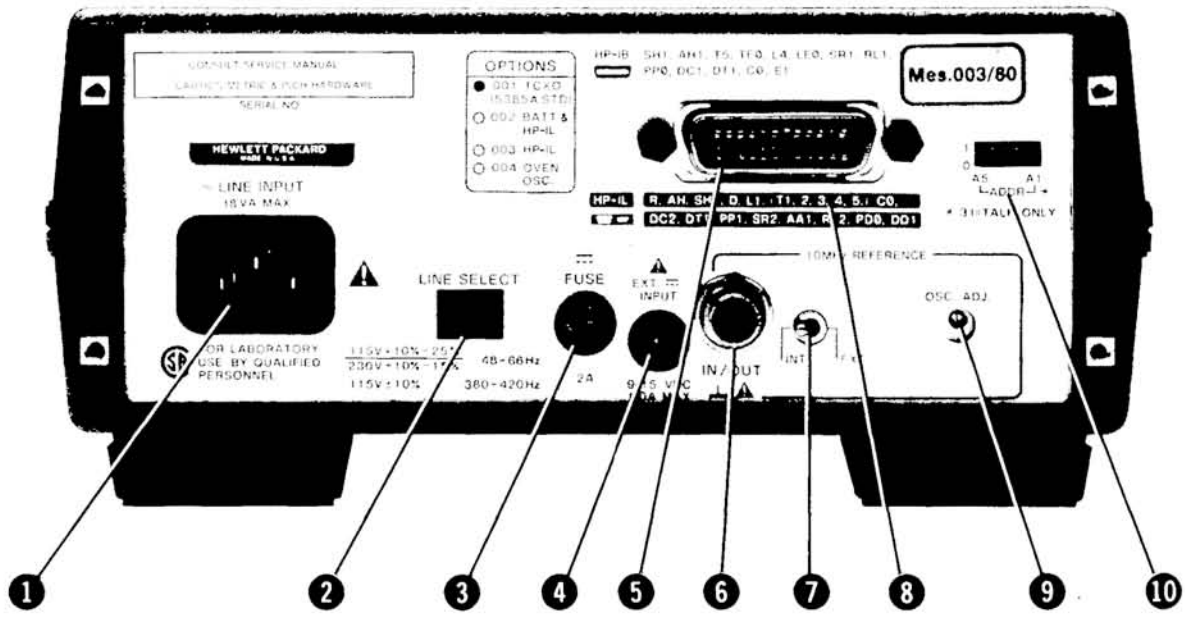

- ① AC LINE INPUT The connector accepts the ac input power cord.
- ② LINE SELECT The LINE SELECT switch selects line voltage of 115 or 230 volts. The selected voltage range is visible on the switch.
- ③ DC FUSE The DC FUSE is a two ampere fast blow fuse. Provides main instrument protection.
- ④ EXT DC INPUT The EXT DC INPUT power connector accepts the two-conductor input power cable. Input voltage range is from 9 volts to 15 volts dc and 1.0 ampere maximum.
- ⑤ Interface Connector The input/output interface connector provides optional remote control capabilities with either HP-IL (Option 003) or HP-IB. HP-IB is shown.
- ⑥ 10 MHz IN/OUT BNC Connector The 10 MHz IN/OUT BNC connector provides a 10 MHz calibration signal when the INT EXT switch is in the INT position. With the switch in the EXT position, the IN/OUT BNC connector becomes the external reference input for the counter.
- ⑦ INT EXT The switch selects the internal 10 MHz oscillator or an external reference oscillator.
- ⑧ Interface Capabilities The interface capability label lists the standard interface functions of the counter for the HP-IB or HP-IL.
- ⑨ STD. and TCXO OSC ADJ ONLY The internal time base oscillator is adjusted through this opening.
- ⑩ ADDR (address) The address switch is used to manually set the remote control address of the counter. The five rightmost switch positions determine the address.

Figure 3-9. Rear Panel Features

3-95. REMOTE PROGRAMMING

3-96. Introduction

3-97. The HP 5384A and HP 5385A frequency counters (with HP-IB) is compatible with the Hewlett-Packard Interface Bus, or (with Option 003) are compatible with the Hewlett-Packard Interface Loop. Remote programming allows the instrument to respond to remote control instructions and output measurement data via the interface. At the simplest level, the counter can output data in the talk only mode to other devices such as a printer. In more sophisticated systems, a controller can remotely program the counter to perform a specific type of measurement, trigger the measurement, and output the results.

NOTE

HP-IB is Hewlett-Packard's implementation of IEEE Std. 488-1978, "*Standard Digital Interface for Programmable Instrumentation*".

3-98. The programming information in this section, except where noted, applies to both HP-IB and HP-IL interfaces. In general, the HP-IB may be considered a subset of HP-IL, as almost all capabilities of the HP-IB are also capabilities of the HP-IL. Every effort has been made to make the programming of the counter consistent, regardless of which interface is configured.

3-99. To remotely program the counter efficiently, the operator must be familiar with the selected controller, the configured interface, and the local (manual) operation of the counter. Typical controllers for the HP-IB are the HP 9825A/B, HP 9826A, HP 9830A, HP 9835/45A, or HP 85A. Typical controllers for the HP-IL are the HP 85A and the HP 41CV. Users of the HP-IB interface should find the following manuals useful background information:

Condensed Description of the Hewlett-Packard Interface Bus (P/N 59401-90030)

HP-IB programming Hints for Selected Instruments (P/N 59300-90005)

Tutorial Description of the Hewlett-Packard Interface Bus (P/N 5952-0156)

3-100. Users of the HP-IL interface may be unfamiliar with the HP-IL system. An introductory description of the interface system, and the Hewlett-Packard Interface Loop (HP-IL) is provided later in this section. More detailed information on the HP-IL is available in the following publications:

HP-IL Interface Specification (P/N 82166-90017)

The HP-IL System: An Introductory Guide to the Hewlett-Packard Interface Loop (Published by OSBORN/McGraw-Hill, 630 Bancroft Way, Berkeley, CA 94710)

Product Note 5384A/5385A (P/N 02-5952-7700)

3-101. INTERFACE DESCRIPTION

3-102. Hewlett-Packard Interface Bus (HP-IB)

3-103. The Hewlett-Packard Interface Bus (HP-IB) system utilizes a party-line bus structure (devices share signal lines) to which a maximum of 15 devices may be connected in one continuous bus. Sixteen signal lines and 8 ground lines are used to interconnect devices in parallel arrangement and maintain an orderly flow of device and interface related information.

3-104. Hewlett-Packard Interface Loop (HP-IL)

3-105. The Hewlett-Packard Interface Loop (HP-IL) is a two-wire serial interface that provides programmable control of instruments while being easy to use and understand. The controller and all devices in the loop, including the counter, are connected together in series, forming a continuous loop communications circuit. Any information (instructions or data) that is transferred among HP-IL devices is passed from one device to the next around the loop (one direction only). If the information is not intended for a particular device, that device simply passes the information on to the next device in the loop. When the proper device receives the information, that device responds as directed. In this way, the controller or the counter can send information to and receive information from each device in the loop, according to the device's capability.

3-106. The counter may be connected anywhere in the interface loop. The loop consists of up to 30 devices plus the controller using simple addressing. When installing or removing the counter (or any other device) it is a good practice to turn off the controller first. Then simply disconnect the loop in one place and connect the counter at that point. Remember, the interface cables must form a continuous loop. All HP-IL connectors are designed to ensure proper orientation and indicate the direction of information transfer.



3-107. INTERFACE FUNCTIONAL OVERVIEW

3-108. Each device on the interface may possess one or more of the following major device capabilities: Controller, Talker, or Listener. The controller, as the name implies, has the responsibility to control interface activity. The controller, of course, must be equipped with the proper interface module. Controllers transmit all device independent commands to other devices in the interface and usually have Talker and Listener capabilities. The counter cannot serve as a controller.

3-109. Talkers are devices that have the ability to send data or device dependent commands through the interface. Note that a talker will not actually send its data or information until told to do so by the controller. The counter has Talker capabilities. In special situations, one device may be classified as a Talk-only device and sends information to Listen-only devices. Such a system would not have a controller. For example, the counter can be configured to the Talk-only mode and send measurement results to a printer. (TALK ONLY Address = 31).

3-110. Listeners are devices with the capability to receive information over the interface. Listeners must also be enabled by the controller to receive the information.

3-111. INTERFACE SYSTEMS TERMS

3-112. The following paragraphs define the terms and concepts used to describe HP-IB and HP-IL system operations.

a. ADDRESS: Each device in the interface is assigned an address. The address is used to specify which device on the interface will receive information or send information.

b. BYTE: A byte is a unit of information consisting of eight binary digits called bits.

c. DEVICE: Any instrument or unit that is HP-IB or HP-IL compatible is called a device.

d. DEVICE DEPENDENT: An action a device performs in response to information sent through the interface. The action is characteristic of a particular instrument and will probably vary from device to device.

e. DEVICE INDEPENDENT COMMAND: A command predefined by the interface standard to have a specified bit pattern and resulting action.

f. DEVICE DEPENDENT COMMAND: A command not predefined by the interface standard, which is specific to a particular instrument or family of instruments.

g. POLLING: Polling is a process typically used by a controller to locate a device that has requested service from the controller. There are two types of polling; Serial Poll and Parallel Poll:

1. Serial Poll. When the controller executes a serial poll, the addressed device sends one byte of operational information called a status byte. If more than one device in the interface is capable of requesting service, each device on the interface must be serial polled until the device that requested service is located.
2. Parallel Poll. When the controller executes a parallel poll, all devices on the interface respond, each one setting or clearing a particular data bit to indicate whether or not it requested service.

3-113. ADDRESS SELECTION

3-114. MANUAL ADDRESSING. To use the counter in a system, set the rear panel address switches to the desired address. Addresses 0 through 30 represent the addressable mode range. Address 31 selects the Talk-only mode. The addressable mode is used when the counter functions as a talker and a listener. The TALK ONLY mode (Figure 3-10) is employed when the counter is operating in an output-only condition (no controller on the bus) and sends its data to another device on the bus, such as a printer, set to LISTEN ONLY.

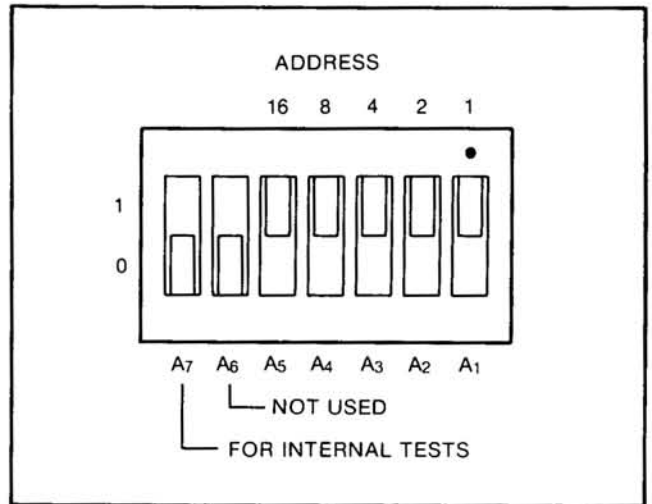

Figure 3-10. HP 5384A and HP 5385A Address Switches Shown in Address 31



3-115. The five rightmost switches, A₅ through A₁, set the address of the counter. Table 3-4 shows all possible address settings and the corresponding ASCII codes used by some controllers for talk and listen. The counter is factory set to address 03 as shown in Table 3-4. Address 21 is not allowed because that address is assigned to the controller device.

3-116. AUTOADDRESSING. Autoaddressing is a method of setting the instrument's address, unique to HP-IL, and is provided by the HP-85A, HP 41C/CV. When autoaddressing is enabled, each device in the loop is assigned an address by the controller. The assigned address will probably be different from the factory preset address. The counter, for example, has a preset address of 03. If the counter is the only device in the loop with the controller, the controller will assign it an address of "1". The address permits the controller to specify or select a particular device in the loop when sending commands. As shown in Figure 3-11, addresses are assigned to particular devices sequentially around the loop in the direction of information flow. The first device after the controller is assigned an address of "1". The second device is assigned the address of "2", and so on around the loop. The controller has an address of "0".

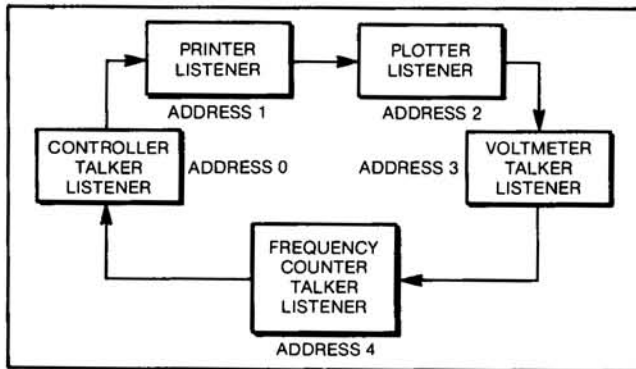

Figure 3-11. Typical HP-IL System Addressing

3-117. The interface status of the counter is indicated on the front panel by an arrow appearing above the REM ADDR labels on the front panel.

3-118. INTERFACE COMMANDS

3-119. The commands that the counter recognizes can be separated into two classes: device dependent commands and device independent commands. Device dependent commands are those that are unique to the instrument and are defined by the instrument designer. They are normally sent to an instrument as ASCII strings. A detailed description of device dependent commands begins in paragraph 3-138, Device Dependent Commands.

Table 3-4. Address Selection

Rear panel address switch:

ADDRESS

16 8 4 2 1

A₇ A₆ A₅ A₄ A₃ A₂ A₁

NOT USED
FOR INTERNAL TESTS

(Shown in addressable mode, and address 03)

NOTE
*Select the decimal address from the table below and set the address switches to the corresponding positions.

ASCII CODE CHARACTER		ADDRESS SWITCHES					5-BIT DECIMAL CODE
LISTEN	TALK	A ₅	A ₄	A ₃	A ₂	A ₁	
SP	@	0	0	0	0	0	00
!	A	0	0	0	0	1	01
"	B	0	0	0	1	0	02
#	C	0	0	0	1	1	03
\$	D	0	0	1	0	0	04
%	E	0	0	1	0	1	05
&	F	0	0	1	1	0	06
'	G	0	0	1	1	1	07
(H	0	1	0	0	0	08
)	I	0	1	0	0	1	09
*	J	0	1	0	1	0	10
+	K	0	1	0	1	1	11
,	L	0	1	1	0	0	12
-	M	0	1	1	0	1	13
.	N	0	1	1	1	0	14
/	O	0	1	1	1	1	15
0	P	1	0	0	0	0	16
1	Q	1	0	0	0	1	17
2	R	1	0	0	1	0	18
3	S	1	0	0	1	1	19
4	T	1	0	1	0	0	20
5	U	1	0	1	0	1	21
6	V	1	0	1	1	0	22
7	W	1	0	1	1	1	23
8	X	1	1	0	0	0	24
9	Y	1	1	0	0	1	25
:	Z	1	1	0	1	0	26
;	[1	1	0	1	1	27
<	\	1	1	1	0	0	28
=]	1	1	1	0	1	29
>	~	1	1	1	1	0	30



3-120. Device independent commands, on the other hand, are defined by the interface standard document and are the same in all instruments. These commands are identified by a three letter mnemonic such as GTL, which represents Go to Local. Device independent commands are sent as specially encoded bytes on the interface and not as ASCII strings. Thus these commands cannot be sent using the OUTPUT statement on the HP-85A. However, many controllers do incorporate a command of the form SEND7;CMDnnn, where nnn is the decimal equivalent to the bit pattern corresponding to a particular device independent command.

3-121. INTERFACE CAPABILITIES

3-122. Since the device independent commands are standardized and are the same in all instruments, the functions these commands perform can be listed on the instrument in a standardized manner. This is known as the interface capability label.

HP-IB SH1, AH1, T5, TE0, L4, LE0, SR1, RL1, PP0, DC1, DT1, C0, E1

HP-IL R, AH, SH1, D, L1, (T1, 2, 3, 4, 5,), C0, DC2, DT1, PP1, SR2, AA1, RL2, PD0, DD1

3-123. The number following the interface function code indicates the particular capability of that function.

3-124. Table 3-5 provides a list of the interface capabilities of the instrument.

3-125. META MESSAGES

3-126. In order to simplify the use of the HP-IB and HP-IL interfaces, HP has developed what is called the Meta Message concept. Rather than requiring the user to remember all the device independent messages and their interactions, useful sequences of these commands have been integrated into a single command on many of HP's controllers. For example, to clear the instrument at address 03 using the device independent commands, it is necessary to send the sequence ATN, UNL, MTA, LAD 03, SDC. In the HP-85, the command CLEAR 703 causes this sequence to be sent with no further user interaction. This greatly simplifies the use of the interface.

3-127. Many of the meta messages as implemented on the HP-85A may be sent in either of two forms, either with or without addressing. The form with addressing will normally listen address the instrument. For example, the command REMOTE 703 will

Table 3-5. Interface Capabilities

HP-IB	HP-IL	DESCRIPTION
SH1	SH1	The instrument can generate messages.
AH1	AH	The instrument can interpret received messages.
	R	The instrument can receive messages.
	D	The instrument can drive the HP-IL loop.
T5	T12345	The instrument can function as a talker. In addition, it can operate as a Talker Only instrument and can respond to serial poll, send device ID, and send accessory ID.
TE0		The instrument cannot function as an extended talker.
L4	L1	The instrument can function as a listener. It will accept commands via the interface. In addition, it will untalk itself if addressed as a listener.
LE0		The instrument cannot function as an extended listener.
SR1	SR2	The instrument can generate a service request. In addition, the instrument can generate an IDY frame on HP-IL.
RL1	RL2	The instrument can operate in both remote and local modes. In addition, it can respond to local lockout.
PP0	PP1	The instrument does not support parallel poll on HP-IB. On HP-IL, the instrument does support parallel poll.
DC1	DC2	The instrument supports both the device clear (DCL) and selected device clear (SDC) commands.
DT1	DT1	The instrument can be remotely triggered.
C0	C0	The instrument cannot function as a controller.
	AA1	The instrument can be remotely addressed with simple (non-extended) addresses.
	PD0	The instrument cannot be remotely powered down.
	DD1	The instrument responds to the device dependent listener (DDL) command.
E1		The instrument places one load on the HP-IB system.

send REN and then make the instrument a listener. In the following tables, the form with addressing is shown.

3-128. Table 3-6 lists the meta messages, their results in the counter, and typical interface message sequences corresponding to them. The sequences are typical in that different controllers may send different sequences, while still obtaining the same results.



state. In the normal state, measurements are made continuously regardless of whether or not those measurements were read by the controller.

3-152. DR (string) Remote Display

3-153. The remote display command is legal only when the counter is in the measurement mode. If the command is received while the counter is in the diagnostic mode, an error will be flagged.

3-154. The remote display command allows the user to send any message, 12 characters in length excluding punctuation, to the LCD. A punctuation mark (comma, colon, or decimal point) can be sent between each of the characters.

3-155. Although the counter will continue making measurements, the LCD will contain the message sent with the "DR" command rather than the measurement data.

3-156. Whenever a new message is to be displayed, the remote display command must be sent. Thus each new message must be sent in the form "DRXXXXXXXX", where the X's represent the message to be displayed. Carriage return, line feed, form feed, horizontal tab, and vertical tab can be used as terminators for a remote display message. A message sent to the display will remain there until a command which causes a change in the display is sent to the counter.

3-157. The remote display mode can be terminated in several ways. Sending a "DL" (display local) command will terminate the remote display mode without changing the state of the counter in any other way. When the counter receives this command, it will clear the display and resume displaying measurement data. Sending a diagnostic command also terminates the remote display mode, but it causes the counter to exit the measurement mode as well. Pressing the RESET/LOCAL key is another way of terminating the remote display mode, however, the key will cause the counter to exit the remote state and enter the local state. Any transition from the remote state to the local state, caused by the controller, will terminate the remote display mode as well.

3-158. If an error condition is generated while the instrument is in the remote display mode, the error message will be displayed just as in any other case. However, when the error is cleared, the counter will no longer be in the remote display mode; it will begin

displaying the measurement data rather than the message contained in the LCD prior to the error condition.

3-159. DL Display Local

3-160. The display local command allows the user to terminate the remote display mode without changing the state of the counter in any other way. When the counter receives this command, it will clear the remote display message and begin displaying measurement data.

3-161. ID and SI Send Device ID

3-162. These two commands perform the same function. Whenever the counter receives either of these two commands, it will send its ID to the controller. Either "HP 5384A" or "HP 5385A" will be sent to the controller. The counter will wait until the device ID is read by the controller before it will resume taking measurements again.

3-163. SE Send Error

3-164. When the send error command is received, the instrument will send the number of the detected error (there may be more than one) to the interface bus. We recommend the "SE" command be used in a string by itself.

3-165. LCD Character Set

3-166. *Table 3-10* shows the characters the instrument can produce. Included in the table is a code needed to produce the character and how the displayed character will look.

3-167. PROGRAM EXAMPLES

3-168. The following examples demonstrate programming capabilities of the HP 5384A and HP 5385A. The first four examples are written for the HP-85A controller. The fifth example is written for the HP 41C/CV. A summary of the program operation and a line-by-line description are provided for each example.

- Example 1 Instrument Identification
- Example 2 Reading Status Byte
- Example 3 Frequency A
- Example 4 Remote Display
- Example 5 Frequency A Measurement



Table 3-6. Meta Messages

MESSAGE	DESCRIPTION/RESPONSE
DATA	A means to send device dependent command and receive measurement data. HP-IB: UNL, MTA, LADn, data HP-IL: UNL, MTA, LADn, SDA, data
TRIGGER	Starts a new measurement.
CLEAR	Will clear the display. If in error state, clears error only. UNL, MTA, LADn, SDC
REMOTE	Disables front panel keys (except for Reset/Local). REN, UNL, MTA, LADn
LOCAL	Enables the front panel keys. UNL, MTA, LADn, GTL
LOCAL and CLEAR LOCKOUT	Enables the front panel keys and clears Local Lockout. HP-IB: REN HP-IL: NRE
LOCAL LOCKOUT	Disables the Reset/Local key when in remote. LLO
SERVICE REQUEST	This command is ignored when received by the instrument. It will be sent by the instrument when an enabled service condition is present.
STATUS BYTE	Presents status information. HP-IB: UNL, MLA, TADn, SPE, data, SPD, UNT HP-IL: UNL, MLA, TADn, SST, data, UNT
STATUS BIT	Single bit parallel poll response indicates whether this instrument is requesting service. IDY
PASS CONTROL	Not supported.
ABORT	Terminates bus communications by unlistening and untalking all instruments. IFC
DEVICE ID	Causes the instrument to send the string "HP 5384A" or "HP 5385A" UNL, MLA, TADn, SDI, data
ACCESSORY ID	Causes the instrument to send the number 81 in binary. This identifies the instrument as a measuring instrument. UNL, MLA, TADn, SAI, data

3-129. Table 3-7 lists the meta messages and the HP 9825, HP-85, and HP-41C commands that correspond to them. (Only the addressed form is shown for the commands that support both the unaddressed and addressed forms. The HP-41C requires the address selection to be made using a SELECT statement.) The table assumes the instrument is set to address 03 and the interface to select code 7.

Table 3-7. Meta Messages and Controller Commands

MESSAGE	HP 9825	HP-85	HP-41C
DATA	wrt 703, A\$ red 703, A\$	OUTPUT 703; A\$ ENTER 703; A\$	OUTA INA
TRIGGER	trg 703	TRIGGER 703	TRIGGER
CLEAR	clr 703	CLEAR 703	
REMOTE	rem 703	REMOTE 703	REMOTE
LOCAL	lcl 703	LOCAL 703	LOCAL
LOCAL/CLEAR LOCKOUT	lcl 7	LOCAL 7	
LOCKOUT	llo 7	LOCAL LOCKOUT 7	
SERVICE REQUEST		STATUS 7,1; A	
STATUS BYTE	rds (703)	SPOLL (703)	INSTAT
*STATUS BIT		PPOLL (7)	
PASS CONTROL			
ABORT	cli 7	ABORTIO 7	STOPIO
*DEVICE ID		SEND 7; CMD 255	FINDID
*ACCESSORY ID		SEND 7; CMD 254	

*HP-IL only.
Typically, HP-IL uses an address code of 9nn and HP-IB uses an address code of 7nn.

3-130. SRQ, SRQ MASK, AND STATUS BYTE

3-131. SRQ and Status Byte

3-132. When in remote operation, the counter can send a service request (SRQ) to the controller to indicate the need for attention and can act as an interrupt to the current sequence of events. Typically, SRQ indicates data is ready to transmit and/or an error condition exists. The counter can send an SRQ to the controller under any, all, or none of the following conditions, as defined by the Service Request Mask. The Service Request Mask (SM command) must be set prior to the condition. Refer to paragraph 3-136.

- DATA READY. A measurement has been completed and is available for collection.
- ERROR. An Error or Failure condition exists, and is displayed.
- LOCAL. The instrument is in local.



3-133. In general, the controller can read the counter Status Byte at any time to check selected operating conditions. During remote operation, you may selectively program the counter Service Request Mask (SMnnn) to identify the conditions which you feel may require service or data collection.

3-134. Once SRQ has been sent, the controller can identify which condition or conditions caused the Service Request by reading the Status Byte. When the Status Byte is read, conditions that exist will be set to 1 whether or not enabled as a condition to generate SRQ. Sending a "rds (703)" with the HP 9825A, or "A=SPOLL (703)" with the HP-85A requests the eight-bit binary status byte. The number returned will be a decimal equivalent to the sum of the different status bits set, as shown in Table 3-8.

3-135. For example; the instrument requested service (SRQ) and reading the Status Byte returned a value of "97". This can be interpreted as 64 + 32 + 1 = 97, meaning the SRQ FLAG is set, power is on, and data is ready. The bits of the Status Byte are set regardless of the Service Request Mask. However, if that bit is masked out, it will not generate an SRQ.

3-136. Service Request Mask

3-137. Upon receipt of the Service Request Mask Command (SM Command), the instrument will load the binary value of "nnn" into the service request mask register. The SRQ line bit will be "set" if a bit in the status byte becomes set and the corresponding bit in the service request mask is set. To specify the service request mask, send the SM command, followed by the decimal number that represents the sum of the bits that you want enabled. You may send any number between "0" and "255", although only the five least significant bits are used. The binary value of "nnn" is interpreted as follows:

BIT	MEANING	(DECIMAL) WEIGHT
NOT MASKABLE		
Bit 7	Always 0	128
Bit 6	SRQ	64
Bit 5	Power On	32
MASKABLE BITS		
Bit 4	Instrument in Local	16
Bit 3	Always 0	8
Bit 2	Error or Fail Condition	4
Bit 1	Always 0	2
Bit 0	Data Ready	1

For example, sending the command "SM5" will generate a service request (SRQ) after an error

Table 3-8. HP 5384A and HP 5385A Status Byte

D7	D6	D5	D4	D3	D2	D1	D0
0	SRQ FLAG	POWER ON	LOCAL	0	ERROR or FAIL	0	DATA READY
128	64	32	16	8	4	2	1

or fail condition or data is ready (4 + 1). Sending the command "SM0" masks off (or disables) all SRQ conditions. The condition or conditions which caused the service request may be determined by reading the Status Byte.

3-138. DEVICE DEPENDENT COMMANDS

3-139. The counter will accept command strings in either upper or lower case. Spaces, commas, and semicolons between commands are interpreted as command terminators. In addition, parity bits will be ignored. Depending upon the controller, this can help to speed-up programming. The following free format command statements will produce identical results:

```
OUTPUT 703; "FU1,AT1,FI1,ML1,GA2,DN"
OUTPUT 703; "fu1,at1,fi1,ml1,ga2,dn"
```

3-140. Output Formats

3-141. Data is output to the HP-IB in the following format:

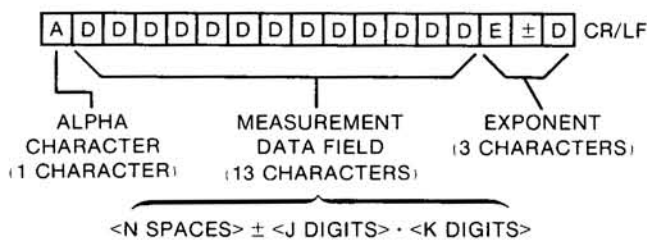

- Alpha character
- Variable number of blanks
- + or - sign
- Digit
- Decimal Point
- Variable number of digits
- E
- + or - sign
- One exponent digit
- Carriage Return
- Line Feed



EXAMPLE 1. INSTRUMENT IDENTIFICATION

The following example demonstrates how to display the identification address of the counter on the display screen of the controller. The program clears the HP 5384A/HP 5385A then requests the instrument identification. The response is read into "N\$", which is then displayed. Note: To use this example with an HP 5385A, substitute HP 5385A wherever HP 5384A is entered.

PROGRAM

```

10 REM      Example #1: INSTRUMENT IDENTIFICATION   "TAR1"
20 CLEAR @ DISP USING "5/"
30 DISP " Searching for 5384A address... " @ DISP
40 N$="NOT 5384A"
50 FOR S=700 TO 730
60 IF S=721 THEN 140
70 DISP S @ BEEP 250,75
80 SET TIMEOUT 7;100
90 OUTPUT S ;"ID"
100 ENTER S ; N$
110 IF N$="HP5384A" THEN 230
120 CLEAR S
130 ABORTIO 7
140 NEXT S
150 BEEP 200,200
160 CLEAR @ DISP USING "5/"
170 DISP "Address not found." @ DISP
180 DISP "Verify HP-IB connection and that the 5384A is not in the TALK"
190 DISP "ONLY mode."
200 DISP @ DISP "Press 'CONT' when ready."
210 PAUSE
220 GOTO 20
230 DISP @ BEEP @ DISP " HP 5384A FOUND AT ADDRESS";S;"!"
240 END
    
```

PROGRAM DESCRIPTION

- Line 10 Remarks; comments only, does not affect the program.
- Line 20 Clears the controller display only and places the cursor near the middle of the controller display screen.
- Line 30 Message inside quotes is displayed on controller display screen and the cursor skips one line.
- Line 40 Set "N\$" equal to "not 5384A".
- Line 50 Loop "S" from address 700 to 730
- Line 60 If instrument value = 721 (calculator address) then go to line 140.
- Line 70 Display instrument address and beep. The number "75" determines the length of time of the beep and "250" determines the pitch.
- Line 80 Set time out on address 7 to 100 ms.
- Line 90 Send "ID" command to instrument with address = to "S".
- Line 100 Read instrument "ID" response into "N\$".
- Line 110 If contents of "N\$" equals "5384A", then jump to line 230.
- Line 120 Clear instrument at address "S".
- Line 130 Terminates any data transfer on address 7.
- Line 140 Increment to next address.
- Line 150 Beep.
- Line 160 Clears controller display only and places the cursor near the middle of the controller display.
- Line 170 Display string within quotes on the controller display and skip on line.
- Line 180 Display string within quotes on controller screen.
- Line 190 Display string within quotes on controller screen.
- Line 200 Skip one line and display string within quotes on controller display.
- Line 210 Halt program until user presses "CONT".
- Line 220 Go to line 20.
- Line 230 Skip a line, beep and display string within quotes and the address of HP 5384A.
- Line 240 End program execution.



EXAMPLE 2. READING STATUS BYTE

The following example reads the status byte of the HP 5384A/HP 5385A by a serial poll at address 03. The value returned is input into "A". The program first displays the status byte prior to the error condition. After the error condition is generated by sending an illegal command "FU5", the program again displays the status byte of a different value.

PROGRAM

```
10 REM      Example #2:  READING STATUS BYTE      "TAR2"
20 S=703
30 CLEAR @ DISP USING "3/"
40 OUTPUT S ;"SM5"
50 A=SPOLL(S)
60 DISP "The value of the status byte      prior to the error condition is"
70 DISP "equal to";A;"."
80 DISP
90 DISP "Press 'CONT' to generate an SRQ and alter the status byte value."
100 DISP @ PAUSE
110 BEEP
120 OUTPUT S ;"FU5"
130 A=SPOLL(S)
140 DISP "The value of the status byte      after the error condition is"
150 DISP "equal to";A;"."
160 END
```

PROGRAM DESCRIPTION

- Line 10 Remarks; comments only, does not affect the program.
- Line 20 Set "S" = to 703.
- Line 30 Clears the controller display only and the cursor skips three lines. The reason for skipping 3 lines is simply to bring the cursor near the middle of the display screen.
- Line 40 Send service request mask to HP 5384/HP 5385 at address equal to "S" for error or failure condition or data ready condition.
- Line 50 Read status of HP 5384A/HP 5385A (into A) by a serial poll at address equal to "S".
- Line 60 Display message within quotes.
- Line 70 Display message within quotes and the status byte.
- Line 80 Skip one line on controller screen.
- Line 90 Display message within quotes.
- Line 100 Skip one line on controller screen and halt program execution until user presses "CONT".
- Line 110 Beep.
- Line 120 Output "FU5" command to HP 5384A/HP 5385A at address "S" ("FU5" will generate an error condition).
- Line 130 Read the status of HP 5384A/HP 5385A (into A) by a serial poll at address "S".
- Line 140 Display message within quotes.
- Line 150 Display message within quotes and status byte.
- Line 160 End program execution.



EXAMPLE 3. FREQUENCY A

The following example demonstrates how to display a Frequency A measurement on the controller display screen. The address is set to 03 and the "IN" command is sent to the HP 5384A/HP 5385A. The response is read into "A\$", which is then displayed.

PROGRAM

```

10 REM      Example #3:   FREQUENCY A       "TAR3"
20 S=703
30 OUTPUT S ;"IN"
40 ENTER S ; A$
50 DISP "FREQUENCY A =" ;A$[2]
60 GOTO 30
70 END

```

PROGRAM DESCRIPTION

- Line 10 Remarks; comments only, does not affect the program.
- Line 20 Set "S" equal to 703.
- Line 30 Output "IN" command to HP 5384A/HP 5385A at address "S".
- Line 40 Read HP 5384A/HP 5385A response into "A\$".
- Line 50 Display "Frequency A="; followed by the contents of the second character onward of "A\$".
- Line 60 Go to line 30.
- Line 70 End program execution.

EXAMPLE 4. REMOTE DISPLAY

The following example demonstrates how to send messages to the display of the counter. The program sets the address to 03 then sends a message to the display of the counter.

PROGRAM

```

10 REM      Example #4   REMOTE DISPLAY     "TAR4"
20 S=703
30 OUTPUT S ;"DR  HP 5384A"
40 END

```

PROGRAM DESCRIPTION

- Line 10 Remarks; comments only, does not affect the program.
- Line 20 Set "S" equal to 703.
- Line 30 Send remote display message (HP 5384A/HP 5385A) to instrument at address "S".
- Line 40 End program execution.

EXAMPLE 5. FREQUENCY A MEASUREMENT

The following example demonstrates how to display a Frequency A measurement on the display (X register) of the HP-41C/CV. Included in the example are the keystrokes required to program the HP-41C/CV.

The following program initializes the counter (locates the counter in the loop and sets the counter to Remode mode). After initialization, the program sends instructions to measure the frequency at Input A, set up a gate time of one second, enable the 100 kHz Low Pass Filter, and send the measurement back to the display of the HP-41C/CV.

For the example, use the set-up shown in *Figure 3-12, Example 5 Set-Up*, and make the following adjustments.

1. Set a signal generator to a sine wave frequency of $500\text{ kHz} \pm 10\text{ kHz}$.
2. Set an output level of $250\text{ mV} \pm 100\text{ mV}$.
3. Connect the signal generator to Input A of the HP 5384A/HP 5385A.
4. Cycle the HP 5384A/HP 5385A counter from STBY to ON.
5. Press the INPUT B key.

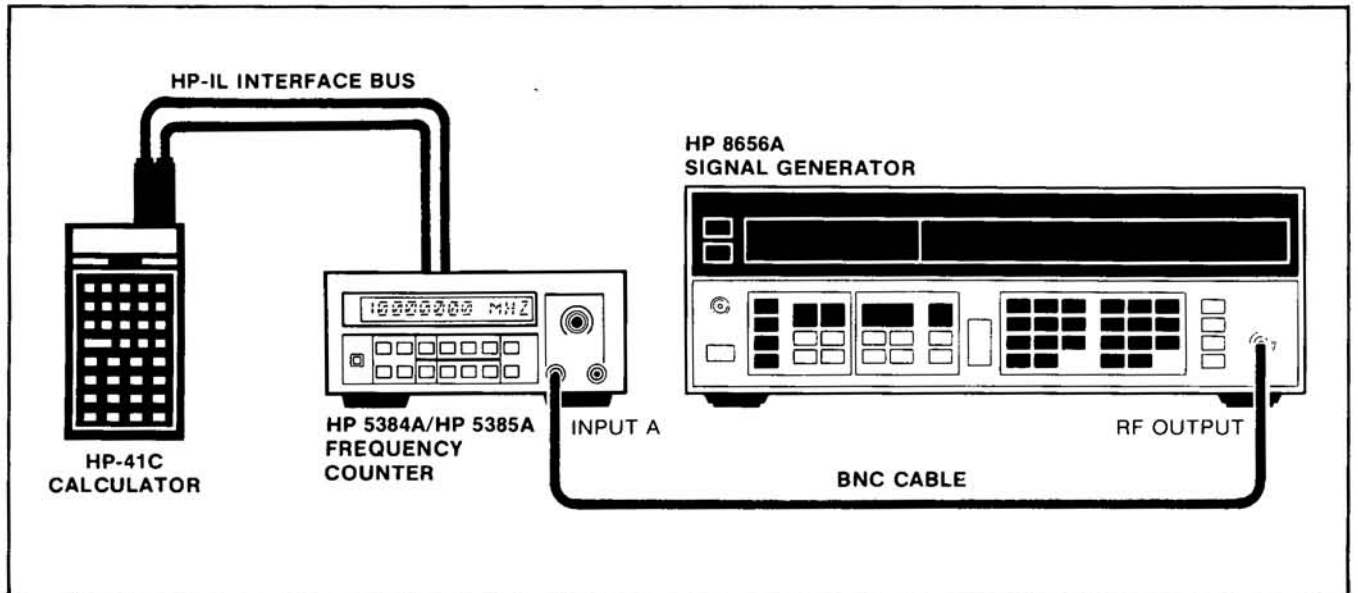

Figure 3-12. Example 5 Set-Up

Use the following keystrokes to:

1. Program the HP-41C/CV to perform the Frequency A measurement.
2. Execute the program.

NOTE: Clear Memory First.

HP 41C/CV

HP 41C/CV DISPLAY

1. PRGM
2. GTO
3. LBL ALPHA IN 1 8 4 ALPHA
4. XEQ ALPHA IND ALPHA
5. CF 17
6. ALPHA HP 5 3 8 4
7. XEQ ALPHA FINDID ALPHA
8. ALPHA FU 1 GA 2 FI 1
9. XEQ ALPHA OUTA ALPHA
10. XEQ ALPHA IND ALPHA
11. GTO
12. PRGM
13. ASN ALPHA IN 1 8 4 ALPHA
14. LN
15. USER
16. LN

00	REG	46	PRGM
00	REG	46	PRGM
01	LBL	TIN	184
02	XEQ	TAUTO	ID
03	CF	17	PRGM
04	T	HP5384A	PRGM
05	XEQ	T	FINDID
06	T	FU1GA2FI	1
07	XEQ	T	OUTA
08	XEQ	T	IND
00	REG	38	PRGM
00000			
ASN	IN	184	-
ASN	IN	184	15
0.0000			
0.0000			
USER			
USER			PRGM

NOTE: All shaded keys represent the gold shift key on the HP 41C/CV.

PROGRAM DESCRIPTION





































































- Step 1 The program (PRGM) key places the HP 41C/CV into the programming mode. Keystrokes are recorded as programming instructions. The PRGM annunciator appears in the display.
- Step 2 The GTO key places the HP 41C/CV at the end of program memory and inserts the END instruction if it is not present. The HP 41C/CV displays the number of registers left in program memory.
- Step 3 The Label (LBL) key labels the program with the name "IN184". The ALPHA key toggles the HP 41C/CV into and out of ALPHA mode to enter letters in the program name. Press the gold shift key before keying each number.
- Step 4 The Execute (XEQ) command followed by the Auto input/output (AUTOIO) command, sets up the loop so the interface automatically searches for the proper device to carry out the operations of the program.
- Step 5 Flag 17 is cleared. Flag 17 controls how the HP-IL module uses the standard end-of-line indicator; Carriage Return (CR) and Line Feed (LF).
- Step 6 The name of the device the interface will search for is entered here.
- Step 7 The Execute (XEQ) command followed by the Find Identity (FINDID) command causes the interface to search for the HP 5384A and determine the address of the device on the loop.
- Step 8 The command codes that cause the counter to make the Frequency A measurement, set the gate time to one second and enable the 100 KHz low pass filter are entered into the ALPHA register.
- Step 9 The Execute (XEQ) command followed by the Output A (OUTA) command causes the contents of the ALPHA register to be sent to the counter.
- Step 10 The Execute (XEQ) command followed by the Input Decimal (IND) command causes the counter display (X register) of the HP 41C/CV.
- Step 11 The GTO command places an END statement at the end of the program. The display will show how many registers are left in program memory.
- Step 12 The program (PRGM) key toggles the HP 41C/CV out of the program mode.
- Step 13 The Assign (ASN) key will assign the program "IN184" to a key location on the HP 41C/CV keyboard.
- Step 14 The LN key is the key location selected for the program "IN184". The assigned key location 1, 5, (Row 1, Column 5) is briefly displayed at the right side of the display.
- Step 15 The USER key toggles the HP 41C/CV into the USER mode for access to the programs called up by the various key locations.
- Step 16 The LN key in the USER mode executes the program "IN184". Program execution is indicated by a  symbol moving across the display from left to right.

Table 3-10. LCD Character Set

LCD CHAR.	ASCII CHAR.	DECIMAL	LCD CHAR.	ASCII CHAR.	DECIMAL	LCD CHAR.	ASCII CHAR.	DECIMAL
	NULL, @	0, 64		SYNC, V	22, 86		,	44
	SOH, A	1, 65		ETB, W	23, 87		—, m	45, 109
	STX, B	2, 66		CAN, X	24, 88		.	46,
	EXT, C	3, 67		EM, Y	25, 89		/, o	47, 111
	EOT, D	4, 68		SUB, Z	26, 90		0, p	48, 112
	ENQ, E	5, 69		ESC,	27, 91		1, q	49, 113
	ACK, F	6, 70		FS, \	28, 92		2, r	50, 114
	BELL, G	7, 71		GS,	29, 93		3, s	51, 115
	BS, H	8, 72		RS, ^	30, 94		4, t	52, 116
	HT, I	9, 73		US, _	31, 95		5, u	53, 117
	LF, J	10, 74		space, `	32, 96		6, v	54, 118
	VT, K	11, 75		!, a	33, 97		7, w	55, 119
	FF, L	12, 76		", b	34, 98		8, x	56, 120
	CR, M	13, 77		#, c	35, 99		9, y	57, 121
	SO, N	14, 78		\$, d	36, 100		z	122
	SI, O	15, 79		%, e	37, 101		:	58, 122
	DLE, P	16, 80		&, f	38, 102		;	59, 123
	DC1, Q	17, 81		', g	39, 103		<,	60, 124
	DC2, R	18, 82		(, h	40, 104		=, }	61, 125
	DC3, S	19, 83	), i	41, 105		>, ~	62, 126
	DC4, T	20, 84		*, j	42, 106		?, DEL	63, 127
	NAK, U	21, 85		+, k	43, 107		l	108
							n	110

SECTION IV PERFORMANCE TESTING

4-1. INTRODUCTION

4-2. The procedures in this section provide two types of tests. First, a complete performance test for the HP 5384A and HP 5385A Frequency Counters. They can be performed without access to the interior of the instrument. The second test is an HP-IB verification test using the HP85A controller.

4-3. EQUIPMENT REQUIRED

4-4. Equipment required for complete test and operation verification is listed in *Table 1-2*. Any equipment which satisfies the critical specifications given in the table may be substituted for the recommended model numbers.

4-5. TEST RECORD

4-6. Results of the complete performance test should be recorded on a copy of the Performance Test Card at the end of this section.

4-7. ERROR MESSAGES

4-8. Under certain conditions the counter will display Error messages. Error messages typically occur during the power-up, initialize cycle. These messages indicate a hardware failure or the user has attempted an improper operation, either through the keyboard or the interface.

4-9. Performance Test

4-10. The performance test is given in *Table 4-1*. The performance test verifies all specifications listed in *Table 1-1*. All tests can be performed without access to the interior of the instrument.

Table 4-1. Performance Test

I. POWER-UP CHECK

Description:

The HP 5384A/HP 5385A Frequency Counter power is set to STBY, then on. The counter will be cycled through its power-up, initialize subroutine. This test is performed with no external time base signal applied to the counter. A test is made of all the major function blocks, then goes to its initialize state.

a. Set-up:

Insure that no cables are connected to input A or to the interface connector. Cycle the POWER switch from STBY to ON.

b. Verify the following:

1. A display "starburst" is shown in all 12-character positions for about one second.
2. The selected address of the instrument interface is displayed for about one second.
3. The display shows "00000000" and an arrow appears over the "A" for "A" channel.

c. Record the result on the test card (Pass/Fail).

II. CHANNEL A FREQUENCY RESPONSE AND SENSITIVITY TEST (HP 5384A/HP 5385A)

Description:

A signal generator with a calibrated output is set to the specified HP 5384A/HP 5385A channel A minimum signal sensitivity level. The frequency is slowly increased from 10 Hz up to 20 MHz at a constant level. The HP 5384A/HP 5385A reading is checked for the proper count. For the range of 20 MHz to 100 MHz, a different generator is used.

Table 4-1. Performance Test (Continued)

Specifications: 10 Hz to 100 MHz:

25 mV rms, sinewave, 10 Hz to 50 Hz

15 mV rms, sinewave, 50 Hz to 100 MHz

a. 10 Hz to 50 Hz:

1. Connect the HP 3325A synthesizer/function generator to HP 5384A/HP 5385A A channel input as shown in Figure 4-1.

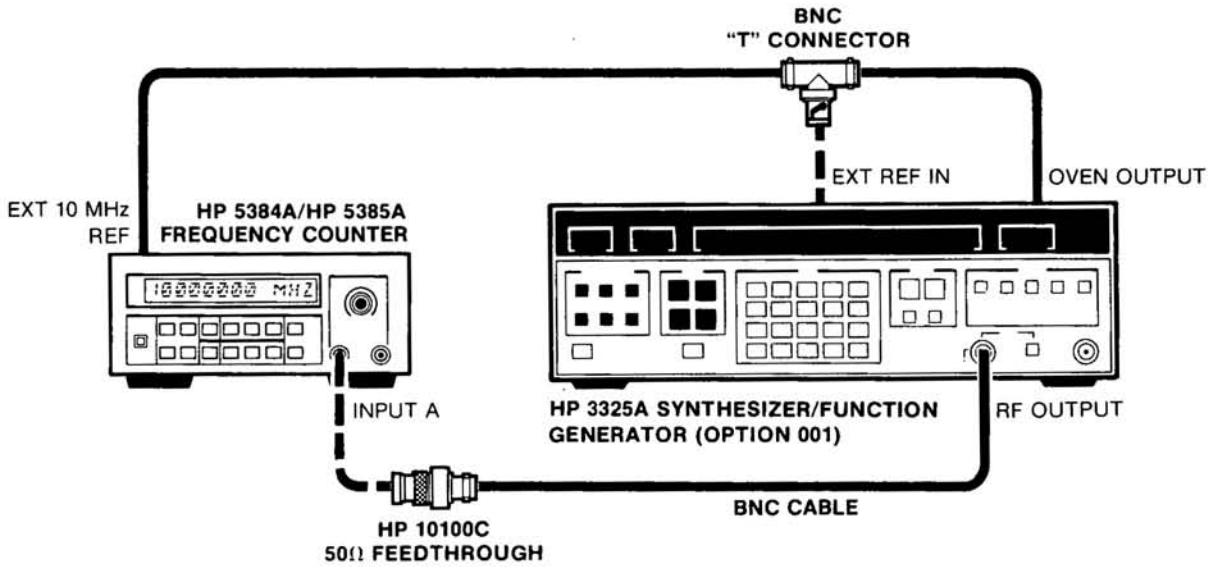

Figure 4-1. Channel A Frequency Response and Sensitivity Test Setup (HP 5384A/HP 5385A)

2. Set the HP 3325A to output a 10 Hz sinewave at 25 mV rms. Increase the frequency of the HP 3325A and verify the HP 5384A/HP 5385A displays the proper frequency from 10 Hz to 50 Hz. Record the results on the test card (Pass/Fail).
- b. 50 Hz to 20 MHz
1. Use the same set-up shown in Figure 4-1.
 2. Set the HP 3325A to output a 50 Hz sinewave at 15 mV rms. Increase the frequency of the HP 3325A and verify the HP 5384A/HP 5385A displays the proper frequency from 50 Hz to 20 MHz. Record the results on the test card (Pass/Fail).
- c. 20 MHz to 100 MHz
1. Connect the HP 8656A Signal Generator to the HP 5384A/HP 5385A A channel input as shown in Figure 4-2.

Table 4-1. Performance Test (Continued)

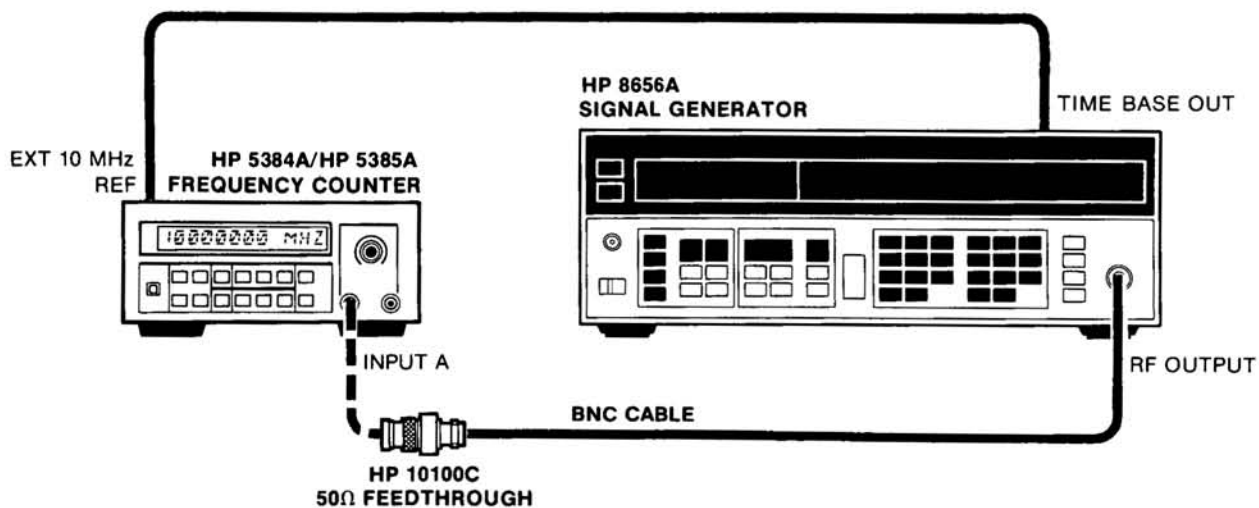

Figure 4-2. Channel A Frequency Response and Sensitivity Test Setup for HP 5384A/HP 5385A

2. Set the HP 8656A to output a 20 MHz sinewave at 15 mV rms. Increase the frequency of the HP 8656A and verify the counter displays the proper frequency from 20 MHz to 100 MHz. Record the results on the test card (Pass/Fail).

III. CHANNEL B FREQUENCY RESPONSE AND SENSITIVITY TEST FOR HP 5384A

Description:

A signal generator with a calibrated output is set to the specified HP 5384A channel B minimum signal sensitivity level. The frequency is slowly increased from 50 MHz up to 225 MHz at a constant level, and the HP 5384A reading is checked for the proper count.

Specifications: 50 MHz to 225 MHz:

- 10 mV rms, sinewave, 50 MHz to 200 MHz
- 15 mV rms, sinewave, 200 MHz to 225 MHz

a. 50 MHz to 200 MHz

1. Connect the HP 8656A signal generator to the HP 5384A B channel input as shown in Figure 4-3.

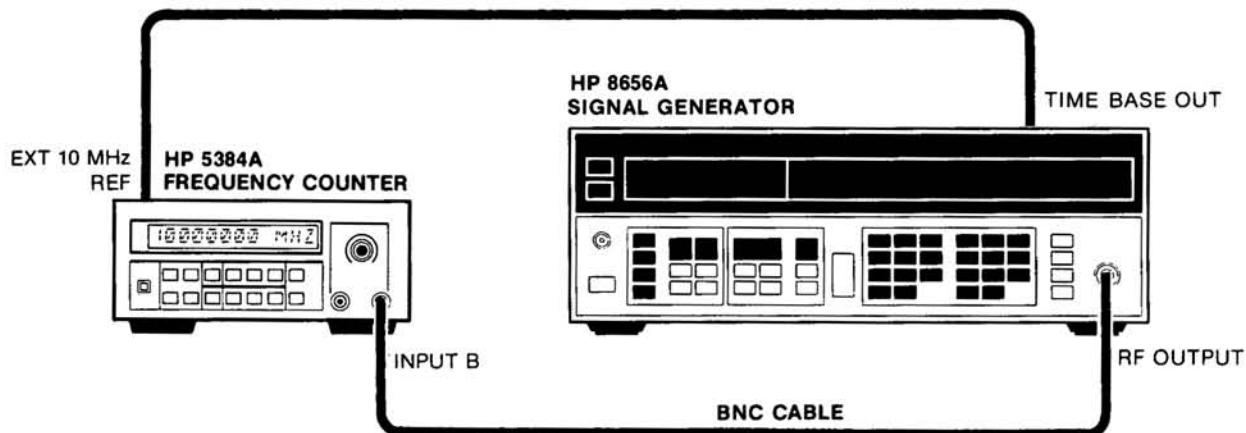

Figure 4-3. Channel B Frequency Resonse and Sensitivity Test Setup for HP 5384A

Table 4-1. Performance Test (Continued)

2. Set the HP 8656A to output a 50 MHz sinewave at 10 mV rms. Select frequency B on the HP 5384A. Increase the frequency of the HP 8656A and verify that the HP 5386A displays the proper frequency from 50 MHz to 200 MHz. Record the results on the test card (Pass/Fail).
- b. 200 MHz to 225 MHz
1. Set the HP 8656A to output a 200 MHz sinewave at 15 mV rms. Increase the frequency of the HP 8656A and verify that the HP 5384A displays the proper frequency from 200 MHz to 225 MHz. Record the results on the test card (Pass/Fail).

IV. CHANNEL B FREQUENCY RESPONSE AND SENSITIVITY TEST FOR HP 5385A

Description:

A signal generator is connected through a power splitter to the HP 5385A channel B input and to a power meter. The signal generator is varied over the frequency range, maintaining the specified signal level. The counter should display the correct frequencies.

Specifications:

- 15 mV rms (-23.5 dBm) sinewave, 90 MHz to 100 MHz
- 10 mV rms (-27 dBm) sine wave, 100 MHz to 1000 MHz

- a. 90 MHz to 100 MHz
1. Connect the signal generator and the power meter to the HP 5385A channel B input as shown in Figure 4-4.

NOTE

There shall be no cabling between the HP 11667A Power Splitter and the HP 5385A channel B input or between the power splitter and the power sensor.

VOLTAGE	dBm EQUIVALENT
6.5 mV	-30.73 dBm
7.0 mV	-30.09 dBm
8.0 mV	-28.93 dBm
9.0 mV	-27.90 dBm
10.0 mV	-26.99 dBm
12.0 mV	-25.41 dBm
15.0 mV	-23.47 dBm

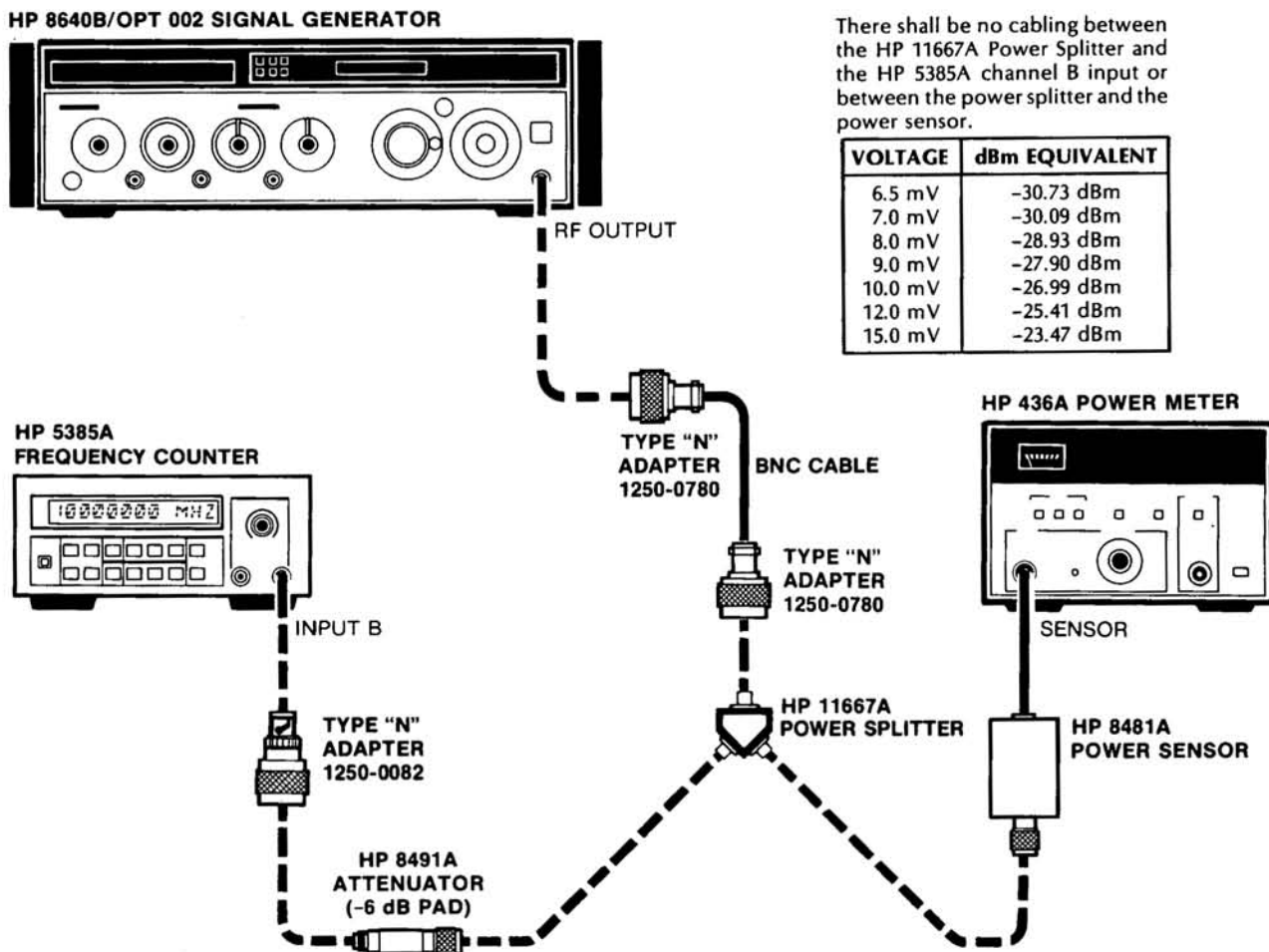

Figure 4-4. Channel B Frequency Response and Sensitivity Test Setup for HP 5385A

Table 4-1. Performance Test (Continued)

2. Set the HP 8640B Signal Generator so the HP 436A Power Meter reads -17.5 dBm at 90 MHz. Increase the frequency of the signal generator while maintaining a -17.5 dBm reading on the power meter. Verify the HP 5385A displays an increase in frequency, approximately tracking the signal generator from 90 MHz to 100 MHz. Record the results on the test card (Pass/Fail).
- b. 100 MHz to 1000 MHz
1. Set the HP 8640B Signal Generator so the power meter reads -21 dBm at 100 MHz. Increase the frequency of the signal generator while maintaining a -21 dBm reading on the power meter, and verify the HP 5385A displays the proper frequencies from 100 MHz to 1000 MHz. Record the results on the test card (Pass/Fail).

V. PERIOD A TEST

Description:

A signal generator with a calibrated output drives channel A of the HP 5384A/HP 5385A under test. The counter is set to measure the period of the signal. The HP 5384A/HP 5385A should display the proper count.

Specifications: 10 nanoseconds to 0.1 seconds (100 MHz to 10 Hz)

- a. Connect the HP 3325A synthesizer/function generator to the HP 5384A/HP 5385A Channel A input as shown in Figure 4-5.

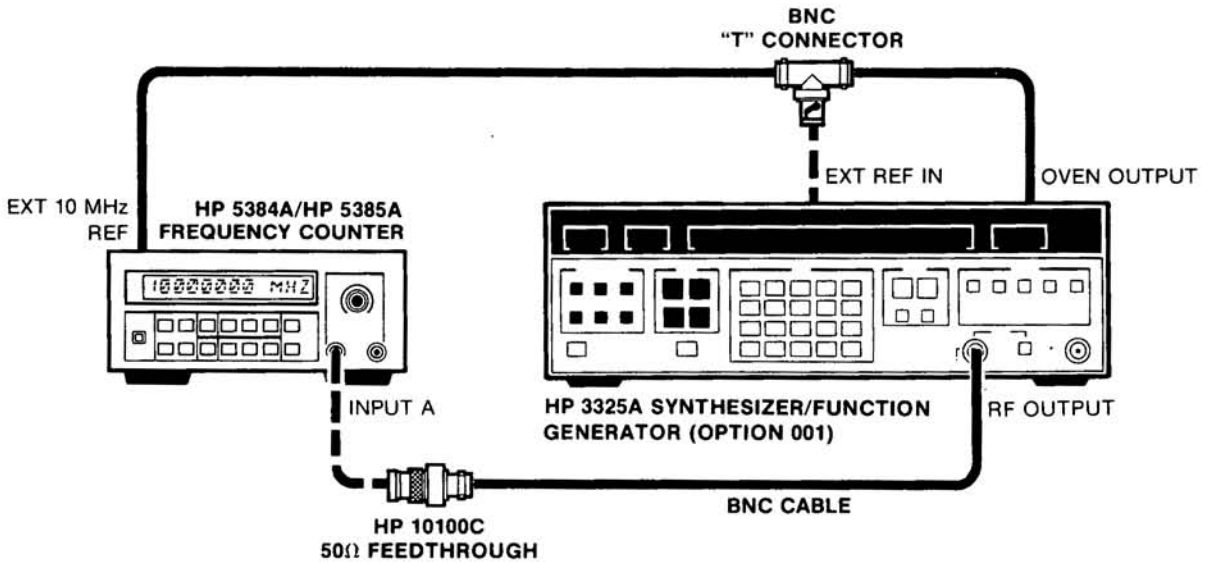

Figure 4-5. Period A Test Setup

- b. Set the counter power switch from STBY to ON and select PERIOD A. Set the GATE time to 1.0 seconds.
- c. Set the HP 3325A synthesizer to 10 Hz at 100 mV rms output.
- d. Verify the counter displays 100.00000 milliseconds ± 70 microseconds. Record the results on the test card (pass/fail).

VI. CHANNEL A FILTER AND ATTENUATOR TEST

Description:

A signal generator with a calibrated output drives the channel A of the HP 5384A or HP 5385A under test. The counter is set up for its Frequency A function, and the channel A filter is exercised at frequencies below and above its normal 3 dB point. The channel A attenuator is also exercised. The counter should display the proper frequencies.

Table 4-1. Performance Test (Continued)

Specifications:

Low Pass Filter, 100 kHz, nominal at 3 dB point.
X1 or X20, nominal, selectable.

Perform the following steps to use the Channel A Filter and Attenuator tests.

- a. Set the counter POWER switch from STBY to ON; set the gate time to 1.0 seconds.
- b. Connect the HP 3325A Synthesizer/Function Generator to the HP 5384A/HP 5385A Channel A input as shown in Figure 4-6.

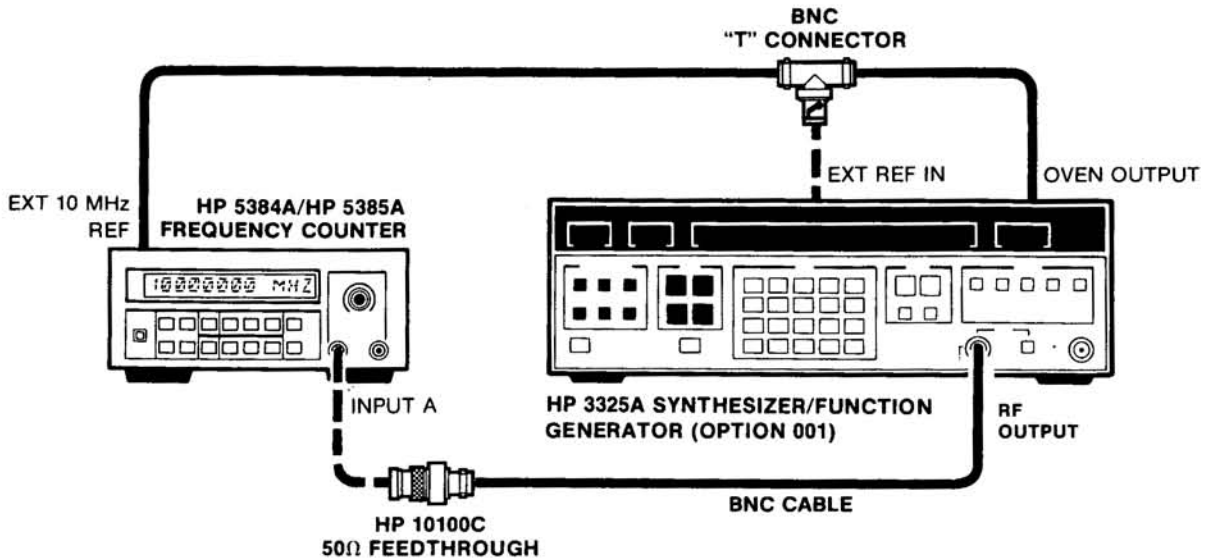

Figure 4-6. Channel A Filter and Attenuator Test Setup

- c. Press the 1 second gate time Key.
- d.
 1. Set the HP 3325A to output a 50 kHz sinewave at 15 mV rms.
 2. Verify that the counter displays 50.0000000K ± 3 millihertz, with a continuous indication above "A" and a flashing indicator above "GATE" on the front panel.
 3. Enable the channel A FILTER function; observe that the HP 5384A/HP 5385A display has not changed and an indicator arrow appears in the display above the "FILT" label on the front panel.
 4. Disable the FILTER function.
- e.
 1. Set the HP 3325A to output a 1 MHz sinewave at 55 mV rms.
 2. Verify counter displays "1.00000000M" ± 10 millihertz
 3. Enable the channel A FILTER function; observe that the counter displays all zeros.
 4. Disable the FILTER function and observe that the counter displays 1.00000000 MHz ± 10 millihertz.
 5. Record the results on the test card (Pass/Fail).
- f.
 1. Enable the channel A X20 ATTENUATOR; observe the HP 5384A/HP 5385A display showing eight zeros with indicators above "ATTN" and "A" only. Disable the X20 ATTN function, and observe the counter displaying the same value as in step e. Record the results on the test card (pass/fail).

PERFORMANCE TEST RECORD

HEWLETT-PACKARD MODEL 5384A/5385A FREQUENCY COUNTER		Repair/Work Order No. _____
Serial Number: _____		Temperature: _____
Test Performed By: _____		Relative Humidity: _____
Date: _____		Post Calibration Test: <input type="checkbox"/>
Notes: _____		Pre Calibration Test: <input type="checkbox"/>

PARA. NO.	TEST	CORRECT DISPLAY	RESULTS		
			YES	NO	
I.	POWER-UP SELF CHECK "Starburst" Displayed All Positions Selected Address Displayed 8 Zeroes Arrow Over "A" Channel Displayed	"Starburst" "SELECTED ADDRESS" 00000000 Δ	_____	_____	
			_____	_____	
			_____	_____	
			_____	_____	
II.	CHANNEL A FREQUENCY RESPONSE AND SENSITIVITY TEST (HP 5384A/85A) 10 Hz - 50 Hz @ 25 mV rms 50 Hz - 20 MHz @ 15 mV rms 20 MHz - 100 MHz @ 15 mV rms	Stable Count Stable Count Stable Count	_____	_____	
			_____	_____	
			_____	_____	
			_____	_____	
III.	CHANNEL B FREQUENCY RESPONSE AND SENSITIVITY TEST (HP 5384A) 50 MHz - 200 MHz @ 10 mV rms 200 MHz - 225 MHz @ 15 mV rms	Stable Count Stable Count	_____	_____	
			_____	_____	
			_____	_____	
			_____	_____	
IV.	CHANNEL B FREQUENCY RESPONSE AND SENSITIVITY TEST (HP 5385A) Display, 90 MHz - 100 MHz @ -17.5 dBm 100 MHz - 1000 MHz @ -21 dBm	Stable Count Stable Count	_____	_____	
			_____	_____	
			_____	_____	
			_____	_____	
V.	PERIOD A TEST Counter Displays 100.00000 milliseconds		MINIMUM	ACTUAL	MAXIMUM
		99.93000	_____	_____	100.07000
			YES	NO	
VI.	CHANNEL A FILTER AND ATTENUATOR TEST FILTER Off Enable FILTER FILTER Off Enable FILTER — Counter Displays All Zeroes Disable FILTER Enable X20 ATTENUATOR Counter Displays all zeroes	50.0000000 K Δ Flashing Arrow above GATE 1.00000000 M 00000000 1.00000000 M 00000000	_____	_____	
			_____	_____	
			_____	_____	
			_____	_____	
			_____	_____	
			_____	_____	
			_____	_____	
			_____	_____	

SECTION V ADJUSTMENTS

5-1. INTRODUCTION

5-2. This section describes the adjustments required to maintain the HP 5384A/HP 5385A operating characteristics within specifications. Adjustments should be made when required, such as after a performance test failure or when components are replaced that may affect an adjustment.

5-3. *Table 5-1* lists the adjustment procedures, in the recommended order of performance, and indicates the adjustable components involved.

5-4. EQUIPMENT REQUIRED

5-5. The test equipment required for the adjustment procedures is listed in *Table 1-4*, Recommended Test Equipment. Substitute instruments may be used if they meet the critical specifications.

5-6. ADJUSTMENT LOCATIONS

5-7. Adjustment locations are identified in the procedure for each adjustment.

5-8. SAFETY CONSIDERATIONS

5-9. This section contains warnings that must be followed for your protection and to avoid damage to the instrument.

WARNING

MAINTENANCE DESCRIBED HEREIN IS PERFORMED WITH POWER SUPPLIED TO THE INSTRUMENT AND PROTECTIVE COVERS REMOVED. SUCH MAINTENANCE SHOULD BE PERFORMED ONLY BY SERVICE-TRAINED PERSONNEL WHO ARE AWARE OF THE HAZARDS INVOLVED (FOR EXAMPLE, FIRE AND ELECTRICAL SHOCK), WHERE MAINTENANCE CAN BE PERFORMED WITHOUT POWER APPLIED, SHOULD BE REMOVED.

BEFORE ANY REPAIR IS COMPLETED, ENSURE THAT ALL SAFETY FEATURES ARE INTACT AND FUNCTIONING, AND THAT ALL NECESSARY PARTS ARE CONNECTED TO THEIR PROTECTIVE GROUNDING MEANS.

Table 5-1. Adjustments

ASSEMBLY	ADJUSTMENT	COMMENTS
A1 Motherboard	A1R77	HP 5384A/HP 5385A +3 Vdc Adjustment
A1 Motherboard	A1R43	HP 5384A/HP 5385A Channel A Input Amplifier Adjustment
A1 Motherboard	A1R32	HP 5384A Channel B Input Amplifier Adjustment
A1 Motherboard	A1R34	HP 5385A Channel B Input Amplifier Adjustment
A1 Motherboard	A1C65 A1C66	Standard Oscillator Adjustment
A1 Motherboard	Y1B	2 TCXO Oscillator Adjustment
A1 Motherboard	Y1A	Oven Oscillator Adjustment
A3 Battery Chg	A3R26	Fast Charge Threshold Adjustment
A3 Battery Chg	A3R25	Fast Charge Current Adjustment

5-10. HP 5384A/HP 5385A ADJUSTMENT PROCEDURES

5-11. HP 5384A/HP 5385A +3 Volt dc Adjustment Procedure

5-12. The only voltage supply in the HP 5384A and HP 5385A that requires adjustment is the +3 Volts. To perform this adjustment, proceed as follows:

- a. Switch the counter from STBY to ON.
- b. Connect the positive terminal of the DVM to TP1 and the negative terminal to chassis ground at the ac input power connector in the rear of the counter.
- c. Adjust A1R77 for a DVM reading of 3.00 Volts, ± 30 mV.
- d. Switch the counter from ON to STBY. Disconnect the test equipment.

5-13. HP 5384A/HP 5385A Channel A Input Amplifier Adjustment Procedure

5-14. To perform the sensitivity adjustment, proceed as follows:

a. Remove the HP 5384A/HP 5385A top and bottom covers; locate variable resistor A1R43 as shown in *Figure 5-1*, Assembly Adjustment Locator.

b. Cycle the power switch from STBY to ON. Allow 30 minutes warm-up time.

c. Connect the HP 8656A Signal Generator as shown in *Figure 5-2*.

d. Set the HP 8656A to output a 10 MHz sinewave at 10 mV rms.

e. Connect the scope probe at the junction of A1R19 and A1R65E. See *Figure 5-1* for probe connection point.

f. Adjust A1R43 for a 50/50 duty cycle. Refer to the waveform in *Figure 5-3*.

g. Vary the frequency of the signal generator from 10 MHz to 100 MHz, and verify that the counter shows a stable display throughout.

h. Connect a suitable generator (such as the HP 3325A) to input A that can provide a 25 mV rms sine wave between 10 Hz and 50 Hz. Vary the generator frequency between 10 Hz and 50 Hz and verify that the displayed counts are stable.

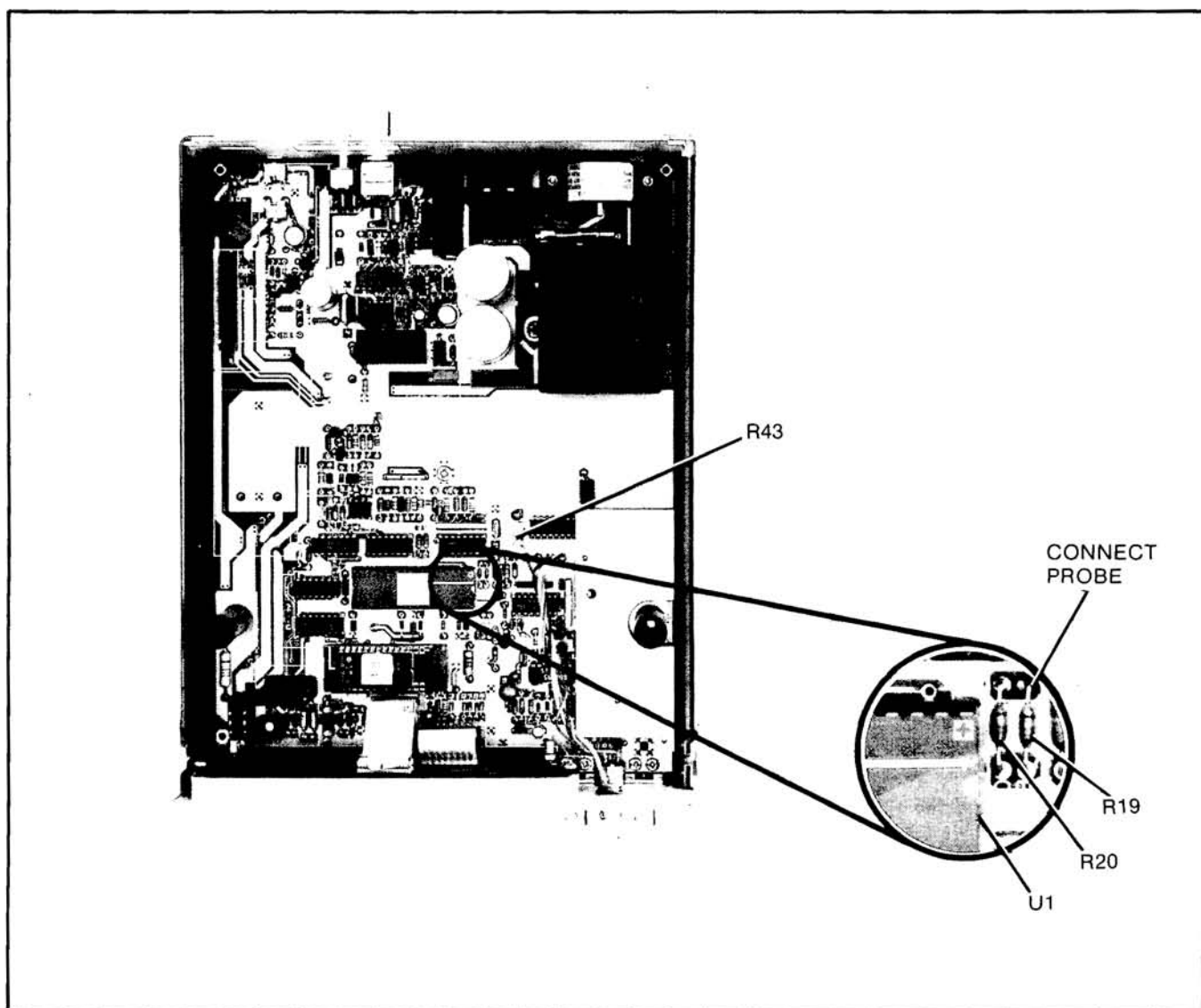

Figure 5-1. Assembly Adjustment Locator

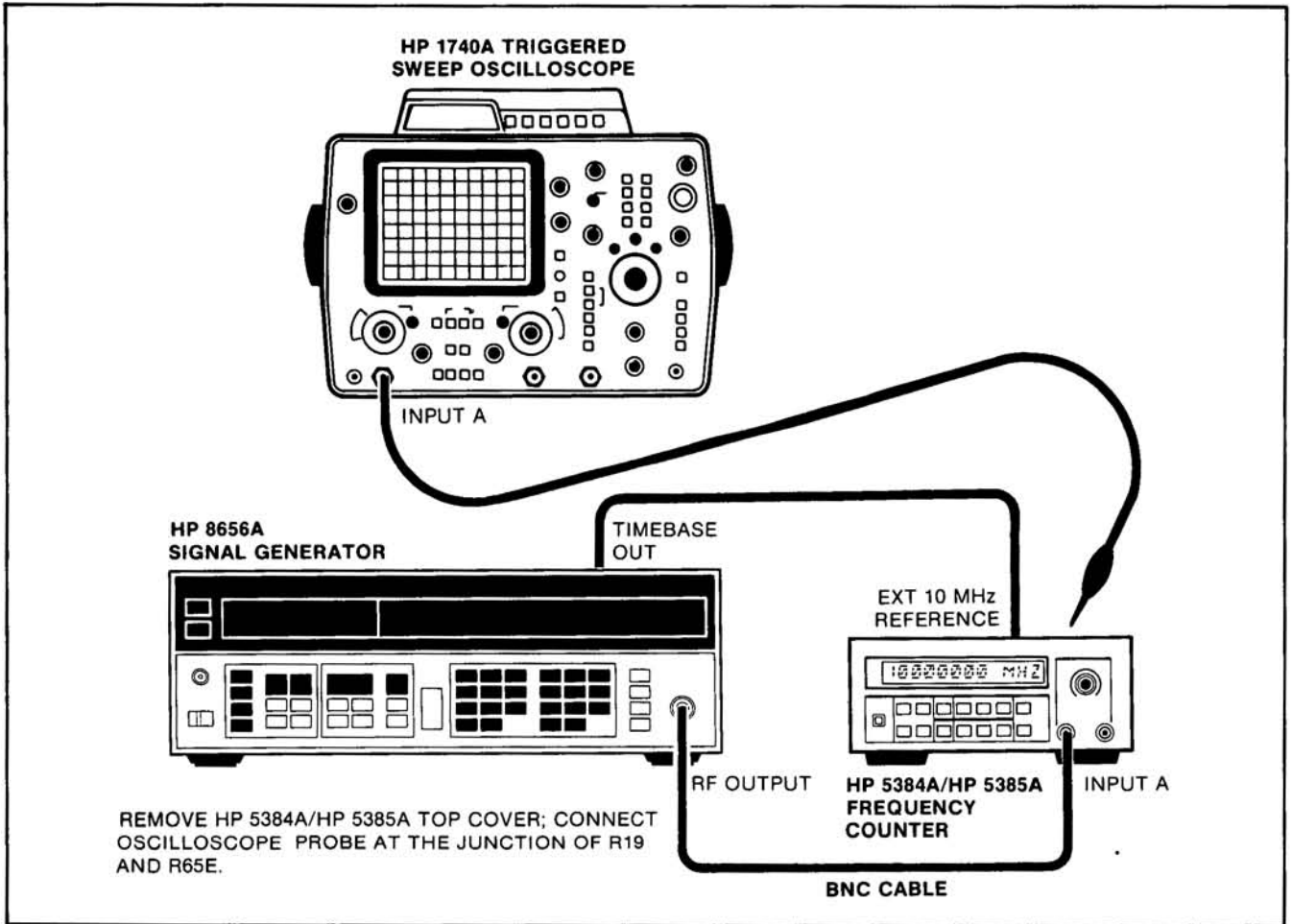

Figure 5-2. Channel A Input Amplifier Adjustment Setup

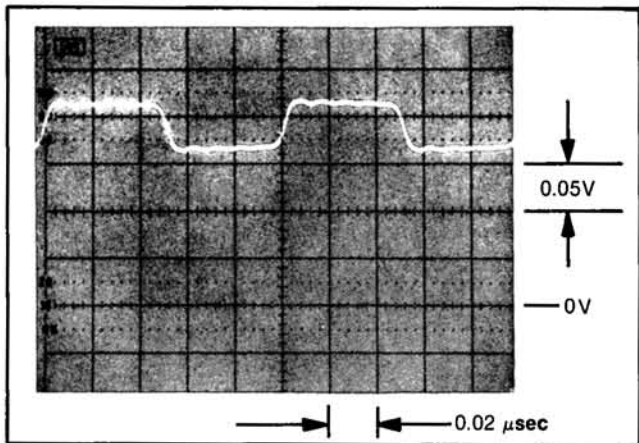

Figure 5-3. Input Amplifier Adjustment Waveform

5-15. HP 5384A Channel B Input Amplifier Adjustment Procedure

5-16. To perform the sensitivity adjustment proceed as follows:

- a. Connect the HP 8656A Signal Generator as shown in Figure 5-4.

- b. Cycle the power switch from STBY to ON and press the **FREQ B** button on the HP 5384A front panel.
- c. Set the HP 8656A to output a 200 MHz sinewave at 6 mV rms. Adjust A1R32 for a stable display count. Vary the frequency from 200 MHz to 50 MHz and verify that the counter shows a stable display.
- d. This completes the adjustment for Channels A and B; switch the counter to STBY and disconnect all test equipment.

5-17. HP 5385A Channel B Input Amplifier Adjustment Procedure

5-18. To perform the sensitivity adjustments, proceed as follows:

- a. Cycle the power switch from STBY to ON. Press **FREQ B** button on the front panel.
- b. Locate variable resistor A1R34 on the A1 Motherboard. Refer to the A1 component locator in Section VIII.
- c. Connect instruments as shown in Figure 5-5.

HP 5384A and HP 5385A
Adjustments

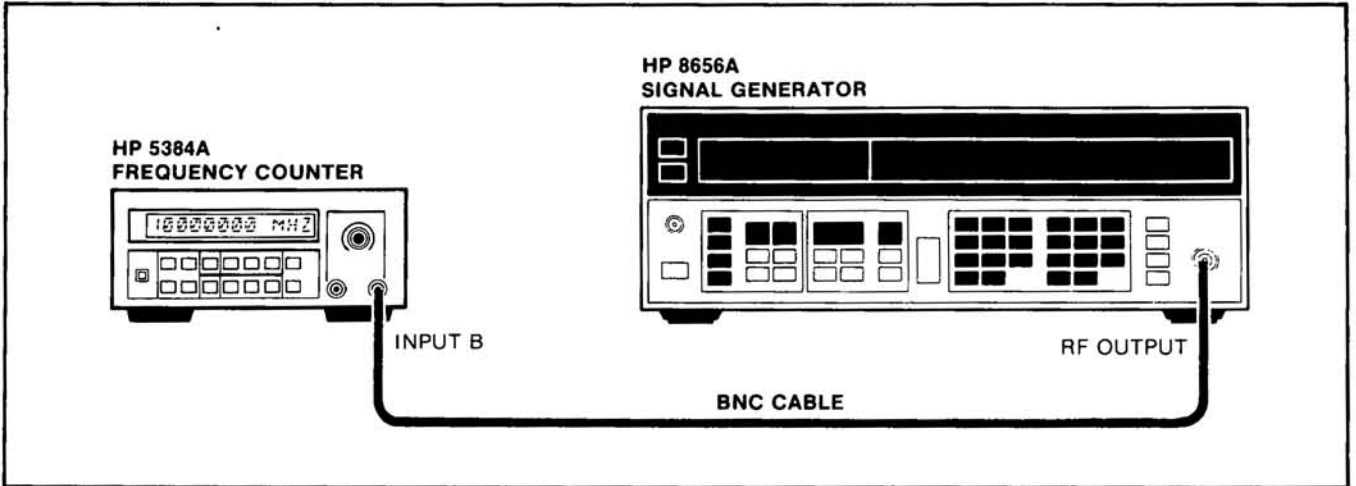

Figure 5-4. HP 5384A Channel B Input Amplifier Adjustment Setup

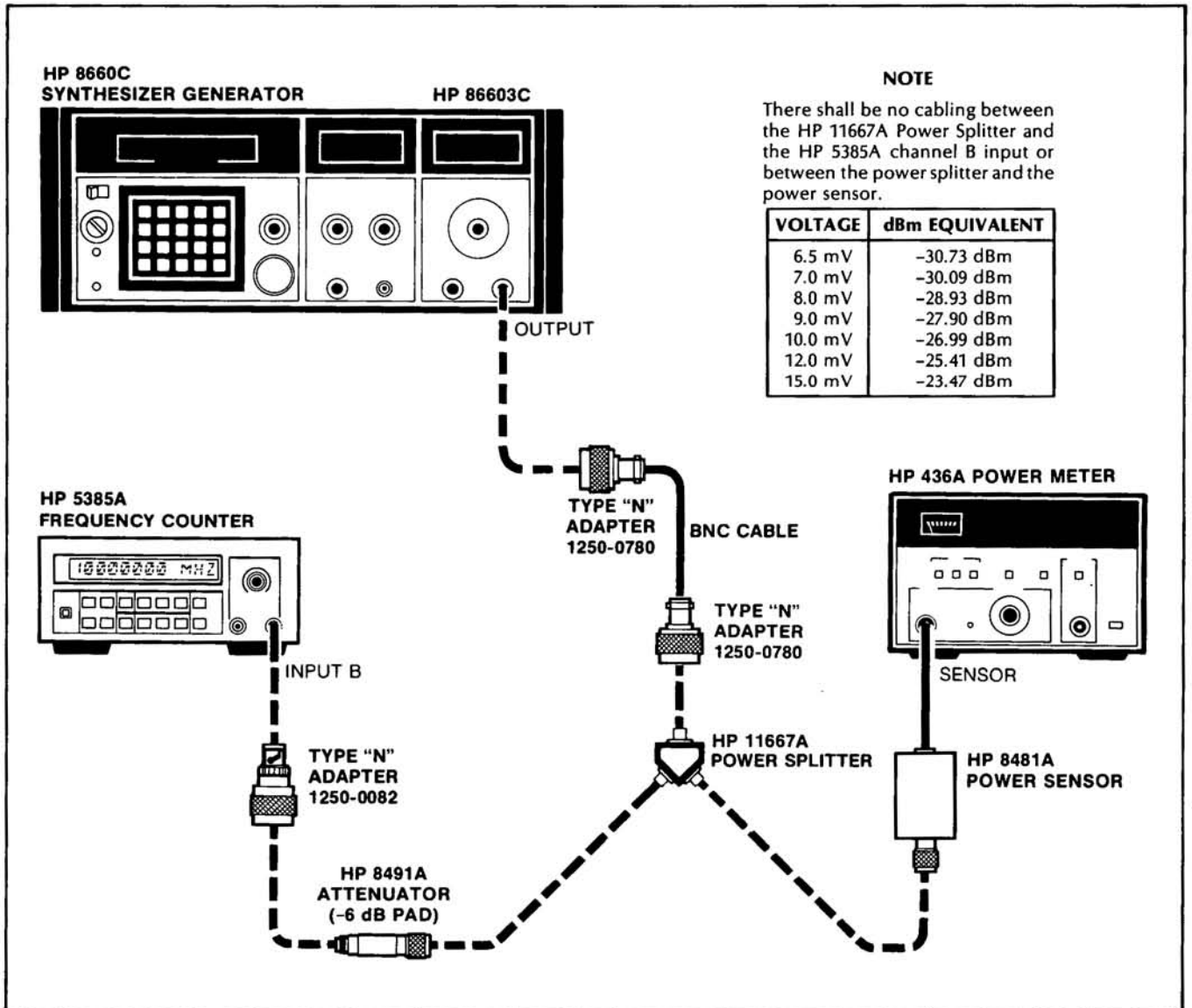

Figure 5-5. HP 5385A Channel B Input Amplifier Adjustment Setup

- d. Set HP 8660C to output a 100 MHz sinewave, varying the HP 86603A vernier until the HP 436A power Meter reads -24 dBm , $\pm 0.3 \text{ dBm}$. Adjust A1R34 for a stable display of 100.00000 MHz , $\pm 10 \text{ Hz}$.
- e. Vary the frequency range from 90 MHz to 1000 MHz and verify the HP 5385A displays the correct count.
- f. Turn the HP 5385A and the HP 8660C off and disconnect all test equipment.

5-19. Standard Oscillator Adjustment Procedures

5-20. The procedure used for adjusting the standard oscillator is the same as the procedure used for adjusting the TCXO at 25°C described in paragraph 5-23. Refer to paragraph 5-23 for adjustment procedure.

5-21. TCXO Adjustment Procedure

5-22. Two procedures are given for the adjustment of the TCXO (Temperature compensated Crystal Oscillator). If the operation of the counter will be solely at 25°C (77°F), then adjust the oscillator frequency as close as possible to 10 MHz using the procedure in paragraph 5-23. If the operation of the counter will be over the full temperature range (0°C to 40°C) then the TCXO must be offset by the amount

labeled on its cover to keep the TCXO frequency within the manufacturers frequency specifications over the temperature range of 0°C to 40°C. In this case use the procedure in paragraph 5-28. The TCXO is factory set for use near 25°C.

5-23. Adjustment of the TCXO at 25°C

NOTE

Allow 30 minutes warm-up time for the counter.

- a. Connect a house standard (reference frequency) to the EXT TRIGGER input of an HP 1740A Oscilloscope as shown in Figure 5-6. Set the HP 1740A oscilloscope to EXT (trigger).
- b. Connect the HP 5384A/HP 5385A rear panel 10 MHz REFERENCE IN OUT to the channel A input of the HP 1740A oscilloscope as shown in Figure 5-6.
- c. Select INT with the 10 MHz REFERENCE INT EXT select switch on the rear of the instrument (see Figure 5-7).
- d. Adjust the frequency for minimum sideways movement of the 10 MHz signal with the OSC ADJ located on the rear of the instrument (see Figure 5-7). For the Standard Oscillator, the same rear panel location is used to adjust A1C66, the standard oscillator fine adjustment capacitor. If A1C66 does not have enough range to minimize movement, adjust

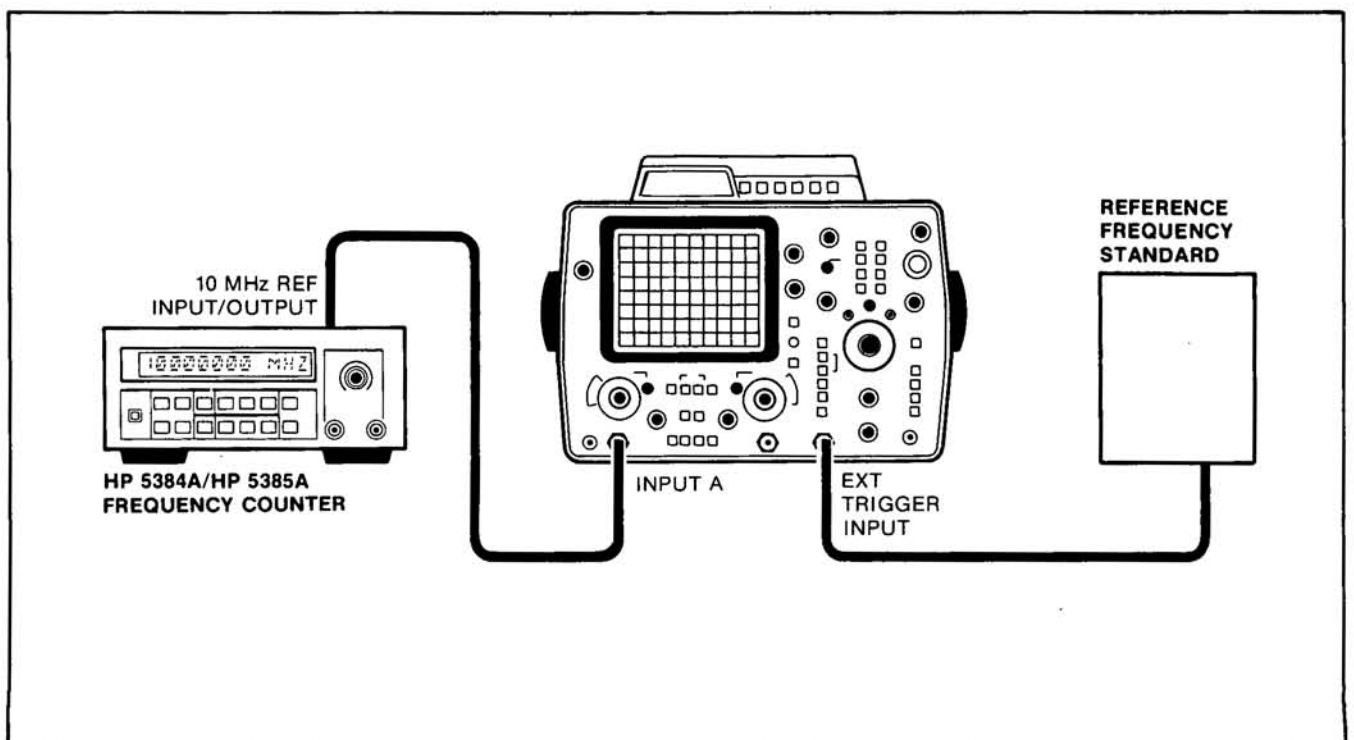

Figure 5-6. Standard, TCXO and Oven Oscillator Test Setup

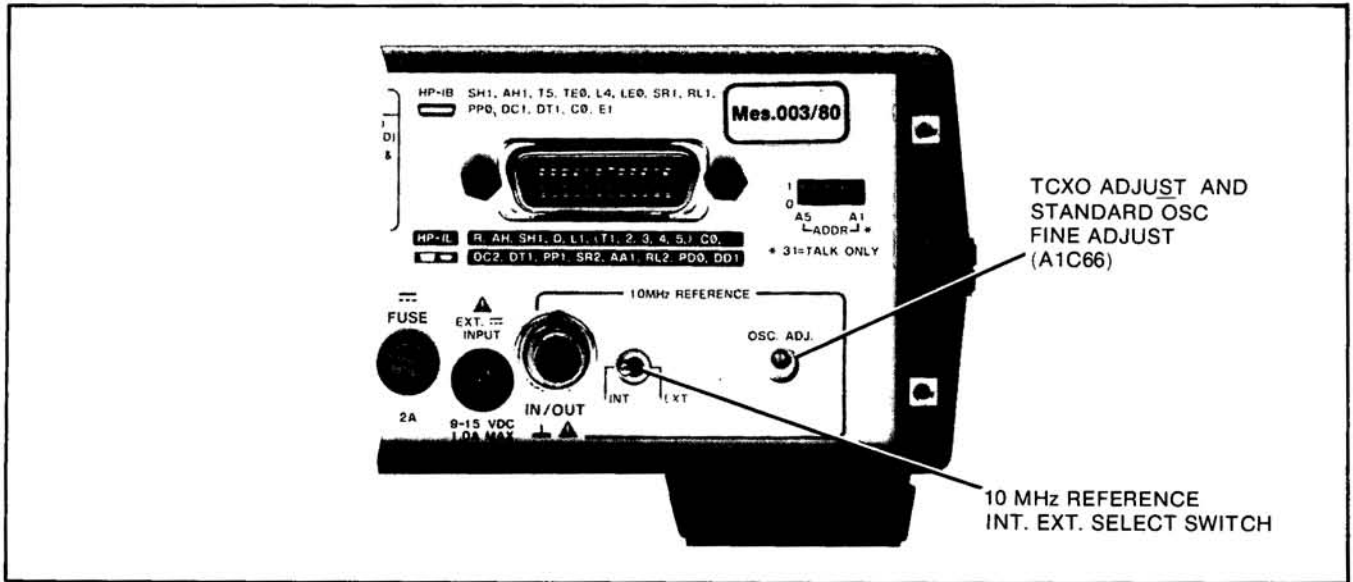

Figure 5-7. TCXO and Standard Oscillator Adjustment

A1C65 (coarse adjustment, see Figure 5-8 for location) until the display is close enough for adjustment with A1C66.

based on the HP 1740A oscilloscope sweep speed as shown in Table 5-2.

NOTE

For access to A1C65, remove the top cover. The interface board should not have to be removed to access and adjust A1C65. Remove the top cover by removing the 4 screws located at the bottom of the counter.

e. By timing the sideways movement (in cm/second), the approximate offset can be determined

Table 5-2. Approximate Offset Determination Table

MOVEMENT	SWEEP SPEED			NOTES
	1 μ s/cm	0.1 μ s/cm	0.01 μ s/cm	
1cm/s	1 \times 10 ⁻⁶	1 \times 10 ⁻⁷	1 \times 10 ⁻⁸	Time scope trace movement with second hand of watch or clock
1cm/10s	1 \times 10 ⁻⁷	1 \times 10 ⁻⁸	1 \times 10 ⁻⁹	
1cm/1000s	1 \times 10 ⁻⁸	1 \times 10 ⁻⁹	1 \times 10 ⁻¹⁰	

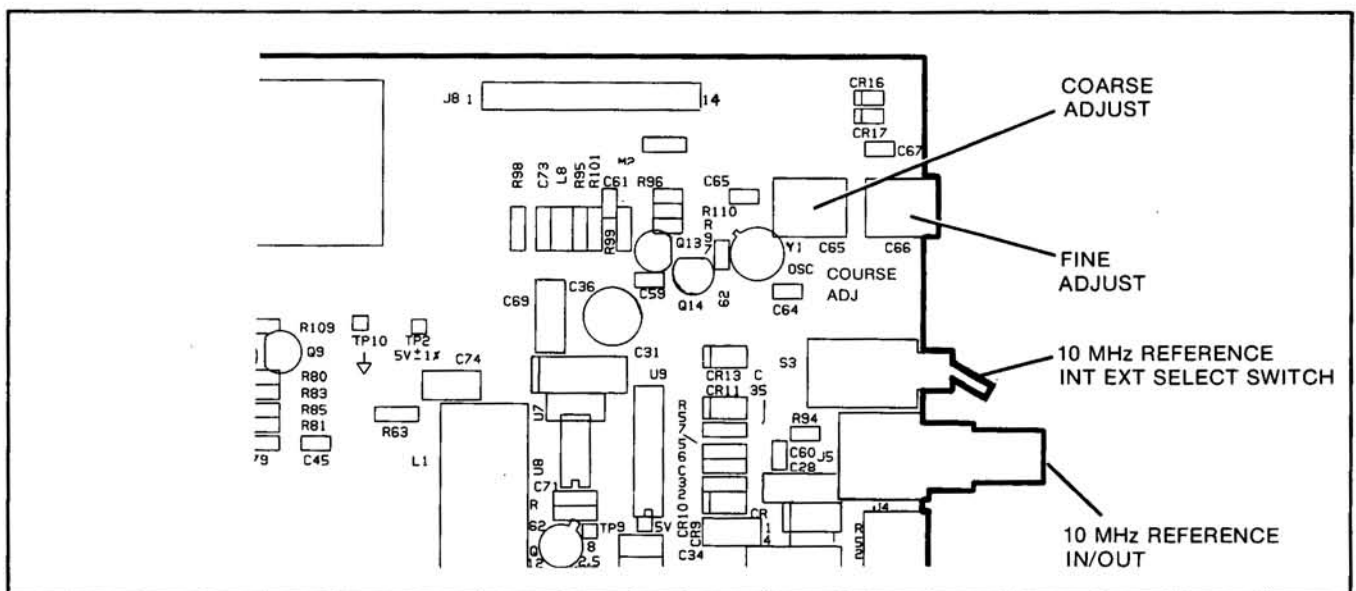

Figure 5-8. Standard Oscillator Coarse and Fine Adjustment Location

f. This completes the adjustment of the standard oscillator or the TCXO for use near 25°C.

5-24. Adjustment Of The TCXO With Offset (0° to 40°C):

a. To observe the offset stamped on the label of the TCXO, remove the top cover by removing the four screws located in the bottom half of the cabinet. For access to the two screws at the rear of the counter, remove the rear feet. Lift off the top.

b. Connect a house standard (reference frequency) to Channel A of the HP 5384A/HP 5385A as shown in *Figure 5-6*.

c. Cycle the HP 5384A/HP 5385A from STBY to ON. Press the DISPLAY DIGITS "up" (⇧) key once.

NOTE

Allow 30 minutes warm-up time for the counter.

d. Adjust the TCXO frequency to 10 MHz ± the offset labeled on the TCXO. For example, if the offset is +3.5 Hz (3.5 Hz above 10 MHz), then the TCXO should be adjusted so the 10 MHz input frequency appears to be 9.9999965 MHz (which is 3.5 Hz below the TCXO frequency) on the counter display at a room temperature of 25°C.

e. Reinstall the covers; the TCXO offset adjustment is completed.

5-25. Oven Oscillator Adjustment Procedure

a. Remove the top cover by removing the four screws located in the bottom half of the cabinet. (For access to the two screws at the rear of the counter, remove the rear feet.) Lift off the top.

b. The HP 5384A/HP 5385A should now be allowed to operate for at least 30 minutes before proceeding with the oscillator adjustment.

c. Connect a house standard (reference frequency) to the EXT TRIGGER input of an HP 1740A oscilloscope as shown in *Figure 5-6*. Set the 1740A Oscilloscope to External Trigger.

d. Connect the HP 5384A/HP 5385A rear panel 10 MHz REFERENCE IN OUT to the Channel A input of the HP 1740A oscilloscope as shown in *Figure 5-6*.

e. Turn the adjustment screw on the oven oscillator for minimum sideways movement of the signal on the oscilloscope.

f. By timing the sideways movement (in cm/second), the approximate offset can be determined based on the HP 1740A oscilloscope sweep speed as shown in *Table 5-2*.

g. This completes the adjustment of the oven oscillator.

5-26. HP 5384A/HP 5385A Battery Charger Adjustment Procedure

5-27. The A3 battery charger board requires adjustment if U1, U2, or Q1 have been replaced.

5-28. To perform the battery charger adjustments, make the following preparations:

a. Remove the top cover and place to the right of the counter. Leave the battery charger circuit connected (via ribbon cable W2).

b. Disconnect A3B1 6-volt battery from the circuit by removing A3W1 and A3W2 from the battery.

5-29. Fast Charge Current Adjustment:

a. Set the power STBY/ON switch to STBY. Connect the ac power plug to the rear of the instrument. Set A3R26 fully clockwise.

b. Connect the A3 battery charger to an HP 3465A voltmeter and 10Ω, 20W resistor as shown in *Figure 5-9*.

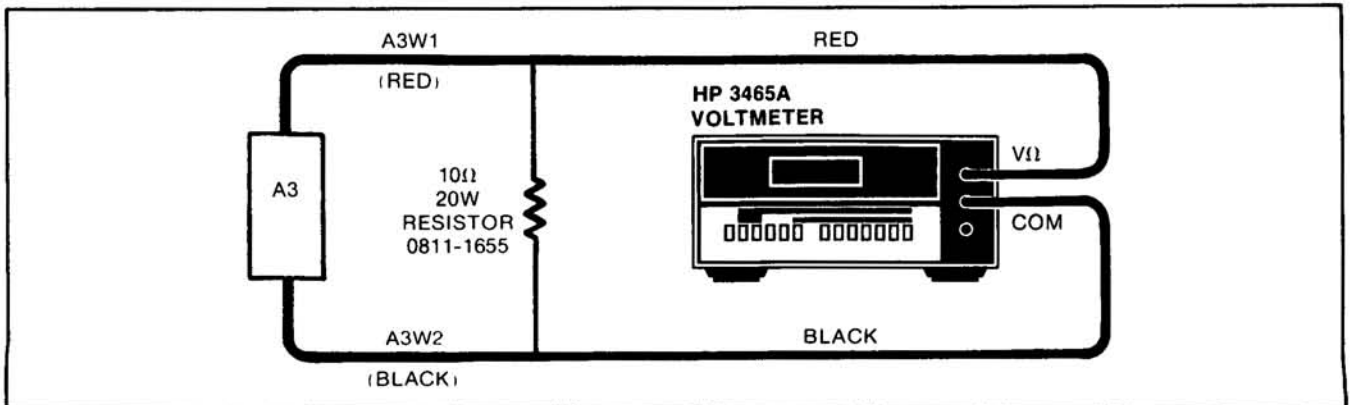

Figure 5-9. Fast Charge Current Adjustment Setup

HP 5384A and HP 5385A
Adjustments

c. Adjust A3R25 for a DVM reading of 5 volts ± 0.5 volts; A3R25 may be fully clockwise.

d. Set the counter STBY/ON switch to ON; observe the DVM reading to be approximately 90 mV ± 10 mV. Set the switch back to STBY.

5-30. Fast Charge Threshold Adjustment:

a. Connect the HP 5384A/HP 5385A as shown in Figure 5-10.

b. Set A3R26 fully counterclockwise. Set the HP 6237B Power Supply to its 18-volt range and adjust to 7 volts ± 10 mV.

c. Slowly adjust A3R26 clockwise while observing the ammeter on the HP 6237B Power Supply. Con-

tinue the clockwise adjustment until the ammeter drops to about 200 mA ± 100 mA.

d. Turn all test equipment off and disconnect the power cable from the counter. Disconnect the 10 ohm, 20 watt resistor.

e. Reconnect the A3 Charger board red and black battery wires. Observe proper polarity (red is positive, black is negative) and ensure the wire clips are fully engaged.

f. Replace the top cover. Ensure the four black plastic hold-down tubes, HP Part Number 4177-0236, are in place. As the cover is being positioned, ensure the W2 ribbon cable assembly will not be pinched between the top and bottom covers.

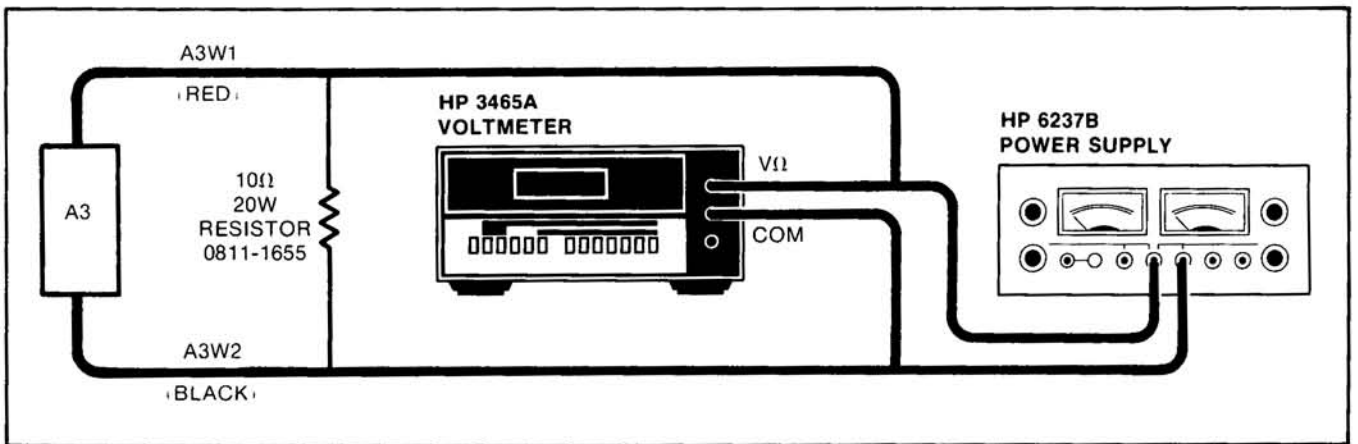

Figure 5-10. Fast Charge Threshold Adjustment Setup

SECTION VI REPLACEABLE PARTS

6-1. INTRODUCTION

6-2. This section contains information for ordering parts. *Table 6-1* lists abbreviations used in the parts list and throughout the manual. *Tables 6-2 through 6-10* list all replaceable parts in reference designation order. *Table 6-11* contains the name and addresses that correspond with the manufacturer's code numbers. *Tables 6-12 and 6-13* list the hardware and mechanical parts for the HP 5384A and HP 5385A, respectively. *Figures 6-1 and 6-2* are exploded views of the hardware and mechanical parts in the HP 5384A/HP 5385A.

6-3. ABBREVIATIONS

6-4. *Table 6-1* lists abbreviations used in the parts lists, schematics, and throughout the manual. In some cases, two forms of the abbreviations are used, one all in capital letters, and one partial or no capitals. This occurs because the abbreviations in the parts are always capitals. However, in the schematics and other parts of the manual, other abbreviations are used with both lower case and upper case letters.

6-5. REPLACEABLE PARTS LISTS

6-6. *Tables 6-2 through 6-12* are the lists of replaceable parts and are organized as follows:

- a. Electrical assemblies and their components in alphanumeric order by reference designation.
- b. Miscellaneous parts.

6-7. The information given for each part consists of the following:

- a. The reference designation.
- b. The Hewlett-Packard part number.
- c. Part number check digit (CD).
- d. The total quantity (Qty) used in the instrument.
- e. The description of the part.
- f. A typical manufacturer of the part in a five-digit code.
- g. The manufacturer's number for the part.

6-8. The total quantity for each part is given only once at the first appearance of the part number in the list.

6-9. ORDERING INFORMATION

6-10. To order a part listed in the replaceable parts table, quote the Hewlett-Packard part number (with the check list) indicate the quantity required, and address the order to the nearest Hewlett-Packard office. The check digit ensures accurate and timely processing of your order.

6-11. To order a part that is not listed in the replaceable parts table, include the instrument model number, HP 5384A or HP 5385A serial number, the description and function of the part, and the number of parts required. Address the order to the nearest Hewlett-Packard office.

6-12. DIRECT MAIL ORDER SYSTEM

6-13. Within the USA, Hewlett-Packard can supply parts through a direct mail order system. Advantages of using the system are:

- a. Direct ordering and shipment from the HP Parts Center in Mountain View, California.
- b. No maximum or minimum on any order (there is a minimum order amount for parts ordered through a local HP office with the orders require billing and invoicing).

6-14. Mail order forms and specific ordering information is available through your local HP office. Address and phone numbers are located at the back of this manual.

Table 6-1. Abbreviations and Reference Designations

REFERENCE DESIGNATIONS			
A	= assembly	DL	= delay line
AT	= attenuator; isolator; termination	DS	= annunciator; signaling device (audible or visual); lamp; LED
B	= fan; motor	E	= miscellaneous electrical part
BT	= battery	F	= fuse
C	= capacitor	FL	= filter
CP	= coupler	H	= hardware
CR	= diode; diode thyristor; varactor	HY	= circulator
DC	= directional coupler	J	= electrical connector (stationary portion); jack
		K	= relay
		L	= coil; inductor
		M	= metre
		MP	= miscellaneous mechanical part
		P	= electrical connector (movable portion); plug
		Q	= transistor; SCR; triode thyristor
		R	= resistor
		RT	= thermistor
		S	= switch
		T	= transformer
		TB	= terminal board
		TC	= thermocouple
		TP	= test point
		U	= integrated circuit; microcircuit
		V	= electron tube
		VR	= voltage regulator; breakdown diode
		W	= cable; transmission path; wire
		X	= socket
		Y	= crystal unit-piezo-electric
		Z	= tuned cavity; tuned circuit

ABBREVIATIONS			
A	= ampere	HD	= head
ac	= alternating current	HDW	= hardware
ACCESS	= accessory	HF	= high frequency
ADJ	= adjustment	HG	= mercury
A/D	= analog-to-digital	HI	= high
AF	= audio frequency	HP	= Hewlett-Packard
AFC	= automatic frequency control	HPF	= high pass filter
AGC	= automatic gain control	HR	= hour (used in parts list)
AL	= aluminum	HV	= high voltage
ALC	= automatic level control	Hz	= hertz
AM	= amplitude modulation	IC	= integrated circuit
AMPL	= amplifier	ID	= inside diameter
APC	= automatic phase control	IF	= intermediate frequency
ASSY	= assembly	IMPG	= impregnated
AUX	= auxiliary	in	= inch
AVG	= average	INCD	= incandescent
AWG	= american wire gauge	INCL	= include(s)
BAL	= balance	INP	= input
BCD	= binary coded decimal	INS	= insulation
BD	= board	INT	= internal
BE CU	= beryllium copper	kg	= kilogram
BFO	= beat frequency oscillator	kHz	= kilohertz
BH	= binder head	kΩ	= kilohm
BKDN	= breakdown	kV	= kilovolt
BP	= bandpass	lb	= pound
BPF	= bandpass filter	LC	= inductance-capacitance
BRS	= brass	LED	= light-emitting diode
BWO	= backward-wave oscillator	LF	= low frequency
CAL	= calibrate	LG	= long
ccw	= counterclockwise	LH	= left hand
CER	= ceramic	LIM	= limit
CHAN	= channel	lin	= linear taper (used in parts list)
cm	= centimeter	lin	= linear
CMO	= coaxial	LK WASH	= lockwasher
COEF	= coefficient	LO	= low; local oscillator
COM	= common	LOG	= logarithmic taper (used in parts list)
COMP	= composition	log	= logarithm(ic)
COMPL	= complete	LPF	= low pass filter
CONN	= connector	LV	= low voltage
CP	= cadmium plate	m	= metre (distance)
CRT	= cathode-ray tube	mA	= milliamperes
CTL	= complementary transistor logic	MAX	= maximum
CW	= continuous wave	MΩ	= megohm
cw	= clockwise	MEG	= meg (10 ⁶) (used in parts list)
D/A	= digital-to-analog	MET FLM	= metal film
dB	= decibel	MET OX	= metal oxide
dBm	= decibel referred to 1 mW	MF	= medium frequency; microfarad (used in parts list)
dc	= direct current	MFR	= manufacturer
deg	= degree (temperature interval or difference)	mg	= milligram
°	= degree (plane angle)	MHz	= megahertz
°C	= degree Celsius (centigrade)	mH	= millihenry
°F	= degree Fahrenheit	mho	= conductance
*K	= degree Kelvin	MIN	= minute (time)
DEPC	= deposited carbon	min	= minute (plane angle)
DET	= detector	...	
diam	= diameter	MINAT	= miniature
DIA	= diameter (used in parts list)	mm	= millimetre
DIFF AMPL	= differential amplifier	MOD	= modulator
div	= division	MOM	= momentary
DPDT	= double-pole, double-throw	MOS	= metal-oxide semiconductor
DR	= drive	ms	= millisecond
DSB	= double sideband	MTG	= mounting
DTL	= diode transistor logic	MTR	= meter (indicating device)
DVM	= digital voltmeter	mV	= millivolt
ECL	= emitter coupled logic	mVac	= millivolt, ac
EMF	= electromotive force	mVdc	= millivolt, dc
EDP	= electronic data processing	mVpk	= millivolt, peak
ELECT	= electrolytic	mVp-p	= millivolt, peak-to-peak
ENCAP	= encapsulated	mVrms	= millivolt, rms
EXT	= external	mW	= milliwatt
F	= farad	MUX	= multiplex
FET	= field-effect transistor	MY	= mylar
F/F	= flip-flop	μA	= microampere
FH	= flat head	μF	= microfarad
FOL H	= filister head	μH	= microhenry
FM	= frequency modulation	μmho	= micromho
FP	= front panel	μs	= microsecond
FREQ	= frequency	μV	= microvolt
FXD	= fixed	μVac	= microvolt, ac
g	= gram	μVdc	= microvolt, dc
GE	= germanium	μVpk	= microvolt, peak
GHZ	= gigahertz	μVp-p	= microvolt, peak-to-peak
GL	= glass	μVrms	= microvolt, rms
GND	= ground(ed)	μW	= microwatt
H	= henry	nA	= nanoampere
h	= hour	NC	= no connection
HET	= heterodyne	N/C	= normally closed
HEX	= hexagonal		
		NE	= neon
		NEG	= negative
		nF	= nanofarad
		NI PL	= nickel plate
		N/O	= normally open
		NOM	= nominal
		NORM	= normal
		NPN	= negative-positive-negative
		NPO	= negative-positive zero (zero temperature coefficient)
		NRFR	= not recommended for field replacement
		ns	= nanosecond
		NSR	= not separately replaceable
		nW	= nanowatt
		OB	= order by description
		OD	= outside diameter
		OH	= oval head
		OP AMPL	= operational amplifier
		OPT	= option
		OSC	= oscillator
		OX	= oxide
		oz	= ounce
		Ω	= ohm
		P	= peak (used in parts list)
		PAM	= pulse-amplitude modulation
		PC	= printed circuit
		PCM	= pulse-code modulation; pulse-count modulation
		PDM	= pulse-duration modulation
		pF	= picofarad
		PH BRZ	= phosphor bronze
		PHL	= philips
		PIN	= positive-intrinsic-negative
		PIV	= peak inverse voltage
		pk	= peak
		PL	= phase lock
		PLO	= phase lock oscillator
		PM	= phase modulation
		PNP	= positive-negative-positive
		P/O	= part of
		POLY	= polystyrene
		PORC	= porcelain
		POS	= positive; position(s) (used in parts list)
		POSN	= position
		POT	= potentiometer
		p-p	= peak-to-peak
		PP	= peak-to-peak (used in parts list)
		PPM	= pulse-position modulation
		PREAMPL	= preamplifier
		PRF	= pulse-repetition frequency
		PRR	= pulse repetition rate
		ps	= picosecond
		PT	= point
		PTM	= pulse-time modulation
		PWM	= pulse-width modulation
		PWV	= peak working voltage
		RC	= resistance capacitance
		RECT	= rectifier
		REF	= reference
		REG	= regulated
		REPL	= replaceable
		RF	= radio frequency
		RFI	= radio frequency interference
		RH	= round head; right hand
		RLC	= resistance-inductance-capacitance
		RMO	= rack mount only
		rms	= root-mean-square
		RND	= round
		ROM	= read-only memory
		R&P	= rack and panel
		RWV	= reverse working voltage
		S	= scattering parameter
		s	= second (time)
		...	= second (plane angle)
		S-B	= slow-blow fuse (used in parts list)
		SCR	= silicon controlled rectifier; screw
		SE	= selenium
		SECT	= sections
		SEMICON	= semiconductor
		SHF	= superhigh frequency
		SI	= silicon
		SIL	= silver
		SL	= slide
		SNR	= signal-to-noise ratio
		SPDT	= single-pole, double-throw
		SPG	= spring
		SR	= split ring
		SPST	= single-pole, single-throw
		SSB	= single sideband
		SST	= stainless steel
		STL	= steel
		SQ	= square
		SWR	= standing-wave ratio
		SYNC	= synchronize
		T	= timed (slow-blow fuse)
		TA	= tantalum
		TC	= temperature compensating
		TD	= time delay
		TERM	= terminal
		TFT	= thin-film transistor
		TGL	= toggle
		THD	= thread
		THRU	= through
		TI	= titanium
		TOL	= tolerance
		TRIM	= trimmer
		TSTR	= transistor
		TTL	= transistor-transistor logic
		TV	= television
		TVI	= television interference
		TWT	= traveling wave tube
		U	= micro (10 ⁻⁶) (used in parts list)
		UF	= microfarad (used in parts list)
		UHF	= ultrahigh frequency
		UNREG	= unregulated
		V	= volt
		VA	= voltampere
		Vac	= volts ac
		VAR	= variable
		VCO	= voltage-controlled oscillator
		Vdc	= volts dc
		VDCW	= volts, dc, working (used in parts list)
		V(F)	= volts, filtered
		VFO	= variable-frequency oscillator
		VHF	= very-high frequency
		Vpk	= volts peak
		Vp-p	= volts peak-to-peak
		Vrms	= volts rms
		VSWR	= voltage standing wave ratio
		VTO	= voltage-tuned oscillator
		VTVM	= vacuum-tube voltmeter
		V(X)	= volts, switched
		W	= watt
		W/	= with
		WIV	= working inverse voltage
		WW	= wirewound
		W/O	= without
		YIG	= yttrium-iron-garnet
		Zo	= characteristic impedance

NOTE
All abbreviations in the parts list will be in upper case.

MULTIPLIERS

Abbreviation	Prefix	Multiple
T	tera	10 ¹²
G	giga	10 ⁹
M	mega	10 ⁶
k	kilo	10 ³
da	deka	10
d	deci	10 ⁻¹
c	centi	10 ⁻²
m	milli	10 ⁻³
μ	micro	10 ⁻⁶
n	nano	10 ⁻⁹
p	pico	10 ⁻¹²
f	femto	10 ⁻¹⁵
a	atto	10 ⁻¹⁸

Table 6-2. HP 5384A Replaceable Parts

Reference Designation	HP Part Number	C D	Qty	Description	Mfr Code	Mfr Part Number
A1	05384-60001	6	1	BOARD ASSEMBLY, MAIN (SERIES 2430)	28480	05384-60001
A1C1	0160-4704	9	1	CAPACITOR-FXD .01UF +-10% 500VDC CER	28480	0160-4704
A1C2	0160-5649	3	1	CAPACITOR-FXD 100PF + 5% 500VDC CER	28480	0160-5649
A1C3	0160-4385	2	1	CAPACITOR-FXD 15PF +-5% 200VDC CER 0+-30	28480	0160-4385
A1C4	0180-2816	2	1	CAPACITOR-FXD 68UF+-20% 10VDC TA	28480	0180-2816
A1C5	0180-0562	1	5	CAPACITOR-FXD 33UF+-20% 10VDC TA	56289	196D336X0010KA1
A1C6	0160-0573	2	1	CAPACITOR-FXD 4700PF +-20% 100VDC CER	28480	0160-0573
A1C7	0180-0562	1	1	CAPACITOR-FXD 33UF+-20% 10VDC TA	56289	196D336X0010KA1
A1C8	0160-0572	1	1	CAPACITOR-FXD 2200PF +-20% 100VDC CER	28480	0160-0572
A1C9	0160-3879	7	17	CAPACITOR-FXD .01UF +-20% 100VDC CER	28480	0160-3879
A1C10	0160-3879	7	7	CAPACITOR-FXD .01UF +-20% 100VDC CER	28480	0160-3879
A1C11	0160-4492	2	2	CAPACITOR-FXD 18PF +-5% 200VDC CER 0+-30	28480	0160-4492
A1C12	0160-4492	2	2	CAPACITOR-FXD 18PF +-5% 200VDC CER 0+-30	28480	0160-4492
A1C13	0180-0562	1	1	CAPACITOR-FXD 33UF+-20% 10VDC TA	56289	196D336X0010KA1
A1C14	0160-4423	9	1	CAPACITOR-FXD 470PF +-20% 500VDC CER	51642	200-500-X7R-471M
A1C15				NOT ASSIGNED		
A1C16	0180-2698	8	1	CAPACITOR-FXD 4.7UF+-10% 35VDC TA	28480	0180-2698
A1C17	0160-3879	7	7	CAPACITOR-FXD .01UF +-20% 100VDC CER	28480	0160-3879
A1C18	0160-3879	7	7	CAPACITOR-FXD .01UF +-20% 100VDC CER	28480	0160-3879
A1C19	0160-3879	7	7	CAPACITOR-FXD .01UF +-20% 100VDC CER	28480	0160-3879
A1C20	0160-3879	7	7	CAPACITOR-FXD .01UF +-20% 100VDC CER	28480	0160-3879
A1C21	0160-3879	7	7	CAPACITOR-FXD .01UF +-20% 100VDC CER	28480	0160-3879
A1C22*	0160-4040	6	1	CAPACITOR-FXD 1000PF +-5% 100VDC CER	28480	0160-4040
A1C23	0160-3879	7	7	CAPACITOR-FXD .01UF +-20% 100VDC CER	28480	0160-3879
A1C24				NOT ASSIGNED		
A1C25	0160-3879	7	7	CAPACITOR-FXD .01UF +-20% 100VDC CER	28480	0160-3879
A1C26	0160-3879	7	7	CAPACITOR-FXD .01UF +-20% 100VDC CER	28480	0160-3879
A1C27	0160-4554	7	8	CAPACITOR-FXD .01UF +-20% 50VDC CER	28480	0160-4554
A1C28	0160-0127	2	3	CAPACITOR-FXD 1UF +-20% 25VDC CER	28480	0160-0127
A1C29	0180-3276	0	2	CAPACITOR-FXD 2200UF+100-10% 25VDC AL	28480	0180-3276
A1C30	0180-3276	0	0	CAPACITOR-FXD 2200UF+100-10% 25VDC AL	28480	0180-3276
A1C31	0180-0228	6	1	CAPACITOR-FXD 22UF+-10% 15VDC TA	56289	150D226X9015B2
A1C32	0160-4557	0	1	CAPACITOR-FXD .1UF +-20% 50VDC CER	16299	CAC04X7R104M050A
A1C33	0160-3879	7	7	CAPACITOR-FXD .01UF +-20% 100VDC CER	28480	0160-3879
A1C34	0160-4819	7	2	CAPACITOR-FXD 2200PF +-5% 100VDC CER	28480	0160-4819
A1C35	0160-4822	2	3	CAPACITOR-FXD 1000PF +-5% 100VDC CER	28480	0160-4822
A1C36	0180-3279	3	1	CAPACITOR-FXD 390UF+100-10% 12VDC AL	28480	0180-3279
A1C37	0160-3879	7	7	CAPACITOR-FXD .01UF +-20% 100VDC CER	28480	0160-3879
A1C38	0160-3879	7	7	CAPACITOR-FXD .01UF +-20% 100VDC CER	28480	0160-3879
A1C39	0160-3879	7	7	CAPACITOR-FXD .01UF +-20% 100VDC CER	28480	0160-3879
A1C40	0180-0291	3	3	CAPACITOR-FXD 1UF+-10% 35VDC TA	56289	150D105X9035A2
A1C41	0160-4554	7	7	CAPACITOR-FXD .01UF +-20% 50VDC CER	28480	0160-4554
A1C42	0160-4554	7	7	CAPACITOR-FXD .01UF +-20% 50VDC CER	28480	0160-4554
A1C43	0180-0291	3	3	CAPACITOR-FXD 1UF+-10% 35VDC TA	56289	150D105X9035A2
A1C44	0180-0291	3	3	CAPACITOR-FXD 1UF+-10% 35VDC TA	56289	150D105X9035A2
A1C45	0160-3879	7	7	CAPACITOR-FXD .01UF +-20% 100VDC CER	28480	0160-3879
A1C46	0160-4822	2	2	CAPACITOR-FXD 1000PF +-5% 100VDC CER	28480	0160-4822
A1C47	0160-4554	7	7	CAPACITOR-FXD .01UF +-20% 50VDC CER	28480	0160-4554
A1C48	0160-4822	2	2	CAPACITOR-FXD 1000PF +-5% 100VDC CER	28480	0160-4822
A1C49	0160-4554	7	7	CAPACITOR-FXD .01UF +-20% 50VDC CER	28480	0160-4554
A1C50	0160-4810	8	1	CAPACITOR-FXD 330PF +-5% 100VDC CER	28480	0160-4810
A1C51	0160-4554	7	7	CAPACITOR-FXD .01UF +-20% 50VDC CER	28480	0160-4554
A1C52	0160-4554	7	7	CAPACITOR-FXD .01UF +-20% 50VDC CER	28480	0160-4554
A1C53	0160-0127	2	2	CAPACITOR-FXD 1UF +-20% 25VDC CER	28480	0160-0127
A1C54	0180-0418	6	1	CAPACITOR-FXD 1UF+-20% 35VDC TA	28480	0180-0418
A1C55	0160-4808	4	3	CAPACITOR-FXD 470PF +-5% 100VDC CER	28480	0160-4808
A1C56	0160-4808	4	4	CAPACITOR-FXD 470PF +-5% 100VDC CER	28480	0160-4808
A1C57	0160-4808	4	4	CAPACITOR-FXD 470PF +-5% 100VDC CER	28480	0160-4808
A1C58	0160-4554	7	7	CAPACITOR-FXD .01UF +-20% 50VDC CER	28480	0160-4554
A1C59	0160-3879	7	7	CAPACITOR-FXD .01UF +-20% 100VDC CER	28480	0160-3879
A1C60	0160-3878	6	1	CAPACITOR-FXD 1000PF +-20% 100VDC CER	28480	0160-3878
A1C61	0160-3879	7	7	CAPACITOR-FXD .01UF +-20% 100VDC CER	28480	0160-3879
A1C62	0160-4801	7	1	CAPACITOR-FXD 100PF +-5% 100VDC CER	28480	0160-4801
A1C63	0160-4811	9	1	CAPACITOR-FXD 270PF +-5% 100VDC CER	28480	0160-4811
A1C64	0160-4786	7	1	CAPACITOR-FXD 27PF +-5% 100VDC CER 0+-30	28480	0160-4786
A1C65	0121-0105	4	1	CAPACITOR-V TRMR-CER 9-35PF 200V PC-MTG	52763	304324 9/35PF N650

See introduction to this section for ordering information
*Indicates factory selected value

HP 5384A and HP 5385A
Replaceable Parts

Table 6-2. HP 5384A Replaceable Parts (Continued)

Reference Designation	HP Part Number	C D	Qty	Description	Mfr Code	Mfr Part Number
A1C66	0121-0059	7	1	CAPACITOR-V TRMR-CER 2-8PF 350V PC-MTG	52763	304324 2/8PF NPO
A1C67				NOT ASSIGNED		
A1C68				NOT ASSIGNED		
A1C69	0160-0127	2		CAPACITOR-FXD 1UF +-20% 25VDC CER	28480	0160-0127
A1C70	0160-4819	7		CAPACITOR-FXD 2200PF +-5% 100VDC CER	28480	0160-4819
A1C71	0160-4805	1	1	CAPACITOR-FXD 47PF +-5% 100VDC CER 0+-30	28480	0160-4805
A1C72	0180-0562	1		CAPACITOR-FXD 33UF+-20% 10VDC TA	56289	196D336X0010KA1
A1C73				NOT ASSIGNED		
A1C74				NOT ASSIGNED		
A1C75	0180-0562	1		CAPACITOR-FXD 33UF+-20% 10VDC TA	56289	196D336X0010KA1
A1CR1	1901-0050	3	13	DIODE-SWITCHING 80V 200MA 2NS DO-35	28480	1901-0050
A1CR2	1901-0376	6	2	DIODE-GEN PRP 35V 50MA DO-35	28480	1901-0376
A1CR3	1901-0376	6		DIODE-GEN PRP 35V 50MA DO-35	28480	1901-0376
A1CR4	1901-0535	9	1	DIODE-SM SIG SCHOTTKY	28480	1901-0535
A1CR5	1901-0639	4	1	DIODE-PIN	28480	5082-3080
A1CR6	1901-0050	3		DIODE-SWITCHING 80V 200MA 2NS DO-35	28480	1901-0050
A1CR7	1901-0050	3		DIODE-SWITCHING 80V 200MA 2NS DO-35	28480	1901-0050
A1CR8	1906-0096	7	1	DIODE-FW BRDG 200V 2A	04713	MDA202
A1CR9	1884-0221	2	1	THYRISTOR-SCR VRRM=300	04713	MCR106-5
A1CR10	1902-3234	3	1	DIODE-ZNR 19.6V 5% DO-35 PD=.4W	28480	1902-3234
A1CR11	1901-0050	3		DIODE-SWITCHING 80V 200MA 2NS DO-35	28480	1901-0050
A1CR12	1901-0782	8	2	DIODE-SCHOTTKY 1N5821 30V 3A	04713	1N5821
A1CR13	1902-3110	4	1	DIODE-ZNR 5.9V 2% DO-35 PD=.4W TC=+.017%	28480	1902-3110
A1CR14	1901-0782	8		DIODE-SCHOTTKY 1N5821 30V 3A	04713	1N5821
A1CR15	1901-0050	3		DIODE-SWITCHING 80V 200MA 2NS DO-35	28480	1901-0050
A1CR16	1901-0050	3		DIODE-SWITCHING 80V 200MA 2NS DO-35	28480	1901-0050
A1CR17	1901-0050	3		DIODE-SWITCHING 80V 200MA 2NS DO-35	28480	1901-0050
A1CR18	1901-0050	3		DIODE-SWITCHING 80V 200MA 2NS DO-35	28480	1901-0050
A1CR19	1901-0050	3		DIODE-SWITCHING 80V 200MA 2NS DO-35	28480	1901-0050
A1CR20	1901-0050	3		DIODE-SWITCHING 80V 200MA 2NS DO-35	28480	1901-0050
A1CR21	1901-0050	3		DIODE-SWITCHING 80V 200MA 2NS DO-35	28480	1901-0050
A1CR22	1901-0050	3		DIODE-SWITCHING 80V 200MA 2NS DO-35	28480	1901-0050
A1CR23	1901-0050	3		DIODE-SWITCHING 80V 200MA 2NS DO-35	28480	1901-0050
A1E1	9170-0029	3	1	CORE-SHIELDING BEAD	28480	9170-0029
A1F1	2110-0201	0	1	FUSE .25A 250V TD 1.25X.25 UL	28480	2110-0201
A1F1	2110-0565	9	1	FUSEHOLDER CAP 12A MAX FOR UL	28480	2110-0565
A1F2	2110-0002	9	1	FUSE 2A 250V NTD 1.25X.25 UL	75915	312002
A1F3	2110-0301	1	1	FUSE .125A 125V .281X.093	28480	2110-0301
A1J1	1250-1782	9	2	CONNECTOR-RF BNC FEM PCH-PNL 50-OHM	28480	1250-1782
A1J2	1250-1782	9		CONNECTOR-RF BNC FEM PCH-PNL 50-OHM	28480	1250-1782
A1J3	1251-4743	0	1	CONNECTOR-AC PUR HP-9 MALE REC-FLG THRMP	28480	1251-4743
A1J4	1251-8261	5	1	JACK POWER PCB MT	28480	1251-8261
A1J5	1250-1842	2	1	BNC RTANG PC MNT	28480	1250-1842
A1J6	1251-8304	7	1	CONN-POST TYPE .100-PIN-SPCG 8-CONT	28480	1251-8304
A1J7				NOT ASSIGNED		
A1J8	1251-7684	4	1	CABLE ASSY 14 POST	28480	1251-7684
A1J9	1251-8139	6	1	CONN-POST TYPE .100-PIN-SPCG 14-CONT	28480	1251-8139
A1K1	0490-1317	3	1	RELAY-REED 1C 250MA 200VDC 5VDC-COIL 3VA	28480	0490-1317
A1L1	9140-0718	4	1	INDUCTOR-FIXED NORM IND: 230UH à 1.5ADC	28480	9140-0718
A1L2	9100-1788	6	4	CORE-FERRITE CHOKE-WIDEBAND; IMP:>680	28480	9100-1788
A1L3	9100-1788	6		CORE-FERRITE CHOKE-WIDEBAND; IMP:>680	28480	9100-1788
A1L4	9100-2562	6	1	INDUCTOR RF-CH-MLD 100UH 10%	28480	9100-2562
A1L5				NOT ASSIGNED		
A1L6	9100-1788	6		CORE-FERRITE CHOKE-WIDEBAND; IMP:>680	28480	9100-1788
A1L7	9100-1788	6		CORE-FERRITE CHOKE-WIDEBAND; IMP:>680	28480	9100-1788
A1Q1	1854-0215	1	5	TRANSISTOR NPN SI PD=350MW FT=300MHZ	04713	2N3904
A1Q2	1855-0327	8	1	TRANSISTOR J-FET 2N4416 N-CHAN D-MODE	01295	2N4416
A1Q3	1853-0354	7	1	TRANSISTOR PNP SI TO-92 PD=350MW	28480	1853-0354
A1Q4	1855-0414	4	1	TRANSISTOR J-FET 2N4393 N-CHAN D-MODE	04713	2N4393
A1Q5	1854-0215	1		TRANSISTOR NPN SI PD=350MW FT=300MHZ	04713	2N3904
A1Q6	1854-0574	5	1	TRANSISTOR NPN SI PD=500MW FT=125MHZ	28480	1854-0574
A1Q7	1854-0215	1		TRANSISTOR NPN SI PD=350MW FT=300MHZ	04713	2N3904
A1Q8	1853-0015	7	2	TRANSISTOR PNP SI PD=200MW FT=500MHZ	28480	1853-0015
A1Q9	1853-0015	7		TRANSISTOR PNP SI PD=200MW FT=500MHZ	28480	1853-0015
A1Q10	1853-0363	8	1	TRANSISTOR PNP SI PD=50W FT=20MHZ	03508	X45H281

See introduction to this section for ordering information
*Indicates factory selected value

Table 6-2. HP 5384A Replaceable Parts (Continued)

Reference Designation	HP Part Number	C D	Qty	Description	Mfr Code	Mfr Part Number
A1Q11	1854-0013	7	1	TRANSISTOR NPN 2N2218A SI TO-5 PD=800MW	04713	2N2218A
A1Q12	1854-0477	7	1	TRANSISTOR NPN 2N2222A SI TO-18 PD=500MW	04713	2N2222A
A1Q13	1854-0215	1		TRANSISTOR NPN SI PD=350MW FT=300MHZ	04713	2N3904
A1Q14	1854-0215	1		TRANSISTOR NPN SI PD=350MW FT=300MHZ	04713	2N3904
A1R1	0698-8827	4	2	RESISTOR 1M 1% .125W F TC=0+-100	28480	0698-8827
A1R2	0757-0706	8	3	RESISTOR 51.1 1% .25W F TC=0+-100	24546	C5-1/4-T0-51R1-F
A1R3	0698-8827	4		RESISTOR 1M 1% .125W F TC=0+-100	28480	0698-8827
A1R4	0699-0071	6	2	RESISTOR 4.64M 1% .125W F TC=0+-100	28480	0699-0071
A1R5	0698-7276	5	1	RESISTOR 46.4K 1% .05W F TC=0+-100	24546	C3-1/8-T0-4642-F
A1R6	0757-0346	2	2	RESISTOR 10 1% .125W F TC=0+-100	24546	C4-1/8-T0-10R0-F
A1R7	0757-0421	4	3	RESISTOR 825 1% .125W F TC=0+-100	24546	C4-1/8-T0-825R-F
A1R8	0698-3445	2	2	RESISTOR 348 1% .125W F TC=0+-100	24546	C4-1/8-T0-348R-F
A1R9	0698-7236	7	4	RESISTOR 1K 1% .05W F TC=0+-100	24546	C3-1/8-T0-1001-F
A1R10	0698-7233	4	1	RESISTOR 750 1% .05W F TC=0+-100	24546	C3-1/8-T0-750R-F
A1R11	0698-7283	4	1	RESISTOR 90.9K 1% .05W F TC=0+-100	24546	C3-1/8-T0-9092-F
A1R12	0698-8812	7	1	RESISTOR 1 1% .125W F TC=0+-100	28480	0698-8812
A1R13	0698-3136	8	1	RESISTOR 17.8K 1% .125W F TC=0+-100	24546	C4-1/8-T0-1782-F
A1R14	0698-7244	7	2	RESISTOR 2.15K 1% .05W F TC=0+-100	24546	C3-1/8-T0-2151-F
A1R15	0698-3447	4	3	RESISTOR 422 1% .125W F TC=0+-100	24546	C4-1/8-T0-422R-F
A1R16	0698-3447	4		RESISTOR 422 1% .125W F TC=0+-100	24546	C4-1/8-T0-422R-F
A1R17	1810-0541	4	1	NETWORK-RES 6-SIP MULTI-VALUE	28480	1810-0541
A1R18	1810-0219	3	1	NETWORK-RES 8-SIP220.0 OHM X 4	01121	2088221
A1R19	0698-7220	9	3	RESISTOR 215 1% .05W F TC=0+-100	24546	C3-1/8-T0-215R-F
A1R20	0698-7220	9		RESISTOR 215 1% .05W F TC=0+-100	24546	C3-1/8-T0-215R-F
A1R21	0698-7249	2	2	RESISTOR 3.48K 1% .05W F TC=0+-100	24546	C3-1/8-T0-3481-F
A1R22	0757-0283	6	3	RESISTOR 2K 1% .125W F TC=0+-100	24546	C4-1/8-T0-2001-F
A1R23	0698-7267	4	1	RESISTOR 19.6K 1% .05W F TC=0+-100	24546	C3-1/8-T0-1962-F
A1R24	0698-7210	7	1	RESISTOR 82.5 1% .05W F TC=0+-100	24546	C3-1/8-T0-82R5-F
A1R25	0757-0706	8		RESISTOR 51.1 1% .25W F TC=0+-100	24546	C5-1/4-T0-51R1-F
A1R26	0757-0706	8		RESISTOR 51.1 1% .25W F TC=0+-100	24546	C5-1/4-T0-51R1-F
A1R27	0698-7244	7		RESISTOR 2.15K 1% .05W F TC=0+-100	24546	C3-1/8-T0-2151-F
A1R28	0698-7249	2		RESISTOR 3.48K 1% .05W F TC=0+-100	24546	C3-1/8-T0-3481-F
A1R29	0698-7236	7		RESISTOR 1K 1% .05W F TC=0+-100	24546	C3-1/8-T0-1001-F
A1R30	0698-3437	2	2	RESISTOR 133 1% .125W F TC=0+-100	24546	C4-1/8-T0-133R-F
A1R31	0698-3437	2		RESISTOR 133 1% .125W F TC=0+-100	24546	C4-1/8-T0-133R-F
A1R32	2100-0558	9	2	RESISTOR-TRMR 20K 10% C TOP-ADJ 1-TRN	28480	2100-0558
A1R33	0698-3442	9	1	RESISTOR 237 1% .125W F TC=0+-100	24546	C4-1/8-T0-237R-F
A1R34	0698-7265	2	1	RESISTOR 16.2K 1% .05W F TC=0+-100	24546	C3-1/8-T0-1622-F
A1R35	0698-7236	7		RESISTOR 1K 1% .05W F TC=0+-100	24546	C3-1/8-T0-1001-F
A1R36	0698-7229	8	6	RESISTOR 511 1% .05W F TC=0+-100	24546	C3-1/8-T0-511R-F
A1R37	0698-7205	0	3	RESISTOR 51.1 1% .05W F TC=0+-100	24546	C3-1/8-T0-51R1-F
A1R38	0698-7205	0		RESISTOR 51.1 1% .05W F TC=0+-100	24546	C3-1/8-T0-51R1-F
A1R39	0698-7229	8		RESISTOR 511 1% .05W F TC=0+-100	24546	C3-1/8-T0-511R-F
A1R40	0698-7220	9		RESISTOR 215 1% .05W F TC=0+-100	24546	C3-1/8-T0-215R-F
A1R41	0698-3156	2	2	RESISTOR 14.7K 1% .125W F TC=0+-100	24546	C4-1/8-T0-1472-F
A1R42	0698-7229	8		RESISTOR 511 1% .05W F TC=0+-100	24546	C3-1/8-T0-511R-F
A1R43	2100-0558	9		RESISTOR-TRMR 20K 10% C TOP-ADJ 1-TRN	28480	2100-0558
A1R44	0698-7284	5	2	RESISTOR 100K 1% .05W F TC=0+-100	24546	C3-1/8-T0-1003-F
A1R45*	0698-7206	1	1	RESISTOR 56.2 1% .05W F TC=0+-100	24546	C3-1/8-T0-56R2-F
A1R46	0698-7205	0		RESISTOR 51.1 1% .05W F TC=0+-100	24546	C3-1/8-T0-51R1-F
A1R47	0698-7229	8		RESISTOR 511 1% .05W F TC=0+-100	24546	C3-1/8-T0-511R-F
A1R48	0698-7243	6	1	RESISTOR 1.96K 1% .05W F TC=0+-100	24546	C3-1/8-T0-1961-F
A1R49	1810-0488	8	1	NETWORK-RES 8-SIP4.7K OHM X 4	28480	1810-0488
A1R50	0812-0021	8	1	RESISTOR .47 5% 3W PW TC=0+-90	91637	CU2B1-3-T2-47/100-J
A1R51	0698-7229	8		RESISTOR 511 1% .05W F TC=0+-100	24546	C3-1/8-T0-511R-F
A1R52	0757-0394	0	3	RESISTOR 51.1 1% .125W F TC=0+-100	24546	C4-1/8-T0-51R1-F
A1R53	0698-3132	4	3	RESISTOR 261 1% .125W F TC=0+-100	24546	C4-1/8-T0-2610-F
A1R54	0757-1093	8	2	RESISTOR 3K 1% .125W F TC=0+-100	24546	C4-1/8-T0-3001-F
A1R55	0757-0465	6	3	RESISTOR 100K 1% .125W F TC=0+-100	24546	C4-1/8-T0-1003-F
A1R56	0757-0407	6	1	RESISTOR 200 1% .125W F TC=0+-100	24546	C4-1/8-T0-201-F
A1R57	0757-0289	2	1	RESISTOR 13.9K 1% .125W F TC=0+-100	19701	MF4C1/8-T0-1332-F
A1R58	0757-0399	5	1	RESISTOR 82.5 1% .125W F TC=0+-100	24546	C4-1/8-T0-82R5-F
A1R59	0757-0416	7	4	RESISTOR 511 1% .125W F TC=0+-100	24546	C4-1/8-T0-511R-F
A1R60	0757-0346	2		RESISTOR 10 1% .125W F TC=0+-100	24546	C4-1/8-T0-10R0-F

See introduction to this section for ordering information
*Indicates factory selected value

HP 5384A and HP 5385A
Replaceable Parts

Table 6-2. HP 5384A Replaceable Parts (Continued)

Reference Designation	HP Part Number	C D	Qty	Description	Mfr Code	Mfr Part Number
A1R61	0698-3398	4	1	RESISTOR 46.4 1% .5W F TC=0+-100	28480	0698-3398
A1R62	0757-0200	7	2	RESISTOR 5.62K 1% .125W F TC=0+-100	24546	C4-1/8-T0-5621-F
A1R63	0757-0200	7		RESISTOR 5.62K 1% .125W F TC=0+-100	24546	C4-1/8-T0-5621-F
A1R64	0699-0071	6		RESISTOR 4.64M 1% .125W F TC=0+-100	28480	0699-0071
A1R65	1810-0370	7	1	NETWORK-RES 8-SIP220.0 OHM X 7	01121	208A221
A1R66	0757-0394	0		RESISTOR 51.1 1% .125W F TC=0+-100	24546	C4-1/8-T0-51R1-F
A1R67	0757-0394	0		RESISTOR 51.1 1% .125W F TC=0+-100	24546	C4-1/8-T0-51R1-F
A1R68	0698-3441	8	2	RESISTOR 215 1% .125W F TC=0+-100	24546	C4-1/8-T0-215R-F
A1R69	0698-3441	8		RESISTOR 215 1% .125W F TC=0+-100	24546	C4-1/8-T0-215R-F
A1R70	0698-7212	9	2	RESISTOR 100 1% .05W F TC=0+-100	24546	C3-1/8-T0-100R-F
A1R71	0698-7212	9		RESISTOR 100 1% .05W F TC=0+-100	24546	C3-1/8-T0-100R-F
A1R72	0698-3156	2		RESISTOR 14.7K 1% .125W F TC=0+-100	24546	C4-1/8-T0-1472-F
A1R73	0698-7197	9	1	RESISTOR 23.7 1% .05W F TC=0+-100	24546	C3-1/8-T0-23R7-F
A1R74	0698-7219	6	1	RESISTOR 196 1% .05W F TC=0+-100	24546	C3-1/8-T0-196R-F
A1R75	0757-0420	3	2	RESISTOR 750 1% .125W F TC=0+-100	24546	C4-1/8-T0-751-F
A1R76	0757-0419	0	1	RESISTOR 681 1% .125W F TC=0+-100	24546	C4-1/8-T0-681R-F
A1R77	2100-0554	5	1	RESISTOR-TRMR 500 10% C TOP-ADJ 1-TRN	28480	2100-0554
A1R78	0757-0465	6		RESISTOR 100K 1% .125W F TC=0+-100	24546	C4-1/8-T0-1003-F
A1R79	0757-0420	3		RESISTOR 750 1% .125W F TC=0+-100	24546	C4-1/8-T0-751-F
A1R80	0698-0082	7	5	RESISTOR 464 1% .125W F TC=0+-100	24546	C4-1/8-T0-4640-F
A1R81	0698-0082	7		RESISTOR 464 1% .125W F TC=0+-100	24546	C4-1/8-T0-4640-F
A1R82	0757-0283	6		RESISTOR 2K 1% .125W F TC=0+-100	24546	C4-1/8-T0-2001-F
A1R83	0757-1093	8		RESISTOR 3K 1% .125W F TC=0+-100	24546	C4-1/8-T0-3001-F
A1R84	0698-0082	7		RESISTOR 464 1% .125W F TC=0+-100	24546	C4-1/8-T0-4640-F
A1R85	0698-0082	7		RESISTOR 464 1% .125W F TC=0+-100	24546	C4-1/8-T0-4640-F
A1R86	0698-3445	2		RESISTOR 348 1% .125W F TC=0+-100	24546	C4-1/8-T0-348R-F
A1R87	0757-0421	4		RESISTOR 825 1% .125W F TC=0+-100	24546	C4-1/8-T0-825R-F
A1R88	0757-0421	4		RESISTOR 825 1% .125W F TC=0+-100	24546	C4-1/8-T0-825R-F
A1R89	0698-3460	1	1	RESISTOR 422K 1% .125W F TC=0+-100	28480	0698-3460
A1R90	0757-0416	7		RESISTOR 511 1% .125W F TC=0+-100	24546	C4-1/8-T0-511R-F
A1R91	0698-3132	4		RESISTOR 261 1% .125W F TC=0+-100	24546	C4-1/8-T0-2610-F
A1R92	0698-3132	4		RESISTOR 261 1% .125W F TC=0+-100	24546	C4-1/8-T0-2610-F
A1R93	0757-0280	3	2	RESISTOR 1K 1% .125W F TC=0+-100	24546	C4-1/8-T0-1001-F
A1R94	0698-7229	8		RESISTOR 511 1% .05W F TC=0+-100	24546	C3-1/8-T0-511R-F
A1R95	0757-0416	7		RESISTOR 511 1% .125W F TC=0+-100	24546	C4-1/8-T0-511R-F
A1R96	0698-7236	7		RESISTOR 1K 1% .05W F TC=0+-100	24546	C3-1/8-T0-1001-F
A1R97	0698-7248	1	1	RESISTOR 3.16K 1% .05W F TC=0+-100	24546	C3-1/8-T0-3161-F
A1R98	0757-0465	6		RESISTOR 100K 1% .125W F TC=0+-100	24546	C4-1/8-T0-1003-F
A1R99	0757-0401	0	2	RESISTOR 100 1% .125W F TC=0+-100	24546	C4-1/8-T0-101-F
A1R100				NOT ASSIGNED		
A1R101	0698-3447	4		RESISTOR 422 1% .125W F TC=0+-100	24546	C4-1/8-T0-422R-F
A1R102	0757-0280	3		RESISTOR 1K 1% .125W F TC=0+-100	24546	C4-1/8-T0-1001-F
A1R103	0757-0416	7		RESISTOR 511 1% .125W F TC=0+-100	24546	C4-1/8-T0-511R-F
A1R104	0698-3152	8	1	RESISTOR 3.48K 1% .125W F TC=0+-100	24546	C4-1/8-T0-3481-F
A1R105	0757-0283	6		RESISTOR 2K 1% .125W F TC=0+-100	24546	C4-1/8-T0-2001-F
A1R106	0837-0220	1	1	THERMISTOR ROD 10K-OHM TC=-3.8%/C-DEG	28480	0837-0220
A1R107	1810-0368	3	1	NETWORK-RES 6-SIP10.0K OHM X 5	01121	206A103
A1R108	0698-0082	7		RESISTOR 464 1% .125W F TC=0+-100	24546	C4-1/8-T0-4640-F
A1R109	0757-0401	0		RESISTOR 100 1% .125W F TC=0+-100	24546	C4-1/8-T0-101-F
A1R110	0698-7284	5		RESISTOR 100K 1% .05W F TC=0+-100	24546	C3-1/8-T0-1003-F
A1S1	3101-2656	5	1	SS LIN SEL 90PC	28480	3101-2656
A1S2	3101-2644	1	1	SWITCH-PB DPDT ALTNG .5A 100VAC	28480	3101-2644
A1S3	3101-2453	0	1	SWITCH-TGL SUBMIN DPDT .02A 20VAC/DC PC	28480	3101-2453
A1T1	9100-2684	3	1	TRANSFORMER-POWER 115/230; 48/60 HZ	28480	9100-2684
A1TP1	1251-0600	0	10	CONNECTOR-SGL CONT PIN 1.14-MM-BSC-SZ SQ	28480	1251-0600
A1TP2	1251-0600	0		CONNECTOR-SGL CONT PIN 1.14-MM-BSC-SZ SQ	28480	1251-0600
A1TP3	1251-0600	0		CONNECTOR-SGL CONT PIN 1.14-MM-BSC-SZ SQ	28480	1251-0600
A1TP4	1251-0600	0		CONNECTOR-SGL CONT PIN 1.14-MM-BSC-SZ SQ	28480	1251-0600
A1TP5	1251-0600	0		CONNECTOR-SGL CONT PIN 1.14-MM-BSC-SZ SQ	28480	1251-0600
A1TP6	1251-0600	0		CONNECTOR-SGL CONT PIN 1.14-MM-BSC-SZ SQ	28480	1251-0600
A1TP7	1251-0600	0		CONNECTOR-SGL CONT PIN 1.14-MM-BSC-SZ SQ	28480	1251-0600
A1TP8	1251-0600	0		CONNECTOR-SGL CONT PIN 1.14-MM-BSC-SZ SQ	28480	1251-0600
A1TP9	1251-0600	0		CONNECTOR-SGL CONT PIN 1.14-MM-BSC-SZ SQ	28480	1251-0600
A1TP10	1251-0600	0		CONNECTOR-SGL CONT PIN 1.14-MM-BSC-SZ SQ	28480	1251-0600

See introduction to this section for ordering information
*Indicates factory selected value

Table 6-2. HP 5384A Replaceable Parts (Continued)

Reference Designation	HP Part Number	C D	Qty	Description	Mfr Code	Mfr Part Number
A1U1	1820-2312	2	1	IC MISC	28480	1820-2312
A1U2	1820-3572	8	1	IC-PCU W/ROM/RAM; 4MHZ	28480	1820-3572
A1U3	1820-3075	6	2	IC RCVR ECL/10KH LINE RCVR TPL	28480	1820-3075
A1U4	1820-3075	6	1	IC RCVR ECL/10KH LINE RCVR TPL	28480	1820-3075
A1U5	1820-3076	7	1	IC FF ECL/10KH D-M/S COM CLOCK DUAL	28480	1820-3076
A1U6	1858-0040	8	1	TRANSISTOR ARRAY 16-PIN PLSTC DIP	3L585	CA3127E
A1U7	1826-0544	0	1	IC V RGLTR-V-REF-FXD 2.5V 8-DIP-C PKG	28480	1826-0544
A1U7	1826-0904	6	1	IC-LM330T-5.0	28480	1826-0904
A1U9	1826-0428	9	1	IC 3524 MODULATOR 16-DIP-C	01295	SG3524J
A1U10	1826-0393	7	1	IC V RGLTR-ADJ-POS 1.2/37V TO-220 PKG	28480	1826-0393
A1U11	1858-0054	4	1	TRANSISTOR ARRAY 16-PIN PLSTC DIP	28480	1858-0054
A1U12	1826-0065	0	1	IC COMPARATOR PRCN 8-DIP-P PKG	S0545	UPC311C
A1U13	1820-1425	6	1	IC SCHMITT-TRIG TTL LS NAND QUAD 2-INP	01295	SN74LS132N
A1U14	1820-2096	9	1	IC CNTR TTL LS BIN DUAL 4-BIT	01295	SN74LS393N
A1U15	1820-1975	1	1	IC SHF-RGTR TTL LS NEG-EDGE-TRIG PRL-IN	01295	SN74LS165N
A1U16	1826-0501	9	1	IC MULTIPLXR 2-CHAN-ANLG TRIPLE 16-DIP-P	04713	MC14053BCP
A1W1	8120-4168	3	1	CABLE ASSY 16 PIN	28480	8120-4168
A1XF1	2110-0269	0	2	FUSEHOLDER-CLIP TYPE.25D-FUSE	28480	2110-0269
A1XF2	2110-0642	3	1	FUSEHOLDER-EXTR POST 6.3A 250V BAY CAP	28480	2110-0642
A1XU1	1200-0654	7	2	SOCKET-IC 40-CONT DIP DIP-SLDR	28480	1200-0654
A1XU2	1200-0654	7	1	SOCKET-IC 40-CONT DIP DIP-SLDR	28480	1200-0654
A1XW1	1200-0473	8	1	SOCKET-IC 16-CONT DIP DIP-SLDR	28480	1200-0473
A1Y1C	0410-0423	2	1	CRYSTAL-QUARTZ 10.000 MHZ	28480	0410-0423
R1	2100-2083	9	1	RESISTOR-VAR CONTROL CCP 20K 20% LIN	28480	2100-2083
W1	8120-1378	1	1	CABLE ASSY 18AWG 3-CNDCT JGK-JKT	28480	8120-1378
W2	8159-0005	0	1	RESISTOR-ZERO OHMS 22 AWG LEAD DIA	28480	8159-0005
W3	8150-0448	7	1	WIRE 24AWG BR 300V PVC 7X32 80C	28480	8150-0448
W4	8150-0449	8	1	WIRE 24AWG R 300V PVC 7X32 80C	28480	8150-0449
W5	8150-0450	1	1	WIRE 24AWG O 300V PVC 7X32 80C	28480	8150-0450
W6	8150-2846	3	1	WIRE 18AWG G/Y 300V PVC 19X30 105C	28480	8150-2846

See introduction to this section for ordering information
*Indicates factory selected value

HP 5384A and HP 5385A
Replaceable Parts

Table 6-3. HP 5384A With TCXO Replaceable Parts

Reference Designation	HP Part Number	C D	Qty	Description	Mfr Code	Mfr Part Number
A1	05384-60006	1	1	BOARD ASSEMBLY, MAIN (TCXO SERIES 2430)	28480	05384-60006
A1C1	0160-4704	9	1	CAPACITOR-FXD .01UF +-10% 500VDC CER	28480	0160-4704
A1C2	0160-5649	3	1	CAPACITOR-FXD 100PF +-5% 500VDC CER	28480	0160-5649
A1C3	0160-4385	2	1	CAPACITOR-FXD 15PF +-5% 200VDC CER 0+-30	28480	0160-4385
A1C4	0180-2816	2	1	CAPACITOR-FXD 68UF+-20% 10VDC TA	28480	0180-2816
A1C5	0180-0562	1	5	CAPACITOR-FXD 33UF+-20% 10VDC TA	56289	196D336X0010KA1
A1C6	0160-0573	2	1	CAPACITOR-FXD 4700PF +-20% 100VDC CER	28480	0160-0573
A1C7	0180-0562	1	1	CAPACITOR-FXD 33UF+-20% 10VDC TA	56289	196D336X0010KA1
A1C8	0160-0572	1	1	CAPACITOR-FXD 2200PF +-20% 100VDC CER	28480	0160-0572
A1C9	0160-3879	7	17	CAPACITOR-FXD .01UF +-20% 100VDC CER	28480	0160-3879
A1C10	0160-3879	7	1	CAPACITOR-FXD .01UF +-20% 100VDC CER	28480	0160-3879
A1C11	0160-4492	2	2	CAPACITOR-FXD 18PF +-5% 200VDC CER 0+-30	28480	0160-4492
A1C12	0160-4492	2	2	CAPACITOR-FXD 18PF +-5% 200VDC CER 0+-30	28480	0160-4492
A1C13	0180-0562	1	1	CAPACITOR-FXD 33UF+-20% 10VDC TA	56289	196D336X0010KA1
A1C14	0160-4423	9	1	CAPACITOR-FXD 470PF +-20% 500VDC CER	51642	200-500-X7R-471M
A1C15				NOT ASSIGNED		
A1C16	0180-2698	8	1	CAPACITOR-FXD 4.7UF+-10% 35VDC TA	28480	0180-2698
A1C17	0160-3879	7	7	CAPACITOR-FXD .01UF +-20% 100VDC CER	28480	0160-3879
A1C18	0160-3879	7	7	CAPACITOR-FXD .01UF +-20% 100VDC CER	28480	0160-3879
A1C19	0160-3879	7	7	CAPACITOR-FXD .01UF +-20% 100VDC CER	28480	0160-3879
A1C20	0160-3879	7	7	CAPACITOR-FXD .01UF +-20% 100VDC CER	28480	0160-3879
A1C21	0160-3879	7	7	CAPACITOR-FXD .01UF +-20% 100VDC CER	28480	0160-3879
A1C22*	0160-4040	6	1	CAPACITOR-FXD 1000PF +-5% 100VDC CER	28480	0160-4040
A1C23	0160-3879	7	7	CAPACITOR-FXD .01UF +-20% 100VDC CER	28480	0160-3879
A1C24				NOT ASSIGNED		
A1C25	0160-3879	7	7	CAPACITOR-FXD .01UF +-20% 100VDC CER	28480	0160-3879
A1C26	0160-3879	7	7	CAPACITOR-FXD .01UF +-20% 100VDC CER	28480	0160-3879
A1C27	0160-4554	7	8	CAPACITOR-FXD .01UF +-20% 50VDC CER	28480	0160-4554
A1C28	0160-0127	2	3	CAPACITOR-FXD 1UF +-20% 25VDC CER	28480	0160-0127
A1C29	0180-3276	0	2	CAPACITOR-FXD 2200UF+100-10% 25VDC AL	28480	0180-3276
A1C30	0180-3276	0	2	CAPACITOR-FXD 2200UF+100-10% 25VDC AL	28480	0180-3276
A1C31	0180-0228	6	1	CAPACITOR-FXD 22UF+-10% 15VDC TA	56289	150D226X9015B2
A1C32	0160-4557	0	1	CAPACITOR-FXD .1UF +-20% 50VDC CER	16299	CAC04X7R104M050A
A1C33	0160-3879	7	7	CAPACITOR-FXD .01UF +-20% 100VDC CER	28480	0160-3879
A1C34	0160-4819	7	2	CAPACITOR-FXD 2200PF +-5% 100VDC CER	28480	0160-4819
A1C35	0160-4822	2	3	CAPACITOR-FXD 1000PF +-5% 100VDC CER	28480	0160-4822
A1C36	0180-3279	3	1	CAPACITOR-FXD 390UF+100-10% 12VDC AL	28480	0180-3279
A1C37	0160-3879	7	7	CAPACITOR-FXD .01UF +-20% 100VDC CER	28480	0160-3879
A1C38	0160-3879	7	7	CAPACITOR-FXD .01UF +-20% 100VDC CER	28480	0160-3879
A1C39	0160-3879	7	7	CAPACITOR-FXD .01UF +-20% 100VDC CER	28480	0160-3879
A1C40	0180-0291	3	3	CAPACITOR-FXD 1UF+-10% 35VDC TA	56289	150D105X9035A2
A1C41	0160-4554	7	7	CAPACITOR-FXD .01UF +-20% 50VDC CER	28480	0160-4554
A1C42	0160-4554	7	7	CAPACITOR-FXD .01UF +-20% 50VDC CER	28480	0160-4554
A1C43	0180-0291	3	3	CAPACITOR-FXD 1UF+-10% 35VDC TA	56289	150D105X9035A2
A1C44	0180-0291	3	3	CAPACITOR-FXD 1UF+-10% 35VDC TA	56289	150D105X9035A2
A1C45	0160-3879	7	7	CAPACITOR-FXD .01UF +-20% 100VDC CER	28480	0160-3879
A1C46	0160-4822	2	2	CAPACITOR-FXD 1000PF +-5% 100VDC CER	28480	0160-4822
A1C47	0160-4554	7	7	CAPACITOR-FXD .01UF +-20% 50VDC CER	28480	0160-4554
A1C48	0160-4822	2	2	CAPACITOR-FXD 1000PF +-5% 100VDC CER	28480	0160-4822
A1C49	0160-4554	7	7	CAPACITOR-FXD .01UF +-20% 50VDC CER	28480	0160-4554
A1C50	0160-4810	8	1	CAPACITOR-FXD 330PF +-5% 100VDC CER	28480	0160-4810
A1C51	0160-4554	7	7	CAPACITOR-FXD .01UF +-20% 50VDC CER	28480	0160-4554
A1C52	0160-4554	7	7	CAPACITOR-FXD .01UF +-20% 50VDC CER	28480	0160-4554
A1C53	0160-0127	2	2	CAPACITOR-FXD 1UF +-20% 25VDC CER	28480	0160-0127
A1C54	0180-0418	6	1	CAPACITOR-FXD 1UF+-20% 35VDC TA	28480	0180-0418
A1C55	0160-4808	4	3	CAPACITOR-FXD 470PF +-5% 100VDC CER	28480	0160-4808
A1C56	0160-4808	4	4	CAPACITOR-FXD 470PF +-5% 100VDC CER	28480	0160-4808
A1C57	0160-4808	4	4	CAPACITOR-FXD 470PF +-5% 100VDC CER	28480	0160-4808
A1C58	0160-4554	7	7	CAPACITOR-FXD .01UF +-20% 50VDC CER	28480	0160-4554
A1C59	0160-3879	7	7	CAPACITOR-FXD .01UF +-20% 100VDC CER	28480	0160-3879
A1C60	0160-3878	6	1	CAPACITOR-FXD 1000PF +-20% 100VDC CER	28480	0160-3878

See introduction to this section for ordering information
*Indicates factory selected value

Table 6-3. HP 5384A With TCXO Replaceable Parts (Continued)

Reference Designation	HP Part Number	C D	Qty	Description	Mfr Code	Mfr Part Number
A1C61- A1C66 A1C67 A1C68 A1C69	0160-3879	7		NOT ASSIGNED CAPACITOR-FXD .01UF +-20% 100VDC CER	28480	0160-3879
A1C70 A1C71 A1C72 A1C73 A1C74	0160-4819 0160-4805 0180-0562	7 1 1	1	CAPACITOR-FXD 2200PF +-5% 100VDC CER CAPACITOR-FXD 47PF +-5% 100VDC CER 0+-30 CAPACITOR-FXD 33UF+-20% 10VDC TA NOT ASSIGNED NOT ASSIGNED	28480 28480 56289	0160-4819 0160-4805 196D336X0010KA1
A1C75	0180-0562	1		CAPACITOR-FXD 33UF+-20% 10VDC TA	56289	196D336X0010KA1
A1CR1 A1CR2 A1CR3 A1CR4 A1CR5	1901-0050 1901-0376 1901-0376 1901-0535 1901-0639	3 6 6 9 4	13 2	DIODE-SWITCHING 80V 200MA 2NS DO-35 DIODE-GEN PRP 35V 50MA DO-35 DIODE-GEN PRP 35V 50MA DO-35 DIODE-SM SIG SCHOTTKY DIODE-PIN	28480 28480 28480 28480 28480	1901-0050 1901-0376 1901-0376 1901-0535 5082-3080
A1CR6 A1CR7 A1CR8 A1CR9 A1CR10	1901-0050 1901-0050 1906-0096 1884-0221 1902-3234	3 3 7 2 3	1	DIODE-SWITCHING 80V 200MA 2NS DO-35 DIODE-SWITCHING 80V 200MA 2NS DO-35 DIODE-FW BRDG 200V 2A THYRISTOR-SCR VRRM=300 DIODE-ZNR 19.6V 5% DO-35 PD=.4W	28480 28480 04713 04713 28480	1901-0050 1901-0050 MDA202 MCR106-5 1902-3234
A1CR11 A1CR12 A1CR13 A1CR14 A1CR15	1901-0050 1901-0782 1902-3110 1901-0782 1901-0050	3 8 4 8 3	2 1	DIODE-SWITCHING 80V 200MA 2NS DO-35 DIODE-SCHOTTKY 1N5821 30V 3A DIODE-ZNR 5.9V 2% DO-35 PD=.4W TC=+.017% DIODE-SCHOTTKY 1N5821 30V 3A DIODE-SWITCHING 80V 200MA 2NS DO-35	28480 04713 28480 04713 28480	1901-0050 1N5821 1902-3110 1N5821 1901-0050
A1CR16 A1CR17 A1CR18 A1CR19 A1CR20	1901-0050 1901-0050 1901-0050 1901-0050 1901-0050	3 3 3 3 3		DIODE-SWITCHING 80V 200MA 2NS DO-35 DIODE-SWITCHING 80V 200MA 2NS DO-35 DIODE-SWITCHING 80V 200MA 2NS DO-35 DIODE-SWITCHING 80V 200MA 2NS DO-35 DIODE-SWITCHING 80V 200MA 2NS DO-35	28480 28480 28480 28480 28480	1901-0050 1901-0050 1901-0050 1901-0050 1901-0050
A1CR21 A1CR22 A1CR23	1901-0050 1901-0050 1901-0050	3 3 3		DIODE-SWITCHING 80V 200MA 2NS DO-35 DIODE-SWITCHING 80V 200MA 2NS DO-35 DIODE-SWITCHING 80V 200MA 2NS DO-35	28480 28480 28480	1901-0050 1901-0050 1901-0050
A1E1	9170-0029	3	1	CORE-SHIELDING BEAD	28480	9170-0029
A1F1 A1F1 A1F2	2110-0201 2110-0565 2110-0002	0 9 9	1 1 1	FUSE .25A 250V TD 1.25X.25 UL FUSEHOLDER CAP 12A MAX FOR UL FUSE 2A 250V NTD 1.25X.25 UL	28480 28480 75915	2110-0201 2110-0565 312002
A1J1 A1J2 A1J3 A1J4 A1J5	1250-1782 1250-1782 1251-4743 1251-8261 1250-1842	9 9 0 5 2	2	CONNECTOR-RF BNC FEM PCH-PNL 50-OHM CONNECTOR-RF BNC FEM PCH-PNL 50-OHM CONNECTOR-AC PUR HP-9 MALE REC-FLG THRM P JACK POWER PCB MT BNC RTANG PC MNT	28480 28480 28480 28480 28480	1250-1782 1250-1782 1251-4743 1251-8261 1250-1842
A1J6 A1J7 A1J8 A1J9	1251-8304 1251-7684 1251-8139	7 4 6	1	CONN-POST TYPE .100-PIN-SPCG 8-CONT NOT ASSIGNED CABLE ASSY 14 POST CONN-POST TYPE .100-PIN-SPCG 14-CONT	28480 28480 28480	1251-8304 1251-7684 1251-8139
A1K1	0490-1317	3	1	RELAY-REED 1C 250MA 200VDC 5VDC-COIL 3VA	28480	0490-1317
A1L1 A1L2 A1L3 A1L4 A1L6	9140-0718 9100-1788 9100-1788 9100-2562 9100-1788	4 6 6 6 6	1 4	INDUCTOR-FIXED NORM IND: 230UH à 1.5ADC CORE-FERRITE CHOKE-WIDEBAND; IMP:>680 CORE-FERRITE CHOKE-WIDEBAND; IMP:>680 INDUCTOR RF-CH-MLD 100UH 10% CORE-FERRITE CHOKE-WIDEBAND; IMP:>680	28480 28480 28480 28480 28480	9140-0718 9100-1788 9100-1788 9100-2562 9100-1788
A1L7	9100-1788	6		CORE-FERRITE CHOKE-WIDEBAND; IMP:>680	28480	9100-1788
A1Q1 A1Q2 A1Q3 A1Q4 A1Q5	1854-0215 1855-0327 1853-0354 1855-0414 1854-0215	1 8 7 4 1	3	TRANSISTOR NPN SI PD=350MW FT=300MHZ TRANSISTOR J-FET 2N4416 N-CHAN D-MODE TRANSISTOR PNP SI T0-92 PD=350MW TRANSISTOR J-FET 2N4393 N-CHAN D-MODE TRANSISTOR NPN SI PD=350MW FT=300MHZ	04713 01295 28480 04713 04713	2N3904 2N4416 1853-0354 2N4393 2N3904
A1Q6 A1Q7 A1Q8 A1Q9 A1Q10	1854-0574 1854-0215 1853-0015 1853-0015 1853-0363	5 1 7 7 8	1 2	TRANSISTOR NPN SI PD=500MW FT=125MHZ TRANSISTOR NPN SI PD=350MW FT=300MHZ TRANSISTOR PNP SI PD=200MW FT=500MHZ TRANSISTOR PNP SI PD=200MW FT=500MHZ TRANSISTOR PNP SI PD=50W FT=20MHZ	28480 04713 28480 28480 03508	1854-0574 2N3904 1853-0015 1853-0015 X45H281

See introduction to this section for ordering information
*Indicates factory selected value

HP 5384A and HP 5385A
Replaceable Parts

Table 6-3. HP 5384A With TCXO Replaceable Parts (Continued)

Reference Designation	HP Part Number	C D	Qty	Description	Mfr Code	Mfr Part Number
A1Q11	1854-0013	7	1	TRANSISTOR NPN 2N2218A SI TO-5 PD=800MW	04713	2N2218A
A1Q12	1854-0477	7	1	TRANSISTOR NPN 2N2222A SI TO-18 PD=500MW	04713	2N2222A
A1R1	0698-8827	4	2	RESISTOR 1M 1% .125W F TC=0+-100	28480	0698-8827
A1R2	0757-0706	8	3	RESISTOR 51.1 1% .25W F TC=0+-100	24546	C5-1/4-T0-51R1-F
A1R3	0698-8827	4	2	RESISTOR 1M 1% .125W F TC=0+-100	28480	0698-8827
A1R4	0699-0071	6	2	RESISTOR 4.64M 1% .125W F TC=0+-100	28480	0699-0071
A1R5	0698-7276	5	1	RESISTOR 46.4K 1% .05W F TC=0+-100	24546	C3-1/8-T0-4642-F
A1R6	0757-0346	2	2	RESISTOR 10 1% .125W F TC=0+-100	24546	C4-1/8-T0-10R0-F
A1R7	0757-0421	4	3	RESISTOR 825 1% .125W F TC=0+-100	24546	C4-1/8-T0-825R-F
A1R8	0698-3445	2	2	RESISTOR 348 1% .125W F TC=0+-100	24546	C4-1/8-T0-348R-F
A1R9	0698-7236	7	3	RESISTOR 1K 1% .05W F TC=0+-100	24546	C3-1/8-T0-1001-F
A1R10	0698-7233	4	1	RESISTOR 750 1% .05W F TC=0+-100	24546	C3-1/8-T0-750R-F
A1R11	0698-7283	4	1	RESISTOR 90.9K 1% .05W F TC=0+-100	24546	C3-1/8-T0-9092-F
A1R12	0698-8812	7	1	RESISTOR 1 1% .125W F TC=0+-100	28480	0698-8812
A1R13	0698-3136	8	1	RESISTOR 17.8K 1% .125W F TC=0+-100	24546	C4-1/8-T0-1782-F
A1R14	0698-7244	7	2	RESISTOR 2.15K 1% .05W F TC=0+-100	24546	C3-1/8-T0-2151-F
A1R15	0698-3447	4	3	RESISTOR 422 1% .125W F TC=0+-100	24546	C4-1/8-T0-422R-F
A1R16	0698-3447	4	1	RESISTOR 422 1% .125W F TC=0+-100	24546	C4-1/8-T0-422R-F
A1R17	1810-0541	4	1	NETWORK-RES 6-SIP MULTI-VALUE	28480	1810-0541
A1R18	1810-0219	3	1	NETWORK-RES 8-SIP220.0 OHM X 4	01121	208B221
A1R19	0698-7220	9	3	RESISTOR 215 1% .05W F TC=0+-100	24546	C3-1/8-T0-215R-F
A1R20	0698-7220	9	3	RESISTOR 215 1% .05W F TC=0+-100	24546	C3-1/8-T0-215R-F
A1R21	0698-7249	2	2	RESISTOR 3.48K 1% .05W F TC=0+-100	24546	C3-1/8-T0-3481-F
A1R22	0757-0283	6	3	RESISTOR 2K 1% .125W F TC=0+-100	24546	C4-1/8-T0-2001-F
A1R23	0698-7267	4	1	RESISTOR 19.6K 1% .05W F TC=0+-100	24546	C3-1/8-T0-1962-F
A1R24	0698-7210	7	1	RESISTOR 82.5 1% .05W F TC=0+-100	24546	C3-1/8-T0-82R5-F
A1R25	0757-0706	8	3	RESISTOR 51.1 1% .25W F TC=0+-100	24546	C5-1/4-T0-51R1-F
A1R26	0757-0706	8	3	RESISTOR 51.1 1% .25W F TC=0+-100	24546	C5-1/4-T0-51R1-F
A1R27	0698-7244	7	2	RESISTOR 2.15K 1% .05W F TC=0+-100	24546	C3-1/8-T0-2151-F
A1R28	0698-7249	2	2	RESISTOR 3.48K 1% .05W F TC=0+-100	24546	C3-1/8-T0-3481-F
A1R29	0698-7236	7	3	RESISTOR 1K 1% .05W F TC=0+-100	24546	C3-1/8-T0-1001-F
A1R30	0698-3437	2	2	RESISTOR 133 1% .125W F TC=0+-100	24546	C4-1/8-T0-133R-F
A1R31	0698-3437	2	2	RESISTOR 133 1% .125W F TC=0+-100	24546	C4-1/8-T0-133R-F
A1R32	2100-0558	9	2	RESISTOR-TRMR 20K 10% C TOP-ADJ 1-TRN	28480	2100-0558
A1R33	0698-3442	9	1	RESISTOR 237 1% .125W F TC=0+-100	24546	C4-1/8-T0-237R-F
A1R34	0698-7265	2	1	RESISTOR 16.2K 1% .05W F TC=0+-100	24546	C3-1/8-T0-1622-F
A1R35	0698-7236	7	3	RESISTOR 1K 1% .05W F TC=0+-100	24546	C3-1/8-T0-1001-F
A1R36	0698-7229	8	6	RESISTOR 511 1% .05W F TC=0+-100	24546	C3-1/8-T0-511R-F
A1R37	0698-7205	0	3	RESISTOR 51.1 1% .05W F TC=0+-100	24546	C3-1/8-T0-51R1-F
A1R38	0698-7205	0	3	RESISTOR 51.1 1% .05W F TC=0+-100	24546	C3-1/8-T0-51R1-F
A1R39	0698-7229	8	6	RESISTOR 511 1% .05W F TC=0+-100	24546	C3-1/8-T0-511R-F
A1R40	0698-7220	9	3	RESISTOR 215 1% .05W F TC=0+-100	24546	C3-1/8-T0-215R-F
A1R41	0698-3156	2	2	RESISTOR 14.7K 1% .125W F TC=0+-100	24546	C4-1/8-T0-1472-F
A1R42	0698-7229	8	6	RESISTOR 511 1% .05W F TC=0+-100	24546	C3-1/8-T0-511R-F
A1R43	2100-0558	9	2	RESISTOR-TRMR 20K 10% C TOP-ADJ 1-TRN	28480	2100-0558
A1R44	0698-7284	5	1	RESISTOR 100K 1% .05W F TC=0+-100	24546	C3-1/8-T0-1003-F
A1R45	0698-7209	4	1	RESISTOR 75 1% .05W F TC=0+-100	24546	C3-1/8-T0-75R0-F
A1R46	0698-7205	0	3	RESISTOR 51.1 1% .05W F TC=0+-100	24546	C3-1/8-T0-51R1-F
A1R47	0698-7229	8	6	RESISTOR 511 1% .05W F TC=0+-100	24546	C3-1/8-T0-511R-F
A1R48	0698-7243	6	1	RESISTOR 1.96K 1% .05W F TC=0+-100	24546	C3-1/8-T0-1961-F
A1R49	1810-0488	8	1	NETWORK-RES 8-SIP4.7K OHM X 4	28480	1810-0488
A1R50	0812-0021	8	1	RESISTOR .47 5% 3W PW TC=0+-90	91637	CW2B1-3-T2-47/100-J
A1R51	0698-7229	8	6	RESISTOR 511 1% .05W F TC=0+-100	24546	C3-1/8-T0-511R-F
A1R52	0757-0394	0	3	RESISTOR 51.1 1% .125W F TC=0+-100	24546	C4-1/8-T0-51R1-F
A1R53	0698-3132	4	3	RESISTOR 261 1% .125W F TC=0+-100	24546	C4-1/8-T0-2610-F
A1R54	0757-1093	8	2	RESISTOR 3K 1% .125W F TC=0+-100	24546	C4-1/8-T0-3001-F
A1R55	0757-0465	6	2	RESISTOR 100K 1% .125W F TC=0+-100	24546	C4-1/8-T0-1003-F
A1R56	0757-0407	6	1	RESISTOR 200 1% .125W F TC=0+-100	24546	C4-1/8-T0-201-F
A1R57	0757-0289	2	1	RESISTOR 13.3K 1% .125W F TC=0+-100	19701	MF4C1/8-T0-1332-F
A1R58	0757-0399	5	1	RESISTOR 82.5 1% .125W F TC=0+-100	24546	C4-1/8-T0-82R5-F
A1R59	0757-0416	7	4	RESISTOR 511 1% .125W F TC=0+-100	24546	C4-1/8-T0-511R-F
A1R60	0757-0346	2	2	RESISTOR 10 1% .125W F TC=0+-100	24546	C4-1/8-T0-10R0-F
A1R61	0698-3398	4	1	RESISTOR 46.4 1% .5W F TC=0+-100	28480	0698-3398
A1R62	0757-0200	7	2	RESISTOR 5.62K 1% .125W F TC=0+-100	24546	C4-1/8-T0-5621-F
A1R63	0757-0200	7	2	RESISTOR 5.62K 1% .125W F TC=0+-100	24546	C4-1/8-T0-5621-F
A1R64	0699-0071	6	2	RESISTOR 4.64M 1% .125W F TC=0+-100	28480	0699-0071
A1R65	1810-0370	7	1	NETWORK-RES 8-SIP220.0 OHM X 7	01121	208A221

See introduction to this section for ordering information
*Indicates factory selected value

Table 6-3. HP 5384A With TCXO Replaceable Parts (Continued)

Reference Designation	HP Part Number	C D	Qty	Description	Mfr Code	Mfr Part Number
A1R66	0757-0394	0		RESISTOR 51.1 1% .125W F TC=0+-100	24546	C4-1/8-T0-51R1-F
A1R67	0757-0394	0		RESISTOR 51.1 1% .125W F TC=0+-100	24546	C4-1/8-T0-51R1-F
A1R68	0698-3441	8	2	RESISTOR 215 1% .125W F TC=0+-100	24546	C4-1/8-T0-215R-F
A1R69	0698-3441	8		RESISTOR 215 1% .125W F TC=0 100	24546	C4-1/8-T0-215R-F
A1R70	0698-7212	9	2	RESISTOR 100 1% .05W F TC=0+-100	24546	C3-1/8-T0-100R-F
A1R71	0698-7212	9		RESISTOR 100 1% .05W F TC=0+-100	24546	C3-1/8-T0-100R-F
A1R72	0698-3156	2		RESISTOR 14.7K 1% .125W F TC=0+-100	24546	C4-1/8-T0-1472-F
A1R73	0698-7197	9	1	RESISTOR 350 1% .05W F TC=0+-100	24546	C3-1/8-T0-23R7-F
A1R74	0698-7219	6	1	RESISTOR 196 1% .05W F TC=0+-100	24546	C3-1/8-T0-196R-F
A1R75	0757-0420	3	2	RESISTOR 750 1% .125W F TC=0+-100	24546	C4-1/8-T0-751-F
A1R76	0757-0419	0	1	RESISTOR 681 1% .125W F TC=0+-100	24546	C4-1/8-T0-681R-F
A1R77	2100-0554	5	1	RESISTOR-TRMR 500 10% C TOP-ADJ 1-TRN	28480	2100-0554
A1R78	0757-0465	6		RESISTOR 100K 1% .125W F TC=0+-100	24546	C4-1/8-T0-1003-F
A1R79	0757-0420	3		RESISTOR 750 1% .125W F TC=0+-100	24546	C4-1/8-T0-751-F
A1R80	0698-0082	7	5	RESISTOR 464 1% .125W F TC=0+-100	24546	C4-1/8-T0-4640-F
A1R81	0698-0082	7		RESISTOR 464 1% .125W F TC=0+-100	24546	C4-1/8-T0-4640-F
A1R82	0757-0283	6		RESISTOR 2K 1% .125W F TC=0+-100	24546	C4-1/8-T0-2001-F
A1R83	0757-1093	8		RESISTOR 3K 1% .125W F TC=0+-100	24546	C4-1/8-T0-3001-F
A1R84	0698-0082	7		RESISTOR 464 1% .125W F TC=0+-100	24546	C4-1/8-T0-4640-F
A1R85	0698-0082	7		RESISTOR 464 1% .125W F TC=0+-100	24546	C4-1/8-T0-4640-F
A1R86	0698-3445	2		RESISTOR 348 1% .125W F TC=0+-100	24546	C4-1/8-T0-348R-F
A1R87	0757-0421	4		RESISTOR 825 1% .125W F TC=0+-100	24546	C4-1/8-T0-825R-F
A1R88	0757-0421	4		RESISTOR 825 1% .125W F TC=0+-100	24546	C4-1/8-T0-825R-F
A1R89	0698-3460	1	1	RESISTOR 422K 1% .125W F TC=0+-100	28480	0698-3460
A1R90	0757-0416	7		RESISTOR 511 1% .125W F TC=0+-100	24546	C4-1/8-T0-511R-F
A1R91	0698-3132	4		RESISTOR 261 1% .125W F TC=0+-100	24546	C4-1/8-T0-2610-F
A1R92	0698-3132	4		RESISTOR 261 1% .125W F TC=0+-100	24546	C4-1/8-T0-2610-F
A1R93	0757-0280	3	2	RESISTOR 1K 1% .125W F TC=0+-100	24546	C4-1/8-T0-1001-F
A1R94	0698-7229	8		RESISTOR 511 1% .05W F TC=0+-100	24546	C3-1/8-T0-511R-F
A1R95	0757-0416	7		RESISTOR 511 1% .125W F TC=0+-100	24546	C4-1/8-T0-511R-F
A1R96- A1R100				NOT ASSIGNED		
A1R101	0698-3447	4		RESISTOR 422 1% .125W F TC=0+-100	24546	C4-1/8-T0-422R-F
A1R102	0757-0280	3		RESISTOR 1K 1% .125W F TC=0+-100	24546	C4-1/8-T0-1001-F
A1R103	0757-0416	7		RESISTOR 511 1% .125W F TC=0+-100	24546	C4-1/8-T0-511R-F
A1R104	0698-3152	8	1	RESISTOR 3.48K 1% .125W F TC=0+-100	24546	C4-1/8-T0-3481-F
A1R105	0757-0283	6		RESISTOR 2K 1% .125W F TC=0+-100	24546	C4-1/8-T0-2001-F
A1R106	0837-0220	1	1	THERMISTOR ROD 10K-OHM TC=-3.83%/C-DEG	28480	0837-0220
A1R107	1810-0368	3	1	NETWORK-RES 6-SIP10.0K OHM X 5	01121	206A103
A1R108	0698-0082	7		RESISTOR 464 1% .125W F TC=0+-100	24546	C4-1/8-T0-4640-F
A1R109	0757-0401	0	1	RESISTOR 100 1% .125W F TC=0+-100	24546	C4-1/8-T0-101-F
A1S1	3101-2656	5	1	SS LIN SEL 90PC	28480	3101-2656
A1S2	3101-2644	1	1	SWITCH-PB DPDT ALTNG .5A 100VAC	28480	3101-2644
A1S3	3101-2453	0	1	SWITCH-TGL SUBMIN DPDT .02A 20VAC/DC PC	28480	3101-2453
A1T1	9100-2684	3	1	TRANSFORMER-POWER 115/230; 48/60 HZ	28480	9100-2684
A1TP1	1251-0600	0	10	CONNECTOR-SGL CONT PIN 1.14-MM-BSC-SZ SQ	28480	1251-0600
A1TP2	1251-0600	0		CONNECTOR-SGL CONT PIN 1.14-MM-BSC-SZ SQ	28480	1251-0600
A1TP3	1251-0600	0		CONNECTOR-SGL CONT PIN 1.14-MM-BSC-SZ SQ	28480	1251-0600
A1TP4	1251-0600	0		CONNECTOR-SGL CONT PIN 1.14-MM-BSC-SZ SQ	28480	1251-0600
A1TP5	1251-0600	0		CONNECTOR-SGL CONT PIN 1.14-MM-BSC-SZ SQ	28480	1251-0600
A1TP6	1251-0600	0		CONNECTOR-SGL CONT PIN 1.14-MM-BSC-SZ SQ	28480	1251-0600
A1TP7	1251-0600	0		CONNECTOR-SGL CONT PIN 1.14-MM-BSC-SZ SQ	28480	1251-0600
A1TP8	1251-0600	0		CONNECTOR-SGL CONT PIN 1.14-MM-BSC-SZ SQ	28480	1251-0600
A1TP9	1251-0600	0		CONNECTOR-SGL CONT PIN 1.14-MM-BSC-SZ SQ	28480	1251-0600
A1TP10	1251-0600	0		CONNECTOR-SGL CONT PIN 1.14-MM-BSC-SZ SQ	28480	1251-0600
A1U1	1820-2312	2	1	IC MISC	28480	1820-2312
A1U2	1820-3572	8	1	IC-MCU W/ROM/RAM; 4MHZ	28480	1820-3572
A1U3	1820-3075	6	2	IC RCVR ECL/10KH LINE RCVR TPL	28480	1820-3075
A1U4	1820-3075	6		IC RCVR ECL/10KH LINE RCVR TPL	28480	1820-3075
A1U5	1820-3076	7	1	IC FF ECL/10KH D-M/S COM CLOCK DUAL	28480	1820-3076
A1U6	1858-0040	8	1	TRANSISTOR ARRAY 16-PIN PLSTC DIP	3L585	CA3127E
A1U7	1826-0904	6	1	IC-LM330T-5.0	28480	1826-0904
A1U8	1826-0544	0	1	IC V RGLTR-V-REF-FXD 2.5V 8-DIP-C PKG	28480	1826-0544
A1U9	1826-0428	9	1	IC 3524 MODULATOR 16-DIP-C	01295	SG3524J
A1U10	1826-0393	7	1	IC V RGLTR-ADJ-POS 1.2/37V T0-220 PKG	28480	1826-0393

See introduction to this section for ordering information
*Indicates factory selected value

HP 5384A and HP 5385A
Replaceable Parts

Table 6-3. HP 5384A With TCXO Replaceable Parts (Continued)

Reference Designation	HP Part Number	C D	Qty	Description	Mfr Code	Mfr Part Number
A1U11	1858-0054	4	1	TRANSISTOR ARRAY 16-PIN PLSTC DIP	28480	1858-0054
A1U12	1826-0065	0	1	IC COMPARATOR PRCN 8-DIP-P PKG	S0545	UPC311C
A1U13	1820-1425	6	1	IC SCHMITT-TRIG TTL LS NAND QUAD 2-INP	01295	SN74LS132N
A1U14	1820-2096	9	1	IC CNTR TTL LS BIN DUAL 4-BIT	01295	SN74LS393N
A1U15	1820-1975	1	1	IC SHF-RGTR TTL LS NEG-EDGE-TRIG PRL-IN	01295	SN74LS165N
A1U16	1826-0501	9	1	IC MULTIPLXR 2-CHAN-ANLG TRIPLE 16-DIP-P	04713	MC14053BCP
A1W1	8120-4168	3	1	CABLE ASSY 5384A	28480	8120-4168
A1XF1	2110-0269	0	1	FUSEHOLDER-CLIP TYPE.25D-FUSE	28480	2110-0269
A1XF2	2110-0642	3	1	FUSEHOLDER-EXTR POST 6.3A 250V BAY CAP	28480	2110-0642
A1XU1	1200-0654	7	2	SOCKET-IC 40-CONT DIP DIP-SLDR	28480	1200-0654
A1XU2	1200-0654	7		SOCKET-IC 40-CONT DIP DIP-SLDR	28480	1200-0654
A1XW1	1200-0473	8	1	SOCKET-IC 16-CONT DIP DIP-SLDR	28480	1200-0473
A1Y1B	0960-0612	6	1	CRYSTAL-OSCILLATOR 10.0 MHZ; 0-5S DEG C	28480	0960-0612
W1	8120-1378	1	1	CABLE ASSY 18AWG 3-CNDCT JGK-JKT	28480	8120-1378
W3	8150-0448	7	1	WIRE 24AWG BR 300V PVC 7X32 80C	28480	8150-0448
W4	8150-0449	8	1	WIRE 24AWG R 300V PVC 7X32 80C	28480	8150-0449
W5	8150-0450	1	1	WIRE 24AWG O 300V PVC 7X32 80C	28480	8150-0450
W6	8150-2846	3	1	WIRE 18AWG G/Y 300V PVC 19X30 105C	28480	8150-2846

See introduction to this section for ordering information
*Indicates factory selected value

Table 6-4. HP 5384A With Oven Oscillator Replaceable Parts

Reference Designation	HP Part Number	C D	Qty	Description	Mfr Code	Mfr Part Number
A1	05384-60007	2	1	BOARD ASSEMBLY (OVEN OSC) (SERIES 2430)	28480	05384-60007
A1C1	0160-4704	9	1	CAPACITOR-FXD .01UF +-10% 500VDC CER	28480	0160-4704
A1C2	0160-5649	3	1	CAPACITOR-FXD 100PF +-5% 500VDC CER	28480	0160-5649
A1C3	0160-4385	2	1	CAPACITOR-FXD 15PF +-5% 200VDC CER 0+-30	28480	0160-4385
A1C4	0180-2816	2	1	CAPACITOR-FXD 68UF+-20% 10VDC TA	28480	0180-2816
A1C5	0180-0562	1	5	CAPACITOR-FXD 33UF+-20% 10VDC TA	56289	196D336X0010KA1
A1C6	0160-0573	2	1	CAPACITOR-FXD 4700PF +-20% 100VDC CER	28480	0160-0573
A1C7	0180-0562	1		CAPACITOR-FXD 33UF+-20% 10VDC TA	56289	196D336X0010KA1
A1C8	0160-0572	1	1	CAPACITOR-FXD 2200PF +-20% 100VDC CER	28480	0160-0572
A1C9	0160-3879	7	17	CAPACITOR-FXD .01UF +-20% 100VDC CER	28480	0160-3879
A1C10	0160-3879	7		CAPACITOR-FXD .01UF +-20% 100VDC CER	28480	0160-3879
A1C11	0160-4492	2	2	CAPACITOR-FXD 18PF +-5% 200VDC CER 0+-30	28480	0160-4492
A1C12	0160-4492	2		CAPACITOR-FXD 18PF +-5% 200VDC CER 0+-30	28480	0160-4492
A1C13	0180-0562	1		CAPACITOR-FXD 33UF+-20% 10VDC TA	56289	196D336X0010KA1
A1C14	0160-4423	9	1	CAPACITOR-FXD 470PF +-20% 500VDC CER	51642	200-500-X7R-471M
A1C15				NOT ASSIGNED		
A1C16	0180-2698	8	1	CAPACITOR-FXD 4.7UF+-10% 35VDC TA	28480	0180-2698
A1C17	0160-3879	7		CAPACITOR-FXD .01UF +-20% 100VDC CER	28480	0160-3879
A1C18	0160-3879	7		CAPACITOR-FXD .01UF +-20% 100VDC CER	28480	0160-3879
A1C19	0160-3879	7		CAPACITOR-FXD .01UF +-20% 100VDC CER	28480	0160-3879
A1C20	0160-3879	7		CAPACITOR-FXD .01UF +-20% 100VDC CER	28480	0160-3879
A1C21	0160-3879	7		CAPACITOR-FXD .01UF +-20% 100VDC CER	28480	0160-3879
A1C22*	0160-4040	6	1	CAPACITOR-FXD 1000PF +-5% 100VDC CER	28480	0160-4040
A1C23	0160-3879	7		CAPACITOR-FXD .01UF +-20% 100VDC CER	28480	0160-3879
A1C24				NOT ASSIGNED		
A1C25	0160-3879	7		CAPACITOR-FXD .01UF +-20% 100VDC CER	28480	0160-3879
A1C26	0160-3879	7		CAPACITOR-FXD .01UF +-20% 100VDC CER	28480	0160-3879
A1C27	0160-4554	7	9	CAPACITOR-FXD .01UF +-20% 50VDC CER	28480	0160-4554
A1C28	0160-0127	2	3	CAPACITOR-FXD 1UF +-20% 25VDC CER	28480	0160-0127
A1C29	0180-3276	0	2	CAPACITOR-FXD 2200UF+100-10% 25VDC AL	28480	0180-3276
A1C30	0180-3276	0		CAPACITOR-FXD 2200UF+100-10% 25VDC AL	28480	0180-3276
A1C31	0180-0228	6	1	CAPACITOR-FXD 22UF+-10% 15VDC TA	56289	150D226X9015B2
A1C32	0160-4554	0	1	CAPACITOR-FXD .1UF +-20% 50VDC CER	16299	CAC04X7R104M050A
A1C33	0160-3879	7		CAPACITOR-FXD .01UF +-20% 100VDC CER	28480	0160-3879
A1C34	0160-4819	7	2	CAPACITOR-FXD 2200PF +-5% 100VDC CER	28480	0160-4819
A1C35	0160-4822	2	3	CAPACITOR-FXD 1000PF +-5% 100VDC CER	28480	0160-4822
A1C36	0180-3279	3	1	CAPACITOR-FXD 390UF+100-10% 12VDC AL	28480	0180-3279
A1C37	0160-3879	7		CAPACITOR-FXD .01UF +-20% 100VDC CER	28480	0160-3879
A1C38	0160-3879	7		CAPACITOR-FXD .01UF +-20% 100VDC CER	28480	0160-3879
A1C39	0160-3879	7		CAPACITOR-FXD .01UF +-20% 100VDC CER	28480	0160-3879
A1C40	0180-0291	3	3	CAPACITOR-FXD 1UF+-10% 35VDC TA	56289	150D105X9035A2
A1C41	0160-4554	7		CAPACITOR-FXD .01UF +-20% 50VDC CER	28480	0160-4554
A1C42	0160-4554	7		CAPACITOR-FXD .01UF +-20% 50VDC CER	28480	0160-4554
A1C43	0180-0291	3		CAPACITOR-FXD 1UF+-10% 35VDC TA	56289	150D105X9035A2
A1C44	0180-0291	3		CAPACITOR-FXD 1UF+-10% 35VDC TA	56289	150D105X9035A2
A1C45	0160-3879	7		CAPACITOR-FXD .01UF +-20% 100VDC CER	28480	0160-3879
A1C46	0160-4822	2		CAPACITOR-FXD 1000PF +-5% 100VDC CER	28480	0160-4822
A1C47	0160-4554	7		CAPACITOR-FXD .01UF +-20% 50VDC CER	28480	0160-4554
A1C48	0160-4822	2		CAPACITOR-FXD 1000PF +-5% 100VDC CER	28480	0160-4822
A1C49	0160-4554	7		CAPACITOR-FXD .01UF +-20% 50VDC CER	28480	0160-4554
A1C50	0160-4810	8	1	CAPACITOR-FXD 330PF +-5% 100VDC CER	28480	0160-4810
A1C51	0160-4554	7		CAPACITOR-FXD .01UF +-20% 50VDC CER	28480	0160-4554
A1C52	0160-4554	7		CAPACITOR-FXD .01UF +-20% 50VDC CER	28480	0160-4554
A1C53	0160-0127	2		CAPACITOR-FXD 1UF +-20% 25VDC CER	28480	0160-0127
A1C54	0180-0418	6	1	CAPACITOR-FXD 1UF+-20% 35VDC TA	28480	0180-0418
A1C55	0160-4808	4	3	CAPACITOR-FXD 470PF +-5% 100VDC CER	28480	0160-4808
A1C56	0160-4808	4		CAPACITOR-FXD 470PF +-5% 100VDC CER	28480	0160-4808
A1C57	0160-4808	4		CAPACITOR-FXD 470PF +-5% 100VDC CER	28480	0160-4808
A1C58	0160-4554	7		CAPACITOR-FXD .01UF +-20% 50VDC CER	28480	0160-4554
A1C59	0160-3879	7		CAPACITOR-FXD .01UF +-20% 100VDC CER	28480	0160-3879
A1C60	0160-3878	6	1	CAPACITOR-FXD 1000PF +-20% 100VDC CER	28480	0160-3878

See introduction to this section for ordering information
*Indicates factory selected value

HP 5384A and HP 5385A
Replaceable Parts

Table 6-4. HP 5384A With Oven Oscillator Replaceable Parts (Continued)

Reference Designation	HP Part Number	C D	Qty	Description	Mfr Code	Mfr Part Number
A1C61- A1C66 A1C67 A1C68 A1C69	0160-3879 0160-4554 0160-0127	7 7 2	2	NOT ASSIGNED CAPACITOR-FXD .01UF +-20% 100VDC CER CAPACITOR-FXD .01UF +-20% 50VDC CER CAPACITOR-FXD 1UF +-20% 25VDC CER	28480 28480 28480	0160-3879 0160-4554 0160-0127
A1C70 A1C71 A1C72 A1C73 A1C74	0160-4819 0160-4805 0180-0562	7 1 1	1	CAPACITOR-FXD 2200PF +-5% 100VDC CER CAPACITOR-FXD 47PF +-5% 100VDC CER 0+-30 CAPACITOR-FXD 33UF+-20% 10VDC TA NOT ASSIGNED NOT ASSIGNED	28480 28480 56289	0160-4819 0160-4805 196D336X0010KA1
A1C75	0180-0562	1		CAPACITOR-FXD 33UF+-20% 10VDC TA	56289	196D336X0010KA1
A1CR1 A1CR2 A1CR3 A1CR4 A1CR5	1901-0050 1901-0376 1901-0376 1901-0535 1901-0639	3 6 6 9 4	13	DIODE-SWITCHING 80V 200MA 2NS DO-35 DIODE-GEN PRP 35V 50MA DO-35 DIODE-GEN PRP 35V 50MA DO-35 DIODE-SM SIG SCHOTTKY DIODE-PIN	28480 28480 28480 28480 28480	1901-0050 1901-0376 1901-0376 1901-0535 5082-3080
A1CR6 A1CR7 A1CR8 A1CR9 A1CR10	1901-0050 1901-0050 1906-0096 1884-0221 1902-3234	3 3 7 2 3	1	DIODE-SWITCHING 80V 200MA 2NS DO-35 DIODE-SWITCHING 80V 200MA 2NS DO-35 DIODE-FW BRDG 200V 2A THYRISTOR-SCR VRRM-300 DIODE-ZNR 19.6V 5% DO-35 PD=.4W	28480 28480 04713 04713 28480	1901-0050 1901-0050 MDA202 MCR106-5 1902-3234
A1CR11 A1CR12 A1CR13 A1CR14 A1CR15	1901-0050 1901-0782 1902-3110 1901-0782 1901-0050	3 8 4 8 3	2	DIODE-SWITCHING 80V 200MA 2NS DO-35 DIODE-SCHOTTKY 1N5821 30V 3A DIODE-ZNR 5.9V 2% DO-35 PD=.4W TC=+.017% DIODE-SCHOTTKY 1N5821 30V 3A DIODE-SWITCHING 80V 200MA 2NS DO-35	28480 04713 28480 04713 28480	1901-0050 1N5821 1902-3110 1N5821 1901-0050
A1CR16 A1CR17 A1CR18 A1CR19 A1CR20	1901-0050 1901-0050 1901-0050 1901-0050 1901-0050	3 3 3 3 3		DIODE-SWITCHING 80V 200MA 2NS DO-35 DIODE-SWITCHING 80V 200MA 2NS DO-35 DIODE-SWITCHING 80V 200MA 2NS DO-35 DIODE-SWITCHING 80V 200MA 2NS DO-35 DIODE-SWITCHING 80V 200MA 2NS DO-35	28480 28480 28480 28480 28480	1901-0050 1901-0050 1901-0050 1901-0050 1901-0050
A1CR21 A1CR22 A1CR23	1901-0050 1901-0050 1901-0050	3 3 3		DIODE-SWITCHING 80V 200MA 2NS DO-35 DIODE-SWITCHING 80V 200MA 2NS DO-35 DIODE-SWITCHING 80V 200MA 2NS DO-35	28480 28480 28480	1901-0050 1901-0050 1901-0050
A1E1	9170-0029	3	1	CORE-SHIELDING BEAD	28480	9170-0029
A1F1 A1F1 A1F2	2110-0201 2110-0565 2110-0002	0 9 9	1	FUSE .25A 250V TD 1.25X.25 UL FUSEHOLDER CAP 12A MAX FOR UL FUSE 2A 250V NTD 1.25X.25 UL	28480 28480 75915	2110-0201 2110-0565 312002
A1J1 A1J2 A1J3 A1J4 A1J5	1250-1782 1250-1782 1251-4743 1251-8261 1250-1842	9 9 0 5 2	2	CONNECTOR-RF BNC FEM PCH-PNL 50-OHM CONNECTOR-RF BNC FEM PCH-PNL 50-OHM CONNECTOR-AC PWR HP-9 MALE REC-FLG THRMP JACK POWER PCB MT BNC RTANG PC MNT	28480 28480 28480 28480 28480	1250-1782 1250-1782 1251-4743 1251-8261 1250-1842
A1J6 A1J7 A1J8 A1J9	1251-8304 1251-7684 1251-8139	7 4 6	1	CONN-POST TYPE .100-PIN-SPCG 8-CONT NOT ASSIGNED CABLE ASSY 14 POST CONN-POST TYPE .100-PIN-SPCG 14-CONT	28480 28480 28480	1251-8304 1251-7684 1251-8139
A1K1	0490-1317	3	1	RELAY-REED 1C 250MA 200VDC 5VDC-COIL 3VA	28480	0490-1317
A1L1 A1L2 A1L3 A1L4 A1L5	9140-0718 9100-1788 9100-1788 9100-2562	4 6 6 6	1	INDUCTOR-FIXED NORM IND: 230UH à 1.5ADC CORE-FERRITE CHOKE-WIDEBAND; IMP:>680 CORE-FERRITE CHOKE-WIDEBAND; IMP:>680 INDUCTOR RF-CH-MLD 100UH 10% NOT ASSIGNED	28480 28480 28480 28480	9140-0718 9100-1788 9100-1788 9100-2562
A1L6 A1L7	9100-1788 9100-1788	6 6		CORE-FERRITE CHOKE-WIDEBAND; IMP:>680 CORE-FERRITE CHOKE-WIDEBAND; IMP:>680	28480 28480	9100-1788 9100-1788
A1Q1 A1Q2 A1Q3 A1Q4 A1Q5	1854-0215 1855-0327 1853-0354 1855-0414 1854-0215	1 8 7 4 1	3	TRANSISTOR NPN SI PD=350MW FT=300MHZ TRANSISTOR J-FET 2N4416 N-CHAN D-MODE TRANSISTOR PNP SI T0-92 PD=350MW TRANSISTOR J-FET 2N4393 N-CHAN D-MODE TRANSISTOR NPN SI PD=350MW FT=300MHZ	04713 01295 28480 04713 04713	2N3904 2N4416 1853-0354 2N4393 2N3904

See introduction to this section for ordering information
*Indicates factory selected value

Table 6-4. HP 5384A With Oven Oscillator Replaceable Parts (Continued)

Reference Designation	HP Part Number	C D	Qty	Description	Mfr Code	Mfr Part Number
A1Q6	1854-0574	5	1	TRANSISTOR NPN SI PD=500MW FT=125MHZ	28480	1854-0574
A1Q7	1854-0215	1		TRANSISTOR NPN SI PD=350MW FT=300MHZ	04713	2N3904
A1Q8	1853-0015	7	2	TRANSISTOR PNP SI PD=200MW FT=500MHZ	28480	1853-0015
A1Q9	1853-0015	7		TRANSISTOR PNP SI PD=200MW FT=500MHZ	28480	1853-0015
A1Q10	1853-0363	8	1	TRANSISTOR PNP SI PD=50W FT=20MHZ	03508	X45H281
A1Q11	1854-0013	7	1	TRANSISTOR NPN 2N2218A SI T0-5 PD=800MW	04713	2N2218A
A1Q12	1854-0477	7	1	TRANSISTOR NPN 2N2222A SI T0-18 PD=500MW	04713	2N2222A
A1R1	0698-8827	4	2	RESISTOR 1M 1% .125W F TC=0+-100	28480	0698-8827
A1R2	0698-8827	4		RESISTOR 1M 1% .125W F TC=0+-100	28480	0698-8827
A1R3	0757-0706	8	3	RESISTOR 51.1 1% .25W F TC=0+-100	24546	C5-1/4-T0-51R1-F
A1R4	0699-0071	6	2	RESISTOR 4.64M 1% .125W F TC=0+-100	28480	0699-0071
A1R5	0698-7276	5	1	RESISTOR 46.4K 1% .05W F TC=0+-100	24546	C3-1/8-T0-4642-F
A1R6	0757-0346	2	2	RESISTOR 10 1% .125W F TC=0+-100	24546	C4-1/8-T0-10R0-F
A1R7	0757-0421	4	3	RESISTOR 825 1% .125W F TC=0+-100	24546	C4-1/8-T0-825R-F
A1R8	0698-3445	2	2	RESISTOR 348 1% .125W F TC=0+-100	24546	C4-1/8-T0-348R-F
A1R9	0698-7236	7	3	RESISTOR 1K 1% .05W F TC=0+-100	24546	C3-1/8-T0-1001-F
A1R10	0698-7233	4	1	RESISTOR 750 1% .05W F TC=0+-100	24546	C3-1/8-T0-750R-F
A1R11	0698-7283	4	1	RESISTOR 90.9K 1% .05W F TC=0+-100	24546	C3-1/8-T0-9092-F
A1R12	0698-8812	7	1	RESISTOR 1 1% .125W F TC=0+-100	28480	0698-8812
A1R13	0698-3136	8	1	RESISTOR 17.8K 1% .125W F TC=0+-100	24546	C4-1/8-T0-1782-F
A1R14	0698-7244	7	2	RESISTOR 2.15K 1% .05W F TC=0+-100	24546	C3-1/8-T0-2151-F
A1R15	0698-3447	4	2	RESISTOR 422 1% .125W F TC=0+-100	24546	C4-1/8-T0-422R-F
A1R16	0698-3447	4		RESISTOR 422 1% .125W F TC=0+-100	24546	C4-1/8-T0-422R-F
A1R17	1810-0541	4	1	NETWORK-RES 6-SIP MULTI-VALUE	28480	1810-0541
A1R18	1810-0219	3	1	NETWORK-RES 8-SIP220.0 OHM X 4	01121	208B221
A1R19	0698-7220	9	3	RESISTOR 215 1% .05W F TC=0+-100	24546	C3-1/8-T0-215R-F
A1R20	0698-7220	9		RESISTOR 215 1% .05W F TC=0+-100	24546	C3-1/8-T0-215R-F
A1R21	0698-7249	2	2	RESISTOR 3.48K 1% .05W F TC=0+-100	24546	C3-1/8-T0-3481-F
A1R22	0757-0283	6	3	RESISTOR 2K 1% .125W F TC=0+-100	24546	C4-1/8-T0-2001-F
A1R23	0698-7267	4	1	RESISTOR 19.6K 1% .05W F TC=0+-100	24546	C3-1/8-T0-1962-F
A1R24	0698-7210	7	1	RESISTOR 82.5 1% .05W F TC=0+-100	24546	C3-1/8-T0-82R5-F
A1R25	0757-0706	8		RESISTOR 51.1 1% .25W F TC=0+-100	24546	C5-1/4-T0-51R1-F
A1R26	0757-0706	8		RESISTOR 51.1 1% .25W F TC=0+-100	24546	C5-1/4-T0-51R1-F
A1R27	0698-7244	7		RESISTOR 2.15K 1% .05W F TC=0+-100	24546	C3-1/8-T0-2151-F
A1R28	0698-7249	2		RESISTOR 3.48K 1% .05W F TC=0+-100	24546	C3-1/8-T0-3481-F
A1R29	0698-7236	7		RESISTOR 1K 1% .05W F TC=0+-100	24546	C3-1/8-T0-1001-F
A1R30	0698-3437	2	2	RESISTOR 133 1% .125W F TC=0+-100	24546	C4-1/8-T0-133R-F
A1R31	0698-3437	2		RESISTOR 133 1% .125W F TC=0+-100	24546	C4-1/8-T0-133R-F
A1R32	2100-0558	9	2	RESISTOR-TRMR 20K 10% C TOP-ADJ 1-TRN	28480	2100-0558
A1R33	0698-3442	9	1	RESISTOR 237 1% .125W F TC=0+-100	24546	C4-1/8-T0-237R-F
A1R34	0698-7265	2	1	RESISTOR 16.2K 1% .05W F TC=0+-100	24546	C3-1/8-T0-1622-F
A1R35	0698-7236	7		RESISTOR 1K 1% .05W F TC=0+-100	24546	C3-1/8-T0-1001-F
A1R36	0698-7229	8	6	RESISTOR 511 1% .05W F TC=0+-100	24546	C3-1/8-T0-511R-F
A1R37	0698-7205	0	3	RESISTOR 51.1 1% .05W F TC=0+-100	24546	C3-1/8-T0-51R1-F
A1R38	0698-7205	0		RESISTOR 51.1 1% .05W F TC=0+-100	24546	C3-1/8-T0-51R1-F
A1R39	0698-7229	8		RESISTOR 511 1% .05W F TC=0+-100	24546	C3-1/8-T0-511R-F
A1R40	0698-7220	9		RESISTOR 215 1% .05W F TC=0+-100	24546	C3-1/8-T0-215R-F
A1R41	0698-3156	2	2	RESISTOR 14.7K 1% .125W F TC=0+-100	24546	C4-1/8-T0-1472-F
A1R42	0698-7229	8		RESISTOR 511 1% .05W F TC=0+-100	24546	C3-1/8-T0-511R-F
A1R43	2100-0558	9		RESISTOR-TRMR 20K 10% C TOP-ADJ 1-TRN	28480	2100-0558
A1R44	0698-7284	5	1	RESISTOR 100K 1% .05W F TC=0+-100	24546	C3-1/8-T0-1003-F
A1R45*	0698-7206	1	1	RESISTOR 56.2 1% .05W F TC=0+-100	24546	C3-1/8-T0-56R2-F
A1R46	0698-7205	0		RESISTOR 51.1 1% .05W F TC=0+-100	24546	C3-1/8-T0-51R1-F
A1R47	0698-7229	8		RESISTOR 511 1% .05W F TC=0+-100	24546	C3-1/8-T0-511R-F
A1R48	0698-7243	6	1	RESISTOR 1.96K 1% .05W F TC=0+-100	24546	C3-1/8-T0-1961-F
A1R49	1810-0488	8	1	NETWORK-RES 8-SIP4.7K OHM X 4	28480	1810-0488
A1R50	0812-0021	8	1	RESISTOR .47 5% 3W PW TC=0+-90	91637	CU2B1-3-T2-47/100-J
A1R51	0698-7229	8		RESISTOR 511 1% .05W F TC=0+-100	24546	C3-1/8-T0-511R-F
A1R52	0757-0394	0	3	RESISTOR 51.1 1% .125W F TC=0+-100	24546	C4-1/8-T0-51R1-F
A1R53	0698-3132	4	3	RESISTOR 261 1% .125W F TC=0+-100	24546	C4-1/8-T0-2610-F
A1R54	0757-1093	8	2	RESISTOR 3K 1% .125W F TC=0+-100	24546	C4-1/8-T0-3001-F
A1R55	0757-0465	6	2	RESISTOR 100K 1% .125W F TC=0+-100	24546	C4-1/8-T0-1003-F
A1R56	0757-0407	6	1	RESISTOR 200 1% .125W F TC=0+-100	24546	C4-1/8-T0-201-F
A1R57	0757-0289	2	1	RESISTOR 13.3K 1% .125W F TC=0+-100	19701	MF4C1/8-T0-1332-F
A1R58	0757-0399	5	1	RESISTOR 82.5 1% .125W F TC=0+-100	24546	C4-1/8-T0-82R5-F
A1R59	0757-0416	7	3	RESISTOR 511 1% .125W F TC=0+-100	24546	C4-1/8-T0-511R-F
A1R60	0757-0346	2		RESISTOR 10 1% .125W F TC=0+-100	24546	C4-1/8-T0-10R0-F

See introduction to this section for ordering information
*Indicates factory selected value

HP 5384A and HP 5385A
Replaceable Parts

Table 6-4. HP 5384A With Oven Oscillator Replaceable Parts (Continued)

Reference Designation	HP Part Number	C	D	Qty	Description	Mfr Code	Mfr Part Number
A1R61	0698-3398	4		1	RESISTOR 46.4 1% .5W F TC=0+-100	28480	0698-3398
A1R62	0757-0200	7		2	RESISTOR 5.62K 1% .125W F TC=0+-100	24546	C4-1/8-T0-5621-F
A1R63	0757-0200	7			RESISTOR 5.62K 1% .125W F TC=0+-100	24546	C4-1/8-T0-5621-F
A1R64	0699-0071	6			RESISTOR 4.64M 1% .125W F TC=0+-100	28480	0699-0071
A1R65	1810-0370	7		1	NETWORK-RES 8-SIP220.0 OHM X 7	01121	208A221
A1R66	0757-0394	0			RESISTOR 51.1 1% .125W F TC=0+-100	24546	C4-1/8-T0-51R1-F
A1R67	0757-0394	0			RESISTOR 51.1 1% .125W F TC=0+-100	24546	C4-1/8-T0-51R1-F
A1R68	0698-3441	8		2	RESISTOR 215 1% .125W F TC=0+-100	24546	C4-1/8-T0-215R-F
A1R69	0698-3441	8			RESISTOR 215 1% .125W F TC=0+-100	24546	C4-1/8-T0-215R-F
A1R70	0698-7212	9		2	RESISTOR 100 1% .05W F TC=0+-100	24546	C3-1/8-T0-100R-F
A1R71	0698-7212	9			RESISTOR 100 1% .05W F TC=0+-100	24546	C3-1/8-T0-100R-F
A1R72	0698-3156	2			RESISTOR 14.7K 1% .125W F TC=0+-100	24546	C4-1/8-T0-1472-F
A1R73	0698-7197	9		1	RESISTOR 23.7 1% .05W F TC=0+-100	24546	C3-1/8-T0-23R7-F
A1R74	0698-7219	6		1	RESISTOR 196 1% .05W F TC=0+-100	24546	C3-1/8-T0-196R-F
A1R75	0757-0420	3		2	RESISTOR 750 1% .125W F TC=0+-100	24546	C4-1/8-T0-751-F
A1R76	0757-0419	0		1	RESISTOR 881 1% .125W F TC=0+-100	24546	C4-1/8-T0-681R-F
A1R77	2100-0554	5		1	RESISTOR-TRMR 500 10% C TOP-ADJ 1-TRN	28480	2100-0554
A1R78	0757-0465	6			RESISTOR 100K 1% .125W F TC=0+-100	24546	C4-1/8-T0-100K-F
A1R79	0757-0420	3			RESISTOR 750 1% .125W F TC=0+-100	24546	C4-1/8-T0-751-F
A1R80	0698-0082	7		5	RESISTOR 464 1% .125W F TC=0+-100	24546	C4-1/8-T0-4640-F
A1R81	0698-0082	7			RESISTOR 464 1% .125W F TC=0+-100	24546	C4-1/8-T0-4640-F
A1R82	0757-0283	6			RESISTOR 2K 1% .125W F TC=0+-100	24546	C4-1/8-T0-2001-F
A1R83	0757-1093	8			RESISTOR 3K 1% .125W F TC=0+-100	24546	C4-1/8-T0-3001-F
A1R84	0698-0082	7			RESISTOR 464 1% .125W F TC=0+-100	24546	C4-1/8-T0-4640-F
A1R85	0698-0082	7			RESISTOR 464 1% .125W F TC=0+-100	24546	C4-1/8-T0-4640-F
A1R86	0698-3445	2			RESISTOR 348 1% .125W F TC=0+-100	24546	C4-1/8-T0-348R-F
A1R87	0757-0421	4			RESISTOR 825 1% .125W F TC=0+-100	24546	C4-1/8-T0-825R-F
A1R88	0757-0421	4			RESISTOR 825 1% .125W F TC=0+-100	24546	C4-1/8-T0-825R-F
A1R89	0698-3460	1		1	RESISTOR 422K 1% .125W F TC=0+-100	28480	0698-3460
A1R90	0757-0416	7			RESISTOR 511 1% .125W F TC=0+-100	24546	C4-1/8-T0-511R-F
A1R91	0698-3132	4			RESISTOR 261 1% .125W F TC=0+-100	24546	C4-1/8-T0-2610-F
A1R92	0698-3132	4			RESISTOR 261 1% .125W F TC=0+-100	24546	C4-1/8-T0-2610-F
A1R93	0757-0280	3		2	RESISTOR 1K 1% .125W F TC=0+-100	24546	C4-1/8-T0-1001-F
A1R94	0698-7229	8			RESISTOR 511 1% .05W F TC=0+-100	24546	C3-1/8-T0-511R-F
A1R95	0757-0401	0		2	RESISTOR 100 1% .125W F TC=0+-100	24546	C4-1/8-T0-101-F
A1R96- A1R101					NOT ASSIGNED		
A1R102	0757-0280	3			RESISTOR 1K 1% .125W F TC=0+-100	24546	C4-1/8-T0-1001-F
A1R103	0757-0416	7			RESISTOR 511 1% .125W F TC=0+-100	24546	C4-1/8-T0-511R-F
A1R104	0698-3152	8		1	RESISTOR 3.48K 1% .125W F TC=0+-100	24546	C4-1/8-T0-3481-F
A1R105	0757-0283	6			RESISTOR 2K 1% .125W F TC=0+-100	24546	C4-1/8-T0-2001-F
A1R106	0837-0220	1		1	THERMISTOR ROD 10K-OHM TC=-3.83%/C-DEG	28480	0837-0220
A1R107	1810-0368	3		1	NETWORK-RES 6-SIP10.0K OHM X 5	01121	206A103
A1R108	0698-0082	7			RESISTOR 464 1% .125W F TC=0+-100	24546	C4-1/8-T0-4640-F
A1R109	0757-0401	0			RESISTOR 100 1% .125W F TC=0+-100	24546	C4-1/8-T0-101-F
A1S2	3101-2644	1		1	SWITCH-PB DPDT ALTNG .5A 100VAC	28480	3101-2644
A1S3	3101-2453	0		1	SWITCH-TGL SUBMIN DPDT .02A 20VAC/DC PC	28480	3101-2453
A1TP1	1251-0600	0		10	CONNECTOR-SGL CONT PIN 1.14-MM-BSC-SZ SQ	28480	1251-0600
A1TP2	1251-0600	0			CONNECTOR-SGL CONT PIN 1.14-MM-BSC-SZ SQ	28480	1251-0600
A1TP3	1251-0600	0			CONNECTOR-SGL CONT PIN 1.14-MM-BSC-SZ SQ	28480	1251-0600
A1TP4	1251-0600	0			CONNECTOR-SGL CONT PIN 1.14-MM-BSC-SZ SQ	28480	1251-0600
A1TP5	1251-0600	0			CONNECTOR-SGL CONT PIN 1.14-MM-BSC-SZ SQ	28480	1251-0600
A1TP6	1251-0600	0			CONNECTOR-SGL CONT PIN 1.14-MM-BSC-SZ SQ	28480	1251-0600
A1TP7	1251-0600	0			CONNECTOR-SGL CONT PIN 1.14-MM-BSC-SZ SQ	28480	1251-0600
A1TP8	1251-0600	0			CONNECTOR-SGL CONT PIN 1.14-MM-BSC-SZ SQ	28480	1251-0600
A1TP9	1251-0600	0			CONNECTOR-SGL CONT PIN 1.14-MM-BSC-SZ SQ	28480	1251-0600
A1TP10	1251-0600	0			CONNECTOR-SGL CONT PIN 1.14-MM-BSC-SZ SQ	28480	1251-0600
A1U1	1820-2312	2		1	IC MISC	28480	1820-2312
A1U2	1820-3572	8		1	IC-MCU W/ROM/RAM; 4MHZ	28480	1820-3572
A1U3	1820-3075	6		2	IC RCVR ECL/10KH LINE RCVR TPL	28480	1820-3075
A1U4	1820-3075	6			IC RCVR ECL/10KH LINE RCVR TPL	28480	1820-3075
A1U5	1820-3076	7		1	IC FF ECL/10KH D-M/S COM CLOCK DUAL	28480	1820-3076
A1U6	1858-0040	8		1	TRANSISTOR ARRAY 16-PIN PLSTC DIP	3L585	CA3127E
A1U7	1826-0904	6		1	IC-LM330T-5.0	28480	1826-0904
A1U8					NOT ASSIGNED		
A1U9	1826-0428	9		1	IC 3524 MODULATOR 16-DIP-C	01295	SG3524J
A1U10	1826-0293	6		1	IC AUDIO AMPL 8-DIP-P PKG	04713	MC1305P

See introduction to this section for ordering information
*Indicates factory selected value

Table 6-4. HP 5384A With Oven Oscillator Replaceable Parts (Continued)

Reference Designation	HP Part Number	C D	Qty	Description	Mfr Code	Mfr Part Number
A1U11	1858-0054	4	1	TRANSISTOR ARRAY 16-PIN PLSTC DIP	28480	1858-0054
A1U12	1826-0065	0	1	IC COMPARATOR PRCN 8-DIP-P PKG	S0545	UPC311C
A1U13	1820-1425	6	1	IC SCHMITT-TRIG TTL LS NAND QUAD 2-INP	01295	SN74LS132N
A1U14	1820-2096	9	1	IC CNTR TTL LS BIN DUAL 4-BIT	01295	SN74LS393N
A1U15	1820-1975	1	1	IC SHF-RGTR TTL LS NEG-EDGE-TRIG PRL-IN	01295	SN74LS165N
A1U16	1826-050	9	1	IC MULTIPLXR 2-CHAN-ANLG TRIPLE 16-DIP-P	04713	MC140538CP
A1W1	8120-1378	1	1	CABLE ASSY 18AWG 3-CNDCT JGK-JKT	28480	8120-1378
A1W2	8120-4167	2	1	CBLY 14 PIN FT 26G	28480	8120-4167
A1XF1	2110-0269	0	1	FUSEHOLDER-CLIP TYPE.25D-FUSE	28480	2110-0269
A1XF2	2110-0642	3	1	FUSEHOLDER-EXTR POST 6.3A 250V BAY CAP	28480	2110-0642
A1XU1	1200-0654	7	2	SOCKET-IC 40-CONT DIP DIP-SLDR	28480	1200-0654
A1XU2	1200-0654	7	2	SOCKET-IC 40-CONT DIP DIP-SLDR	28480	1200-0654
A1XW1	1200-0473	8	1	SOCKET-IC 16-CONT DIP DIP-SLDR	28480	1200-0473
A1Y1A	0960-0636	4	1	OVEN-OSCILLATOR MODULE FREQ: 10 MHZ	28480	0960-0636
	0515-0105	9	4	SCREW-MACH M3 X 0.5 12MM-LG PAN-HD	28480	0515-0105
	0535-0004	9	2	NUT-HEX DBL-CHAM M3 X 0.5 2.4MM-THK	00000	ORDER BY DESCRIPTION
	2190-0597	5	2	WASHER-LK EXT T 3.0 MM 3.2-MM-ID 6-MM-OD	28480	2190-0597

See introduction to this section for ordering information
*Indicates factory selected value

HP 5384A and HP 5385A
 Replaceable Parts

Table 6-5. Front Panel Display Assembly Replaceable Parts

Reference Designation	HP Part Number	C D	Qty	Description	Mfr Code	Mfr Part Number
A2	05384-60102	8	1	DISPLAY ASSEMBLY	28480	05384-60102
	05384-60104	0	1	KEYBOARD ASSEMBLY	28480	05384-60104
				LIQUID CRYSTAL DISPLAY ASSEMBLY		
MP12	5040-5448	1	1	LCD WINDOW	28480	5040-5448

See introduction to this section for ordering information
 *Indicates factory selected value

Table 6-6. Battery Pack Replaceable Parts

Reference Designation	HP Part Number	C D	Qty	Description	Mfr Code	Mfr Part Number
A3	05384-60003	8	1	ASSEMBLY-BATTERY PACK (SERIES 2244)	28480	05384-60003
A3C1	0160-4554	7	2	CAPACITOR-FXD .01UF +-20% 50VDC CER	28480	0160-4554
A3C2	0180-0291	3	2	CAPACITOR-FXD 1UF+-10% 35VDC TA	56289	150D105X9035A2
A3C3	0160-4554	7		CAPACITOR-FXD .01UF +-20% 50VDC CER	28480	0160-4554
A3C4	0180-0291	3		CAPACITOR-FXD 1UF+-10% 35VDC TA	56289	150D105X9035A2
A3C5	0180-0116	1	1	CAPACITOR-FXD 6.8UF+-10% 35VDC TA	56289	150D685X9035B2
A3CR1				NOT ASSIGNED		
A3CR2	1901-0050	3	6	DIODE-SWITCHING 80V 200MA 2NS DO-35	28480	1901-0050
A3CR3	1901-0050	3		DIODE-SWITCHING 80V 200MA 2NS DO-35	28480	1901-0050
A3CR4	1901-0050	3		DIODE-SWITCHING 80V 200MA 2NS DO-35	28480	1901-0050
A3CR5	1901-0050	3		DIODE-SWITCHING 80V 200MA 2NS DO-35	28480	1901-0050
A3CR6	1901-0050	3		DIODE-SWITCHING 80V 200MA 2NS DO-35	28480	1901-0050
A3CR7	1901-0050	3		DIODE-SWITCHING 80V 200MA 2NS DO-35	28480	1901-0050
A3CR8	1901-1080	1	1	DIODE-SCHOTTKY 1N5817 20V 1A	28480	1901-1080
A3CR9	1901-0676	9	1	DIODE-SCHOTTKY 20V 5A	28480	1901-0676
A3F1	2110-0454	5	1	FUSE 7A 125V .281X.093	28480	2110-0454
A3J1	1251-8139	6	1	CONN-POST TYPE .100-PIN-SPCG 14-CONT	28480	1251-8139
A3Q1	1858-0054	4	1	TRANSISTOR ARRAY 16-PIN PLSTC DIP	28480	1858-0054
A3Q2	1853-0363	8	1	TRANSISTOR PNP SI PD=50W FT=20MHZ	03508	X45H281
A3R1	0811-3333	9	1	RESISTOR .05 3% 2W PWJ TC=0+-150	28480	0811-3333
A3R2	0757-0424	7	2	RESISTOR 1.1K 1% .125W F TC=0+-100	24546	C4-1/8-T0-1101-F
A3R3	0757-0422	5	1	RESISTOR 909 1% .125W F TC=0+-100	24546	C4-1/8-T0-909R-F
A3R4				NOT ASSIGNED		
A3R5	0757-0442	9	3	RESISTOR 10K 1% .125W F TC=0+-100	24546	C4-1/8-T0-1002-F
A3R6	0757-0465	6	5	RESISTOR 100K 1% .125W F TC=0+-100	24546	C4-1/8-T0-1003-F
A3R7	0698-3161	9	1	RESISTOR 38.3K 1% .125W F TC=0+-100	24546	C4-1/8-T0-3832-F
A3R8	0757-0465	6		RESISTOR 100K 1% .125W F TC=0+-100	24546	C4-1/8-T0-1003-F
A3R9	0757-0442	9		RESISTOR 10K 1% .125W F TC=0+-100	24546	C4-1/8-T0-1002-F
A3R10	0757-0397	3	1	RESISTOR 68.1 1% .125W F TC=0+-100	24546	C4-1/8-T0-68R1-F
A3R11	0757-0465	6		RESISTOR 100K 1% .125W F TC=0+-100	24546	C4-1/8-T0-1003-F
A3R12	0757-0442	9		RESISTOR 10K 1% .125W F TC=0+-100	24546	C4-1/8-T0-1002-F
A3R13	0757-0283	6	1	RESISTOR 2K 1% .125W F TC=0+-100	24546	C4-1/8-T0-2001-F
A3R14	0757-0407	6	1	RESISTOR 200 1% .125W F TC=0+-100	24546	C4-1/8-T0-201-F
A3R15	0698-3152	8	1	RESISTOR 3.48K 1% .125W F TC=0+-100	24546	C4-1/8-T0-3481-F
A3R16	0757-0472	5	1	RESISTOR 200K 1% .125W F TC=0+-100	24546	C4-1/8-T0-2003-F
A3R17	0757-0424	7		RESISTOR 1.1K 1% .125W F TC=0+-100	24546	C4-1/8-T0-1101-F
A3R18	0698-3266	5	1	RESISTOR 237K 1% .125W F TC=0+-100	24546	C4-1/8-T0-2373-F
A3R19	0757-0465	6		RESISTOR 100K 1% .125W F TC=0+-100	24546	C4-1/8-T0-1003-F
A3R20	0757-0199	3	1	RESISTOR 21.5K 1% .125W F TC=0+-100	24546	C4-1/8-T0-2152-F
A3R21	0698-4008	5	1	RESISTOR 40K 1% .125W F TC=0+-100	24546	C4-1/8-T0-4002-F
A3R22	0757-0463	4	1	RESISTOR 82.5K 1% .125W F TC=0+-100	24546	C4-1/8-T0-8252-F
A3R23	0757-0465	6		RESISTOR 100K 1% .125W F TC=0+-100	24546	C4-1/8-T0-1003-F
A3R24	0757-0427	0	1	RESISTOR 1.5K 1% .125W F TC=0+-100	24546	C4-1/8-T0-1501-F
A3R25	2100-3211	7	2	RESISTOR-TRMR 1K 10% C TOP-ADJ 1-TRN	28480	2100-3211
A3R26	2100-3211	7		RESISTOR-TRMR 1K 10% C TOP-ADJ 1-TRN	28480	2100-3211
A3U1	1826-0544	0	1	IC V RGLTR-V-REF-FXD 2.5V 8-DIP-C PKG	28480	1826-0544
A3U2	1826-0161	7	1	IC OP AMP GP QUAD 14-DIP-P PKG	04713	MLM324P
A3W1	05315-60102	5	1	CABLE ASSY-POS LEAD	28480	05315-60102
A3W2	05315-60103	6	1	CABLE ASSY-NEG LEAD	28480	05315-60103
W2	8120-4167	2	1	CBLY 14 PIN FT 26G	28480	8120-4167

See introduction to this section for ordering information
*Indicates factory selected value

HP 5384A and HP 5385A
Replaceable Parts

Table 6-7. HP-IL Replaceable Parts

Reference Designation	HP Part Number	C D	Qty	Description	Mfr Code	Mfr Part Number
A4	05006-60004	2	1	BOARD ASSEMBLY HP-IL (SERIES 2243)	28480	05006-60004
A4C1	0160-4801	7	1	CAPACITOR-FXD 100PF +-5% 100VDC CER	28480	0160-4801
A4C2	0160-4812	0	2	CAPACITOR-FXD 220PF +-5% 100VDC CER	28480	0160-4812
A4C3	0160-4812	0		CAPACITOR-FXD 220PF +-5% 100VDC CER	28480	0160-4812
A4C4	0180-0210	6	1	CAPACITOR-FXD 3.3UF+-20% 15VDC TA	56289	150D335X0015A2
A4C5	0160-4557	0	1	CAPACITOR-FXD .1UF +-20% 50VDC CER	16299	CAC04X7R104M050A
A4CR1	1902-0970	8	4	DIODE-ZNR 33V 5% DO-35 PD=.4W TC=+.097%	28480	1902-0970
A4CR2	1902-0970	8		DIODE-ZNR 33V 5% DO-35 PD=.4W TC=+.097%	28480	1902-0970
A4CR3	1902-0970	8		DIODE-ZNR 33V 5% DO-35 PD=.4W TC=+.097%	28480	1902-0970
A4CR4	1902-0970	8		DIODE-ZNR 33V 5% DO-35 PD=.4W TC=+.097%	28480	1902-0970
A4CR5	1901-0050	3	1	DIODE-SWITCHING 80V 200MA 2NS DO-35	28480	1901-0050
A4J1	05006-60104	3	1	CONN AY-HPIL	28480	05006-60104
A4J2	1251-8426	4	1	HEADER ASSY, 8 PIN	28480	1251-8426
A4L1	9100-1631	8	1	INDUCTOR RF-CH-MLD 56UH 5% .166DX.385LG	28480	9100-1631
A4L2	9100-1637	4	1	INDUCTOR RF-CH-MLD 120UH 5% .166DX.385LG	28480	9100-1637
A4R1	0757-0446	3	2	RESISTOR 15K 1% .125W F TC=0+-100	24546	C4-1/8-T0-1502-F
A4R2	0698-3446	3	2	RESISTOR 383 1% .125W F TC=0+-100	24546	C4-1/8-T0-383R-F
A4R3	0757-0446	3		RESISTOR 15K 1% .125W F TC=0+-100	24546	C4-1/8-T0-1502-F
A4R4	0698-3446	3		RESISTOR 383 1% .125W F TC=0+-100	24546	C4-1/8-T0-383R-F
A4R5	0757-0465	6	1	RESISTOR 100K 1% .125W F TC=0+-100	24546	C4-1/8-T0-1003-F
A4R6	0757-0442	9	2	RESISTOR 10K 1% .125W F TC=0+-100	24546	C4-1/8-T0-1002-F
A4R7	0757-0442	9		RESISTOR 10K 1% .125W F TC=0+-100	24546	C4-1/8-T0-1002-F
A4S1	3101-2215	2	1	SWITCH-RKR DIP-RKR-ASSY 7-1A .05A 30VDC	28480	3101-2215
A4T1	9100-4226	3	1	TRANSFORMER	28480	9100-4226
A4TP1	1251-4707	6	1	CONNECTOR-SGL CONT PIN .031-IN-BSC-SZ	28480	1251-4707
A4U1	1LB3-0003	8	1	IC HPIL 28 PIN	28480	1LB3-0003
A4U2-1	1820-2650	1	1	NMOS 38P70 MICROCOMPUTER	28480	1820-2650
A4U2-2	05006-80002	2	1	HP1B PIGGYBACK EPROM	28480	05006-80002
A4W1	8120-3671	1	1	FLAT RIBBON ASSY 14-COND	28480	8120-3671
A4XU1	1200-0567	1	1	SOCKET-IC 28-CONT DIP DIP-SLDR	28480	1200-0567
A4XU2	1200-0654	7	1	SOCKET-IC 40-CONT DIP DIP-SLDR	28480	1200-0654

See introduction to this section for ordering information
*Indicates factory selected value

Table 6-8. HP-IB Replaceable Parts

Reference Designation	HP Part Number	C D	Qty	Description	Mfr Code	Mfr Part Number
A5	05384-60005	0	1	BOARD ASSEMBLY, HP-IB (SERIES 2244)	28480	05384-60005
ASC1	0180-0229	7	1	CAPACITOR-FXD 33UF+-10% 10VDC TA	56289	150D336X901082
ASC2	0160-4554	7	1	CAPACITOR-FXD .01UF +-20% 50VDC CER	28480	0160-4554
ASC3	0160-4557	0	2	CAPACITOR-FXD .1UF +-20% 50VDC CER	16299	CAC04X7R104M050A
ASC4	0160-4557	0	0	CAPACITOR-FXD .1UF +-20% 50VDC CER	16299	CAC04X7R104M050A
ASC5	0180-0210	6	1	CAPACITOR-FXD 3.3UF+-20% 15VDC TA	56289	150D335X0015A2
A5CR1	1901-0050	3	1	DIODE-SWITCHING 80V 200MA 2NS D0-35	28480	1901-0050
A5J1	1252-0268	8	1	CONNECTOR HP-IB 24-PIN RIBBON	28480	1252-0268
A5L1	9100-1788	6	1	CORE-FERRITE CHOKE-WIDEBAND; IMP:>680	28480	9100-1788
A5L2	9100-1637	4	1	INDUCTOR RF-CH-MLD 120UH 5% .166DX.385LG	28480	9100-1637
A5R1	0698-3155	1	2	RESISTOR 4.64K 1% .125W F TC=0+-100	24546	C4-1/8-T0-4641-F
A5R2	0698-0082	7	2	RESISTOR 464 1% .125W F TC=0+-100	24546	C4-1/8-T0-4640-F
A5R3	0698-3155	1	1	RESISTOR 4.64K 1% .125W F TC=0+-100	24546	C4-1/8-T0-4641-F
A5R4	0698-0082	7	1	RESISTOR 464 1% .125W F TC=0+-100	24546	C4-1/8-T0-4640-F
A5R5	1810-0247	7	1	NETWORK-RES 16-DIP220.0 OHM X 8	01121	3168221
A5R6	0757-0465	6	1	RESISTOR 100K 1% .125W F TC=0+-100	24546	C4-1/8-T0-1003-F
A5R7	0698-3441	8	2	RESISTOR 215 1% .125W F TC=0+-100	24546	C4-1/8-T0-215R-F
A5R8	0698-3441	8	8	RESISTOR 215 1% .125W F TC=0+-100	24546	C4-1/8-T0-215R-F
A5S1	3101-2215	2	1	SWITCH-RKR DIP-RKR-ASSY 7-1A .05A 30VDC	28480	3101-2215
A5TP1	1251-8096	4	1	HEADER ASSY 7PIN	28480	1251-8096
A5U1	1820-2461	2	2	IC MISC TTL OCTL	04713	MC3447P3
A5U2	1820-2461	2	2	IC MISC TTL OCTL	04713	MC3447P3
A5U3	1820-1198	0	1	IC GATE TTL LS NAND QUAD 2-INP	01295	SN74LS03N
A5U4	1820-1440	5	1	IC LCH TTL LS QUAD	01295	SN74LS279N
A5U5	1820-3970	0	1	NMOS 3870 MPU	28480	1820-3970
A5W1	8120-3671	1	1	FLAT RIBBON ASSY 14-COND	28480	8120-3671
A5XU5	1200-0654	7	1	SOCKET-IC 40-CONT DIP DIP-SLDR	28480	1200-0654

See introduction to this section for ordering information
*Indicates factory selected value

HP 5384A and HP 5385A
Replaceable Parts

Table 6-9. HP 5385A Replaceable Parts

Reference Designation	HP Part Number	C D	Qty	Description	Mfr Code	Mfr Part Number
A1	05385-60001	7	1	MAIN BOARD ASSEMBLY (TCXO) (SERIES 2430)	28480	05385-60001
A1C1	0160-4704	9	1	CAPACITOR-FXD .01UF +-10% 500VDC CER	28480	0160-4704
A1C2	0160-5649	3	1	CAPACITOR-FXD 100PF +-5% 500VDC CER	28480	0160-5649
A1C3	0160-4385	2	1	CAPACITOR-FXD 15PF +-5% 200VDC CER 0+-30	28480	0160-4385
A1C4	0180-2816	2	1	CAPACITOR-FXD 68UF+-20% 10VDC TA	28480	0180-2816
A1C5	0180-0562	1	4	CAPACITOR-FXD 33UF+-20% 10VDC TA	56289	196D336X0010KA1
A1C6	0160-0573	2	1	CAPACITOR-FXD 4700PF +-20% 100VDC CER	28480	0160-0573
A1C7	0180-0562	1	1	CAPACITOR-FXD 33UF+-20% 10VDC TA	56289	196D336X0010KA1
A1C8	0160-0572	1	1	CAPACITOR-FXD 2200PF +-20% 100VDC CER	28480	0160-0572
A1C9	0160-3879	7	7	CAPACITOR-FXD .01UF +-20% 100VDC CER	28480	0160-3879
A1C10	0160-3879	7	7	CAPACITOR-FXD .01UF +-20% 100VDC CER	28480	0160-3879
A1C11	0160-4492	2	2	CAPACITOR-FXD 18PF +-5% 200VDC CER 0+-30	28480	0160-4492
A1C12	0160-4492	2	2	CAPACITOR-FXD 18PF +-5% 200VDC CER 0+-30	28480	0160-4492
A1C13	0180-0562	1	1	CAPACITOR-FXD 33UF+-20% 10VDC TA	56289	196D336X0010KA1
A1C14	0160-4040	6	18	CAPACITOR-FXD 1000PF +-5% 100VDC CER	28480	0160-4040
A1C15	0160-4040	6	6	CAPACITOR-FXD 1000PF +-5% 100VDC CER	28480	0160-4040
A1C16	0160-3875	3	2	CAPACITOR-FXD 22PF +-5% 200VDC CER 0+-30	28480	0160-3875
A1C17	0160-4040	6	6	CAPACITOR-FXD 1000PF +-5% 100VDC CER	28480	0160-4040
A1C18	0160-4518	3	1	CAPACITOR-FXD 3.9PF +- .5PF 200VDC CER	28480	0160-4518
A1C19	0160-4040	6	6	CAPACITOR-FXD 1000PF +-5% 100VDC CER	28480	0160-4040
A1C20	0160-4040	6	6	CAPACITOR-FXD 1000PF +-5% 100VDC CER	28480	0160-4040
A1C21	0160-3879	7	7	CAPACITOR-FXD .01UF +-20% 100VDC CER	28480	0160-3879
A1C22	0160-4040	6	6	CAPACITOR-FXD 1000PF +-5% 100VDC CER	28480	0160-4040
A1C23	0160-4040	6	6	CAPACITOR-FXD 1000PF +-5% 100VDC CER	28480	0160-4040
A1C24				NOT ASSIGNED		
A1C25	0160-4040	6	6	CAPACITOR-FXD 1000PF +-5% 100VDC CER	28480	0160-4040
A1C26	0160-4040	6	6	CAPACITOR-FXD 1000PF +-5% 100VDC CER	28480	0160-4040
A1C27	0160-4554	7	8	CAPACITOR-FXD .01UF +-20% 50VDC CER	28480	0160-4554
A1C28	0160-0127	2	3	CAPACITOR-FXD 1UF +-20% 25VDC CER	28480	0160-0127
A1C29	0180-3276	0	2	CAPACITOR-FXD 2200UF+100-10% 25VDC AL	28480	0180-3276
A1C30	0180-3276	0	0	CAPACITOR-FXD 2200UF+100-10% 25VDC AL	28480	0180-3276
A1C31	0180-0228	6	1	CAPACITOR-FXD 22UF+-10% 15VDC TA	56289	150D226X9015B2
A1C32	0160-4557	0	1	CAPACITOR-FXD .1UF +-20% 50VDC CER	16299	CAC04X7R104M050A
A1C33	0160-0576	5	6	CAPACITOR-FXD .1UF +-20% 50VDC CER	28480	0160-0576
A1C34	0160-4819	7	2	CAPACITOR-FXD 2200PF +-5% 100VDC CER	28480	0160-4819
A1C35	0160-4822	2	3	CAPACITOR-FXD 1000PF +-5% 100VDC CER	28480	0160-4822
A1C36	0180-3279	3	1	CAPACITOR-FXD 390UF+100-10% 12VDC AL	28480	0180-3279
A1C37	0160-3879	7	7	CAPACITOR-FXD .01UF +-20% 100VDC CER	28480	0160-3879
A1C38				NOT ASSIGNED		
A1C39	0160-0576	5	5	CAPACITOR-FXD .1UF +-20% 50VDC CER	28480	0160-0576
A1C40	0180-0291	3	3	CAPACITOR-FXD 1UF+-10% 35VDC TA	56289	150D105X9035A2
A1C41	0160-4554	7	7	CAPACITOR-FXD .01UF +-20% 50VDC CER	28480	0160-4554
A1C42	0160-4554	7	7	CAPACITOR-FXD .01UF +-20% 50VDC CER	28480	0160-4554
A1C43	0180-0291	3	3	CAPACITOR-FXD 1UF+-10% 35VDC TA	56289	150D105X9035A2
A1C44	0180-0291	3	3	CAPACITOR-FXD 1UF+-10% 35VDC TA	56289	150D105X9035A2
A1C45	0160-3879	7	7	CAPACITOR-FXD .01UF +-20% 100VDC CER	28480	0160-3879
A1C46	0160-4822	2	2	CAPACITOR-FXD 1000PF +-5% 100VDC CER	28480	0160-4822
A1C47	0160-4554	7	7	CAPACITOR-FXD .01UF +-20% 50VDC CER	28480	0160-4554
A1C48	0160-4822	2	2	CAPACITOR-FXD 1000PF +-5% 100VDC CER	28480	0160-4822
A1C49	0160-4554	7	7	CAPACITOR-FXD .01UF +-20% 50VDC CER	28480	0160-4554
A1C50	0160-4810	8	1	CAPACITOR-FXD 330PF +-5% 100VDC CER	28480	0160-4810
A1C51	0160-4554	7	7	CAPACITOR-FXD .01UF +-20% 50VDC CER	28480	0160-4554
A1C52	0160-4554	7	7	CAPACITOR-FXD .01UF +-20% 50VDC CER	28480	0160-4554
A1C53	0160-0127	2	2	CAPACITOR-FXD 1UF +-20% 25VDC CER	28480	0160-0127
A1C54	0180-0418	6	1	CAPACITOR-FXD 1UF+-20% 35VDC TA	28480	0180-0418
A1C55	0160-4808	4	3	CAPACITOR-FXD 470PF +-5% 100VDC CER	28480	0160-4808
A1C56	0160-4808	4	4	CAPACITOR-FXD 470PF +-5% 100VDC CER	28480	0160-4808
A1C57	0160-4808	4	4	CAPACITOR-FXD 470PF +-5% 100VDC CER	28480	0160-4808
A1C58	0160-4554	7	7	CAPACITOR-FXD .01UF +-20% 50VDC CER	28480	0160-4554
A1C59	0160-3879	7	7	CAPACITOR-FXD .01UF +-20% 100VDC CER	28480	0160-3879
A1C60	0160-4040	6	6	CAPACITOR-FXD 1000PF +-5% 100VDC CER	28480	0160-4040

See introduction to this section for ordering information
*Indicates factory selected value

Table 6-9. HP 5385A Replaceable Parts (Continued)

Reference Designation	HP Part Number	C D	Qty	Description	Mfr Code	Mfr Part Number
A1C61	0160-0576	5		CAPACITOR-FXD .1UF +-20% 50VDC CER	28480	0160-0576
A1C62	0160-4040	6		CAPACITOR-FXD 1000PF +-5% 100VDC CER	28480	0160-4040
A1C63	0160-3872	0	1	CAPACITOR-FXD 2.2PF +- .25PF 200VDC CER	28480	0160-3872
A1C64	0160-3875	3		CAPACITOR-FXD 22PF +-5% 200VDC CER 0+-30	28480	0160-3875
A1C65	0160-4040	6		CAPACITOR-FXD 1000PF +-5% 100VDC CER	28480	0160-4040
A1C66	0160-0576	5		CAPACITOR-FXD .1UF +-20% 50VDC CER	28480	0160-0576
A1C67	0160-3879	7		CAPACITOR-FXD .01UF +-20% 100VDC CER	28480	0160-3879
A1C68				NOT ASSIGNED		
A1C69	0160-0127	2		CAPACITOR-FXD 1UF +-20% 25VDC CER	28480	0160-0127
A1C70	0160-4819	7		CAPACITOR-FXD 2200PF +-5% 100VDC CER	28480	0160-4819
A1C71	0160-4805	1	1	CAPACITOR-FXD 47PF +-5% 100VDC CER 0+-30	28480	0160-4805
A1C72	0180-0562	1		CAPACITOR-FXD 33UF+-20% 10VDC TA	56289	196D336X0010KA1
A1C73				NOT ASSIGNED		
A1C74				NOT ASSIGNED		
A1C75	0160-0576	5		CAPACITOR-FXD .1UF +-20% 50VDC CER	28480	0160-0576
A1C76	0160-4040	6		CAPACITOR-FXD 1000PF +-5% 100VDC CER	28480	0160-4040
A1C77	0160-4040	6		CAPACITOR-FXD 1000PF +-5% 100VDC CER	28480	0160-4040
A1C78	0160-4040	6		CAPACITOR-FXD 1000PF +-5% 100VDC CER	28480	0160-4040
A1C79	0160-4040	6		CAPACITOR-FXD 1000PF +-5% 100VDC CER	28480	0160-4040
A1C80				NOT ASSIGNED		
A1C81	0160-4040	6		CAPACITOR-FXD 1000PF +-5% 100VDC CER	28480	0160-4040
A1C82	0160-4040	6		CAPACITOR-FXD 1000PF +-5% 100VDC CER	28480	0160-4040
A1C83	0160-4846	0	2	CAPACITOR-FXD 1500PF +-5% 100VDC CER	28480	0160-4846
A1C84	0160-4846	0		CAPACITOR-FXD 1500PF +-5% 100VDC CER	28480	0160-4846
A1C85	0160-0576	5		CAPACITOR-FXD .1UF +-20% 50VDC CER	28480	0160-0576
A1CR1	1901-0050	3	13	DIODE-SWITCHING 80V 200MA 2NS DO-35	28480	1901-0050
A1CR2	1901-0376	6	2	DIODE-GEN PRP 35V 50MA DO-35	28480	1901-0376
A1CR3	1901-0376	6		DIODE-GEN PRP 35V 50MA DO-35	28480	1901-0376
A1CR4	1901-0639	4	4	DIODE-PIN	28480	5082-3080
A1CR5	1901-0639	4		DIODE-PIN	28480	5082-3080
A1CR6	1901-0639	4		DIODE-PIN	28480	5082-3080
A1CR7	1901-0639	4		DIODE-PIN	28480	5082-3080
A1CR8	1906-0096	7	1	DIODE-FW BRDG 200V 2A	04713	MDA202
A1CR9	1884-0221	2	1	THYRISTOR-SCR VRRM=300	04713	MCR106-5
A1CR10	1902-3234	3	1	DIODE-ZNR 19.6V 5% DO-35 PD=.4W	28480	1902-3234
A1CR11	1901-0050	3		DIODE-SWITCHING 80V 200MA 2NS DO-35	28480	1901-0050
A1CR12	1901-0782	8	2	DIODE-SCHOTTKY 1N5821 30V 3A	04713	1N5821
A1CR13	1902-3110	4	1	DIODE-ZNR 5.9V 2% DO-35 PD=.4W TC=+.017%	28480	1902-3110
A1CR14	1901-0782	8		DIODE-SCHOTTKY 1N5821 30V 3A	04713	1N5821
A1CR15	1901-0050	3		DIODE-SWITCHING 80V 200MA 2NS DO-35	28480	1901-0050
A1CR16	1901-0050	3		DIODE-SWITCHING 80V 200MA 2NS DO-35	28480	1901-0050
A1CR17	1901-0050	3		DIODE-SWITCHING 80V 200MA 2NS DO-35	28480	1901-0050
A1CR18	1901-0050	3		DIODE-SWITCHING 80V 200MA 2NS DO-35	28480	1901-0050
A1CR19	1901-0050	3		DIODE-SWITCHING 80V 200MA 2NS DO-35	28480	1901-0050
A1CR20	1901-0050	3		DIODE-SWITCHING 80V 200MA 2NS DO-35	28480	1901-0050
A1CR21	1901-0050	3		DIODE-SWITCHING 80V 200MA 2NS DO-35	28480	1901-0050
A1CR22	1901-0050	3		DIODE-SWITCHING 80V 200MA 2NS DO-35	28480	1901-0050
A1CR23	1901-0050	3		DIODE-SWITCHING 80V 200MA 2NS DO-35	28480	1901-0050
A1CR24	1901-0179	7	2	DIODE-SWITCHING 15V 50MA 750PS DO-7	28480	1901-0179
A1CR25	1901-0179	7		DIODE-SWITCHING 15V 50MA 750PS DO-7	28480	1901-0179
A1CR26	1901-1068	5	2	DIODE-SM SIG SCHOTTKY	28480	1901-1068
A1CR27	1901-0050	3		DIODE-SWITCHING 80V 200MA 2NS DO-35	28480	1901-0050
A1CR28	1901-0050	3		DIODE-SWITCHING 80V 200MA 2NS DO-35	28480	1901-0050
A1CR29	1901-1068	5		DIODE-SM SIG SCHOTTKY	28480	1901-1068
A1CR30	1902-0126	6	1	DIODE-ZNR 2.61V 5% DO-7 PD=.4W TC=-.072%	28480	1902-0126
A1E1	9170-0029	3	1	CORE-SHIELDING BEAD	28480	9170-0029
A1F1	2110-0201	0	1	FUSE .25A 250V TD 1.25X.25 UL	28480	2110-0201
A1F1	2110-0565	9	1	FUSEHOLDER CAP 12A MAX FOR UL	28480	2110-0565
A1F2	2110-0002	9	1	FUSE 2A 250V NTD 1.25X.25 UL	75915	312002
A1F3	2110-0301	1	1	FUSE .125A 125V .281X.093	28480	2110-0301
A1J1	1250-1782	9	1	CONNECTOR-RF BNC FEM PCH-PNL 50-OHM	28480	1250-1782
A1J2	1250-1824	0	1	BNC FUSED PC MU	28480	1250-1824
A1J3	1251-4743	0	1	CONNECTOR-AC PUR HP-9 MALE REC-FLG THRM P	28480	1251-4743
A1J4	1251-8261	5	1	JACK POWER PCB HT	28480	1251-8261
A1J5	1250-1842	2	1	BNC RTANG PC MNT	28480	1250-1842

See introduction to this section for ordering information
*Indicates factory selected value

HP 5384A and HP 5385A
Replaceable Parts

Table 6-9. HP 5385A Replaceable Parts (Continued)

Reference Designation	HP Part Number	C D	Qty	Description	Mfr Code	Mfr Part Number
A1J6	1251-8304	7	1	CONN-POST TYPE .100-PIN-SPCG 8-CONT	28480	1251-8304
A1J7				NOT ASSIGNED		
A1J8	1251-7684	4	1	CABLE ASSY 14 POST	28480	1251-7684
A1J9	1251-8139	6	1	CONN-POST TYPE .100-PIN-SPCG 14-CONT	28480	1251-8139
A1K1	0490-1317	3	1	RELAY-REED 1C 250MA 200VDC 5VDC-COIL 3VA	28480	0490-1317
A1L1	9140-0718	4	1	INDUCTOR-FIXED NORM IND: 230UH @ 1.5ADC	28480	9140-0718
A1L2	9100-1788	6	9	CORE-FERRITE CHOKE-WIDEBAND; IMP:>680	28480	9100-1788
A1L3	9140-0531	9	2	INDUCTOR RF-CH-MLD 1UH 5% .10SDX.26LG	28480	9140-0531
A1L4	9100-2562	6	1	INDUCTOR RF-CH-MLD 100UH 10%	28480	9100-2562
A1L5				NOT ASSIGNED		
A1L6	9100-1788	6		CORE-FERRITE CHOKE-WIDEBAND; IMP:>680	28480	9100-1788
A1L7	9100-1788	6		CORE-FERRITE CHOKE-WIDEBAND; IMP:>680	28480	9100-1788
A1L8				NOT ASSIGNED		
A1L9	9100-1788	6		CORE-FERRITE CHOKE-WIDEBAND; IMP:>680	28480	9100-1788
A1L10	9100-2817	4	2	INDUCTOR RF-CH-MLD 100NH 5% .10SDX.26LG	28480	9100-2817
A1L11	9100-1788	6		CORE-FERRITE CHOKE-WIDEBAND; IMP:>680	28480	9100-1788
A1L12	9100-2817	4		INDUCTOR RF-CH-MLD 100NH 5% .10SDX.26LG	28480	9100-2817
A1L13	9100-1788	6		CORE-FERRITE CHOKE-WIDEBAND; IMP:>680	28480	9100-1788
A1L14	9140-0521	7	1	INDUCTOR RF-CH-MLD 300NH 5% .10SDX.26LG	28480	9140-0521
A1L15	9140-0310	2	1	INDUCTOR RF-CH-MLD 390NH 5% .10SDX.26LG	28480	9140-0310
A1L16	9100-1788	6		CORE-FERRITE CHOKE-WIDEBAND; IMP:>680	28480	9100-1788
A1L17	9100-1788	6		CORE-FERRITE CHOKE-WIDEBAND; IMP:>680	28480	9100-1788
A1L18	9100-1788	6		CORE-FERRITE CHOKE-WIDEBAND; IMP:>680	28480	9100-1788
A1L19	9140-0531	9		INDUCTOR RF-CH-MLD 1UH 5% .10SDX.26LG	28480	9140-0531
A1Q1	1854-0215	1	2	TRANSISTOR NPN SI PD=350MW FT=300MHZ	04713	2N3904
A1Q2	1855-0327	8	1	TRANSISTOR J-FET 2N4416 N-CHAN D-MODE	01295	2N4416
A1Q3	1853-0354	7	1	TRANSISTOR PNP SI TO-92 PD=350MW	28480	1853-0354
A1Q4	1855-0414	4	1	TRANSISTOR J-FET 2N4393 N-CHAN D-MODE	04713	2N4393
A1Q5	1854-0215	1		TRANSISTOR NPN SI PD=350MW FT=300MHZ	04713	2N3904
A1Q6				NOT ASSIGNED		
A1Q7				NOT ASSIGNED		
A1Q8	1853-0015	7	2	TRANSISTOR PNP SI PD=200MW FT=500MHZ	28480	1853-0015
A1Q9	1853-0015	7		TRANSISTOR PNP SI PD=200MW FT=500MHZ	28480	1853-0015
A1Q10	1853-0363	8	1	TRANSISTOR PNP SI PD=50W FT=20MHZ	03508	X45H281
A1Q11	1854-0013	7	1	TRANSISTOR NPN 2N2218A SI TO-5 PD=800MW	04713	2N2218A
A1Q12	1854-0477	7	1	TRANSISTOR NPN 2N2222A SI TO-18 PD=500MW	04713	2N2222A
A1R1	0698-8827	4	4	RESISTOR 1M 1% .125W F TC=0+-100	28480	0698-8827
A1R2	0757-0706	8	1	RESISTOR 51.1 1% .25W F TC=0+-100	24546	C5-1/4-T0-51R1-F
A1R3	0698-8827	4		RESISTOR 1M 1% .125W F TC=0+-100	28480	0698-8827
A1R4	0699-0071	6	2	RESISTOR 4.64M 1% .125W F TC=0+-100	28480	0699-0071
A1R5	0698-7276	5	1	RESISTOR 46.4K 1% .05W F TC=0+-100	24546	C3-1/8-T0-4642-F
A1R6	0757-0346	2	2	RESISTOR 10 1% .125W F TC=0+-100	24546	C4-1/8-T0-10R0-F
A1R7	0757-0421	4	4	RESISTOR 825 1% .125W F TC=0+-100	24546	C4-1/8-T0-825R-F
A1R8	0698-3445	2	2	RESISTOR 348 1% .125W F TC=0+-100	24546	C4-1/8-T0-348R-F
A1R9	0698-7236	7	1	RESISTOR 1K 1% .05W F TC=0+-100	24546	C3-1/8-T0-1001-F
A1R10	0698-7233	4	1	RESISTOR 750 1% .05W F TC=0+-100	24546	C3-1/8-T0-750R-F
A1R11	0698-7283	4	1	RESISTOR 90.9K 1% .05W F TC=0+-100	24546	C3-1/8-T0-9092-F
A1R12	0698-8812	7	1	RESISTOR 1 1% .125W F TC=0+-100	28480	0698-8812
A1R13	0698-3136	8	1	RESISTOR 17.8K 1% .125W F TC=0+-100	24546	C4-1/8-T0-1782-F
A1R14	0698-7244	7	1	RESISTOR 2.15K 1% .05W F TC=0+-100	24546	C3-1/8-T0-2151-F
A1R15	0698-3447	4	3	RESISTOR 422 1% .125W F TC=0+-100	24546	C4-1/8-T0-422R-F
A1R16	0698-3447	4		RESISTOR 422 1% .125W F TC=0+-100	24546	C4-1/8-T0-422R-F
A1R17	1810-0541	4	1	NETWORK-RES 6-SIP MULTII-VALUE	28480	1810-0541
A1R18	1810-0219	3	1	NETWORK-RES 8-SIP220.0 OHM X 4	01121	208B221
A1R19	0698-7220	9	2	RESISTOR 215 1% .05W F TC=0+-100	24546	C3-1/8-T0-215R-F
A1R20	0698-7220	9		RESISTOR 215 1% .05W F TC=0+-100	24546	C3-1/8-T0-215R-F
A1R21	0698-7249	2	2	RESISTOR 3.48K 1% .05W F TC=0+-100	24546	C3-1/8-T0-3481-F
A1R22	0698-0084	9	1	RESISTOR 2.15K 1% .125W F TC=0+-100	24546	C4-1/8-T0-2151-F
A1R23	0757-0394	0	3	RESISTOR 51.1 1% .125W F TC=0+-100	24546	C4-1/8-T0-51R1-F
A1R24	0757-0394	0		RESISTOR 51.1 1% .125W F TC=0+-100	24546	C4-1/8-T0-51R1-F
A1R25	0698-3132	4	4	RESISTOR 261 1% .125W F TC=0+-100	24546	C4-1/8-T0-2610-F
A1R26	0757-0416	7	6	RESISTOR 511 1% .125W F TC=0+-100	24546	C4-1/8-T0-511R-F
A1R27	0757-0416	7		RESISTOR 511 1% .125W F TC=0+-100	24546	C4-1/8-T0-511R-F
A1R28	0698-3439	4	3	RESISTOR 178 1% .125W F TC=0+-100	24546	C4-1/8-T0-178R-F
A1R29	0698-8957	1	1	RESISTOR 500K 1% .125W F TC=0+-100	28480	0698-8957
A1R30	0698-3439	4		RESISTOR 178 1% .125W F TC=0+-100	24546	C4-1/8-T0-178R-F

See introduction to this section for ordering information
*Indicates factory selected value

Table 6-9. HP 5385A Replaceable Parts (Continued)

Reference Designation	HP Part Number	C D	Qty	Description	Mfr Code	Mfr Part Number
A1R31	0698-8827	4		RESISTOR 1M 1% .125W F TC=0+-100	28480	0698-8827
A1R32	0757-0442	9	5	RESISTOR 10K 1% .125W F TC=0+-100	24546	C4-1/8-T0-1002-F
A1R33	0757-0442	9		RESISTOR 10K 1% .125W F TC=0+-100	24546	C4-1/8-T0-1002-F
A1R34	2100-1788	9	1	RESISTOR-TRMR 500 10% C TOP-ADJ 1-TRN	73138	82PR500
A1R35	0757-0280	3	3	RESISTOR 1K 1% .125W F TC=0+-100	24546	C4-1/8-T0-1001-F
A1R36	0698-3439	4		RESISTOR 178 1% .125W F TC=0+-100	24546	C4-1/8-T0-178R-F
A1R37	0698-3155	1	1	RESISTOR 4.64K 1% .125W F TC=0+-100	24546	C4-1/8-T0-4641-F
A1R38	0757-0421	4		RESISTOR 825 1% .125W F TC=0+-100	24546	C4-1/8-T0-825R-F
A1R39	0757-0442	9		RESISTOR 10K 1% .125W F TC=0+-100	24546	C4-1/8-T0-1002-F
A1R40	0757-0442	9		RESISTOR 10K 1% .125W F TC=0+-100	24546	C4-1/8-T0-1002-F
A1R41	0698-3156	2	2	RESISTOR 14.7K 1% .125W F TC=0+-100	24546	C4-1/8-T0-1472-F
A1R42	0698-8827	4		RESISTOR 1M 1% .125W F TC=0+-100	28480	0698-8827
A1R43	2100-0558	9	1	RESISTOR-TRMR 20K 10% C TOP-ADJ 1-TRN	28480	2100-0558
A1R44	0757-0199	3	1	RESISTOR 21.5K 1% .125W F TC=0+-100	24546	C4-1/8-T0-2152-F
A1R45- A1R48			1	NOT ASSIGNED		
A1R49	1810-0488	8	1	NETWORK-RES 8-SIP4.7K OHM X 4	28480	1810-0488
A1R50	0812-0021	8	1	RESISTOR .47 5% 3W PW TC=0+-90	91637	CW2B1-3-T2-47/100-J
A1R51				NOT ASSIGNED		
A1R52	0757-0394	0		RESISTOR 51.1 1% .125W F TC=0+-100	24546	C4-1/8-T0-51R1-F
A1R53	0698-3132	4		RESISTOR 261 1% .125W F TC=0+-100	24546	C4-1/8-T0-2610-F
A1R54	0757-1093	8	2	RESISTOR 3K 1% .125W F TC=0+-100	24546	C4-1/8-T0-3001-F
A1R55	0757-0465	6	2	RESISTOR 100K 1% .125W F TC=0+-100	24546	C4-1/8-T0-1003-F
A1R56	0757-0407	6	1	RESISTOR 200 1% .125W F TC=0+-100	24546	C4-1/8-T0-201-F
A1R57	0757-0289	2	1	RESISTOR 13.3K 1% .125W F TC=0+-100	19701	MF4C1/8-T0-1332-F
A1R58	0757-0399	5	1	RESISTOR 82.5 1% .125W F TC=0+-100	24546	C4-1/8-T0-82R5-F
A1R59	0757-0416	7		RESISTOR 511 1% .125W F TC=0+-100	24546	C4-1/8-T0-511R-F
A1R60	0757-0346	2		RESISTOR 10 1% .125W F TC=0+-100	24546	C4-1/8-T0-10R0-F
A1R61	0698-3398	4	1	RESISTOR 46.4 1% .5W F TC=0+-100	28480	0698-3398
A1R62	0757-0200	7	2	RESISTOR 5.62K 1% .125W F TC=0+-100	24546	C4-1/8-T0-5621-F
A1R63	0757-0200	7		RESISTOR 5.62K 1% .125W F TC=0+-100	24546	C4-1/8-T0-5621-F
A1R64	0699-0071	6		RESISTOR 4.64M 1% .125W F TC=0+-100	28480	0699-0071
A1R65	1810-0370	7	1	NETWORK-RES 8-SIP220.0 OHM X 7	01121	208A221
A1R66	0698-7505	8	1	RESISTOR 75 5% .5W CC TC=0+412	01121	EB7505
A1R67	0757-0442	9		RESISTOR 10K 1% .125W F TC=0+-100	24546	C4-1/8-T0-1002-F
A1R68	0757-0405	4	2	RESISTOR 162 1% .125W F TC=0+-100	24546	C4-1/8-T0-162R-F
A1R69	0757-0405	4		RESISTOR 162 1% .125W F TC=0+-100	24546	C4-1/8-T0-162R-F
A1R70	0698-7212	9	2	RESISTOR 100 1% .05W F TC=0+-100	24546	C3-1/8-T0-100R-F
A1R71	0698-7212	9		RESISTOR 100 1% .05W F TC=0+-100	24546	C3-1/8-T0-100R-F
A1R72	0698-3156	2		RESISTOR 14.7K 1% .125W F TC=0+-100	24546	C4-1/8-T0-1472-F
A1R73	0698-7197	9	1	RESISTOR 23.7 1% .05W F TC=0+-100	24546	C3-1/8-T0-23R7-F
A1R74	0698-7219	6	1	RESISTOR 196 1% .05W F TC=0+-100	24546	C3-1/8-T0-196P-F
A1R75	0757-0420	3	2	RESISTOR 750 1% .125W F TC=0+-100	24546	C4-1/8-T0-751-F
A1R76	0757-0419	0	1	RESISTOR 681 1% .125W F TC=0+-100	24546	C4-1/8-T0-681R-F
A1R77	2100-0554	5	1	RESISTOR-TRMR 500 10% C TOP-ADJ 1-TRN	28480	2100-0554
A1R78	0757-0465	6		RESISTOR 100K 1% .125W F TC=0+-100	24546	C4-1/8-T0-1003-F
A1R79	0757-0420	3		RESISTOR 750 1% .125W F TC=0+-100	24546	C4-1/8-T0-751-F
A1R80	0698-0082	7	5	RESISTOR 464 1% .125W F TC=0+-100	24546	C4-1/8-T0-4640-F
A1R81	0698-0082	7		RESISTOR 464 1% .125W F TC=0+-100	24546	C4-1/8-T0-4640-F
A1R82	0757-0283	6	2	RESISTOR 2K 1% .125W F TC=0+-100	24546	C4-1/8-T0-2001-F
A1R83	0757-1093	8		RESISTOR 3K 1% .125W F TC=0+-100	24546	C4-1/8-T0-3001-F
A1R84	0698-0082	7		RESISTOR 464 1% .125W F TC=0+-100	24546	C4-1/8-T0-4640-F
A1R85	0698-0082	7		RESISTOR 464 1% .125W F TC=0+-100	24546	C4-1/8-T0-4640-F
A1R86	0698-3445	2		RESISTOR 348 1% .125W F TC=0+-100	24546	C4-1/8-T0-348R-F
A1R87	0757-0421	4		RESISTOR 825 1% .125W F TC=0+-100	24546	C4-1/8-T0-825R-F
A1R88	0757-0421	4		RESISTOR 825 1% .125W F TC=0+-100	24546	C4-1/8-T0-825R-F
A1R89	0698-3460	1	1	RESISTOR 422K 1% .125W F TC=0+-100	28480	0698-3460
A1R90	0757-0416	7		RESISTOR 511 1% .125W F TC=0+-100	24546	C4-1/8-T0-511R-F
A1R91	0698-3132	4		RESISTOR 261 1% .125W F TC=0+-100	24546	C4-1/8-T0-2610-F
A1R92	0698-3132	4		RESISTOR 261 1% .125W F TC=0+-100	24546	C4-1/8-T0-2610-F
A1R93	0757-0280	3		RESISTOR 1K 1% .125W F TC=0+-100	24546	C4-1/8-T0-1001-F
A1R94	0698-7229	8	1	RESISTOR 511 1% .05W F TC=0+-100	24546	C3-1/8-T0-511R-F
A1R95	0757-0416	7		RESISTOR 511 1% .125W F TC=0+-100	24546	C4-1/8-T0-511R-F
A1R96	0698-7249	2		RESISTOR 3.48K 1% .05W F TC=0+-100	24546	C3-1/8-T0-3481-F
A1R97	0698-5808	5	1	RESISTOR 4K 1% .125W F TC=0+-100	24546	C4-1/8-T0-4001-F
A1R98- A1R100				NOT ASSIGNED		

See introduction to this section for ordering information
*Indicates factory selected value

HP 5384A and HP 5385A
Replaceable Parts

Table 6-9. HP 5385A Replaceable Parts (Continued)

Reference Designation	HP Part Number	C D	Qty	Description	Mfr Code	Mfr Part Number
A1R101	0698-3447	4		RESISTOR 422 1% .125W F TC=0+-100	24546	C4-1/8-T0-422R-F
A1R102	0757-0280	3		RESISTOR 1K 1% .125W F TC=0+-100	24546	C4-1/8-T0-1001-F
A1R103	0757-0416	7		RESISTOR 511 1% .125W F TC=0+-100	24546	C4-1/8-T0-511R-F
A1R104	0698-3152	8	1	RESISTOR 3.48K 1% .125W F TC=0+-100	24546	C4-1/8-T0-3481-F
A1R105	0757-0283	6		RESISTOR 2K 1% .125W F TC=0+-100	24546	C4-1/8-T0-2001-F
A1R106	0837-0220	1	1	THERMISTOR ROD 10K-OHM TC=-3.83%/C-DEG	28480	0837-0220
A1R107	1810-0368	3	1	NETWORK-RES 6-SIP10.0K OHM X 5	01121	206A103
A1R108	0698-0082	7		RESISTOR 464 1% .125W F TC=0+-100	24546	C4-1/8-T0-4640-F
A1R109	0757-0401	0	1	RESISTOR 100 1% .125W F TC=0+-100	24546	C4-1/8-T0-101-F
A1S1	3101-2656	5	1	SS LIN SEL 90PC	28480	3101-2656
A1S2	3101-2644	1	1	SWITCH-PB DPDT ALTNG .5A 100VAC	28480	3101-2644
A1S3	3101-2453	0	1	SWITCH-TGL SUBMIN DPDT .02A 20VAC/DC PC	28480	3101-2453
A1TP1	1251-0600	0	13	CONNECTOR-SGL CONT PIN 1.14-MM-BSC-SZ SQ	28480	1251-0600
A1TP2	1251-0600	0		CONNECTOR-SGL CONT PIN 1.14-MM-BSC-SZ SQ	28480	1251-0600
A1TP3	1251-0600	0		CONNECTOR-SGL CONT PIN 1.14-MM-BSC-SZ SQ	28480	1251-0600
A1TP4	1251-0600	0		CONNECTOR-SGL CONT PIN 1.14-MM-BSC-SZ SQ	28480	1251-0600
A1TP5	1251-0600	0		CONNECTOR-SGL CONT PIN 1.14-MM-BSC-SZ SQ	28480	1251-0600
A1TP6	1251-0600	0		CONNECTOR-SGL CONT PIN 1.14-MM-BSC-SZ SQ	28480	1251-0600
A1TP7	1251-0600	0		CONNECTOR-SGL CONT PIN 1.14-MM-BSC-SZ SQ	28480	1251-0600
A1TP8	1251-0600	0		CONNECTOR-SGL CONT PIN 1.14-MM-BSC-SZ SQ	28480	1251-0600
A1TP9	1251-0600	0		CONNECTOR-SGL CONT PIN 1.14-MM-BSC-SZ SQ	28480	1251-0600
A1TP10	1251-0600	0		CONNECTOR-SGL CONT PIN 1.14-MM-BSC-SZ SQ	28480	1251-0600
A1TP11	1251-0600	0		CONNECTOR-SGL CONT PIN 1.14-MM-BSC-SZ SQ	28480	1251-0600
A1TP12	1251-0600	0		CONNECTOR-SGL CONT PIN 1.14-MM-BSC-SZ SQ	28480	1251-0600
A1TP13	1251-0600	0		CONNECTOR-SGL CONT PIN 1.14-MM-BSC-SZ SQ	28480	1251-0600
A1U1	1820-2312	2	1	IC MISC	28480	1820-2312
A1U2	1820-3572	8	1	IC-MCU W/ROM/RAM; 4MHZ	28480	1820-3572
A1U3	1820-3075	6	1	IC RCVR ECL/10KH LINE RCVR TPL	28480	1820-3075
A1U4	1813-0217	7	3	IC WIDEBAND AMPL T0-39 PKG	04713	MWA310
A1U5	1813-0217	7		IC WIDEBAND AMPL T0-39 PKG	04713	MWA310
A1U6	1858-0040	8	1	TRANSISTOR ARRAY 16-PIN PLSTC DIP	3L585	CA3127E
A1U7	1826-0904	6	1	IC-LM330T-5.0	28480	1826-0904
A1U8	1826-0544	0	1	IC V RGLTR-V-REF-FXD 2.5V 8-DIP-C PKG	28480	1826-0544
A1U9	1826-0428	9	1	IC 3524 MODULATOR 16-DIP-C	01295	SG3524J
A1U10	1826-0393	7	1	IC V RGLTR-ADJ-POS 1.2/37V T0-220 PKG	28480	1826-0393
A1U11	1858-0054	4	1	TRANSISTOR ARRAY 16-PIN PLSTC DIP	28480	1858-0054
A1U12	1826-0065	0	1	IC COMPARATOR PRON 8-DIP-P PKG	S0545	UPC311C
A1U13	1820-1425	6	1	IC SCHMITT-TRIG TTL LS NAND QUAD 2-INP	01295	SN74LS132N
A1U14	1820-2096	9	1	IC CNTR TTL LS BIN DUAL 4-BIT	01295	SN74LS393N
A1U15	1820-1975	1	1	IC SHF-RGTR TTL LS NEG-EDGE-TRIG PRL-IN	01295	SN74LS165N
A1U16	1813-0217	7		IC WIDEBAND AMPL T0-39 PKG	04713	MWA310
A1U17	1826-0501	9	1	IC MULTIPLXR 2-CHAN-ANLG TRIPLE 16-DIP-P	04713	MC14053BCP
A1U18	1826-0161	7	1	IC OP AMP GP QUAD 14-DIP-P PKG	04713	LM324P
A1U19	1820-2904	8	1	IC PRESER ECL	28480	1820-2904
A1W1	8120-4038	6	1	FLAT RIBBON ASSY 8-COND 2.5-IN-LG	28480	8120-4038
A1XU1	1200-0654	7	2	SOCKET-IC 40-CONT DIP DIP-SLDR	28480	1200-0654
A1XU2	1200-0654	7		SOCKET-IC 40-CONT DIP DIP-SLDR	28480	1200-0654
A1XW1	1200-0473	8	1	SOCKET-IC 16-CONT DIP DIP-SLDR	28480	1200-0473
A1Y1A	0960-0636	4	1	OVEN-OSCILLATOR MODULE FREQ: 10 MHZ	28480	0960-0636
A1Y1B	0960-0612	6	1	CRYSTAL-OSCILLATOR 10.0 MHZ; 0-55 DEG C	28480	0960-0612
R1	2100-2083	9	1	RESISTOR-VAR CONTROL CCP 20K 20% LIN	28480	2100-2083
W1	8120-1378	1	1	CABLE ASSY 18AWG 3-CNDCT JGK-JKT	28480	8120-1378
W3	8150-0450	1	1	WIRE 24AWG 0 300V PVC 7X32 80C	28480	8150-0450
W4	8150-0449	8	1	WIRE 24AWG R 300V PVC 7X32 80C	28480	8150-0449
W5	8150-0448	7	1	WIRE 24AWG BR 300V PVC 7X32 80C	28480	8150-0448
W6	8150-2846	3	1	WIRE 18AWG G/Y 300V PVC 14X30 105C	28480	8150-2846

See introduction to this section for ordering information
*Indicates factory selected value

Table 6-9. HP 5385A Replaceable Parts (Continued)

Reference Designation	HP Part Number	C D	Qty	Description	Mfr Code	Mfr Part Number
XF1	2110-0269	0	1	FUSEHOLDER-CLIP TYPE, 25D-FUSE	28480	2110-0269
XF2	2110-0642	3	1	FUSEHOLDER-EXTR POST 6.3A 250V BAY CAP	28480	2110-0642

See introduction to this section for ordering information
*Indicates factory selected value

HP 5384A and HP 5385A
Replaceable Parts

Table 6-10. HP 5385A With Oven Oscillator Replaceable Parts

Reference Designation	HP Part Number	C D	Qty	Description	Mfr Code	Mfr Part Number
A1	05385-60003	9	1	BOARD ASSEMBLY-MAIN (OVEN) (2430)	28480	05385-60003
A1C1	0160-4704	9	1	CAPACITOR-FXD .01UF +-10% 500VDC CER	28480	0160-4704
A1C2	0160-5649	3	1	CAPACITOR-FXD 100PF +-5% 500VDC CER	28480	0160-5649
A1C3	0160-4385	2	1	CAPACITOR-FXD 15PF +-5% 200VDC CER 0+-30	28480	0160-4385
A1C4	0180-2816	2	1	CAPACITOR-FXD 68UF+-20% 10VDC TA	28480	0180-2816
A1C5	0180-0562	1	4	CAPACITOR-FXD 33UF+-20% 10VDC TA	56289	196D336X0010KA1
A1C6	0160-0573	2	1	CAPACITOR-FXD 4700PF +-20% 100VDC CER	28480	0160-0573
A1C7	0180-0562	1	1	CAPACITOR-FXD 33UF+-20% 10VDC TA	56289	196D336X0010KA1
A1C8	0160-0572	1	1	CAPACITOR-FXD 2200PF +-20% 100VDC CER	28480	0160-0572
A1C9	0160-3879	7	6	CAPACITOR-FXD .01UF +-20% 100VDC CER	28480	0160-3879
A1C10	0160-3879	7	7	CAPACITOR-FXD .01UF +-20% 100VDC CER	28480	0160-3879
A1C11	0160-4492	2	2	CAPACITOR-FXD 18PF +-5% 200VDC CER 0+-30	28480	0160-4492
A1C12	0160-4492	2	2	CAPACITOR-FXD 18PF +-5% 200VDC CER 0+-30	28480	0160-4492
A1C13	0180-0562	1	1	CAPACITOR-FXD 33UF+-20% 10VDC TA	56289	196D336X0010KA1
A1C14	0160-4040	6	18	CAPACITOR-FXD 1000PF +-5% 100VDC CER	28480	0160-4040
A1C15	0160-4040	6	6	CAPACITOR-FXD 1000PF +-5% 100VDC CER	28480	0160-4040
A1C16	0160-3875	3	2	CAPACITOR-FXD 22PF +-5% 200VDC CER 0+-30	28480	0160-3875
A1C17	0160-4040	6	6	CAPACITOR-FXD 1000PF +-5% 100VDC CER	28480	0160-4040
A1C18	0160-4518	3	1	CAPACITOR-FXD 3.9PF +- .5PF 200VDC CER	28480	0160-4518
A1C19	0160-4040	6	6	CAPACITOR-FXD 1000PF +-5% 100VDC CER	28480	0160-4040
A1C20	0160-4040	6	6	CAPACITOR-FXD 1000PF +-5% 100VDC CER	28480	0160-4040
A1C21	0160-3879	7	7	CAPACITOR-FXD .01UF +-20% 100VDC CER	28480	0160-3879
A1C22	0160-4040	6	6	CAPACITOR-FXD 1000PF +-5% 100VDC CER	28480	0160-4040
A1C23	0160-4040	6	6	CAPACITOR-FXD 1000PF +-5% 100VDC CER	28480	0160-4040
A1C24				NOT ASSIGNED		
A1C25	0160-4040	6	6	CAPACITOR-FXD 1000PF +-5% 100VDC CER	28480	0160-4040
A1C26	0160-4040	6	6	CAPACITOR-FXD 1000PF +-5% 100VDC CER	28480	0160-4040
A1C27	0160-4554	7	8	CAPACITOR-FXD .01UF +-20% 50VDC CER	28480	0160-4554
A1C28	0160-0127	2	3	CAPACITOR-FXD 1UF +-20% 25VDC CER	28480	0160-0127
A1C29	0180-3276	0	2	CAPACITOR-FXD 2200UF+100-10% 25VDC AL	28480	0180-3276
A1C30	0180-3276	0	0	CAPACITOR-FXD 2200UF+100-10% 25VDC AL	28480	0180-3276
A1C31	0180-0228	6	1	CAPACITOR-FXD 22UF+-10% 15VDC TA	56289	150D226X9015B2
A1C32	0160-4557	0	1	CAPACITOR-FXD .1UF +-20% 50VDC CER	16299	CAC04X7R104M050A
A1C33	0160-0576	5	6	CAPACITOR-FXD .1UF +-20% 50VDC CER	28480	0160-0576
A1C34	0160-4819	7	2	CAPACITOR-FXD 2200PF +-5% 100VDC CER	28480	0160-4819
A1C35	0160-4822	2	3	CAPACITOR-FXD 1000PF +-5% 100VDC CER	28480	0160-4822
A1C36	0180-3279	3	1	CAPACITOR-FXD 390UF+100-10% 12VDC AL	28480	0180-3279
A1C37	0160-3879	7	7	CAPACITOR-FXD .01UF +-20% 100VDC CER	28480	0160-3879
A1C38				NOT ASSIGNED		
A1C39	0160-0576	5	5	CAPACITOR-FXD .1UF +-20% 50VDC CER	28480	0160-0576
A1C40	0180-0291	3	3	CAPACITOR-FXD 1UF+-10% 35VDC TA	56289	150D105X9035A2
A1C41	0160-4554	7	7	CAPACITOR-FXD .01UF +-20% 50VDC CER	28480	0160-4554
A1C42	0160-4554	7	7	CAPACITOR-FXD .01UF +-20% 50VDC CER	28480	0160-4554
A1C43	0180-0291	3	3	CAPACITOR-FXD 1UF+-10% 35VDC TA	56289	150D105X9035A2
A1C44	0180-0291	3	3	CAPACITOR-FXD 1UF+-10% 35VDC TA	56289	150D105X9035A2
A1C45	0160-3879	7	7	CAPACITOR-FXD .01UF +-20% 100VDC CER	28480	0160-3879
A1C46	0160-4822	2	2	CAPACITOR-FXD 1000PF +-5% 100VDC CER	28480	0160-4822
A1C47	0160-4554	7	7	CAPACITOR-FXD .01UF +-20% 50VDC CER	28480	0160-4554
A1C48	0160-4822	2	2	CAPACITOR-FXD 1000PF +-5% 100VDC CER	28480	0160-4822
A1C49				NOT ASSIGNED		
A1C50	0160-4810	8	1	CAPACITOR-FXD 330PF +-5% 100VDC CER	28480	0160-4810
A1C51	0160-4554	7	7	CAPACITOR-FXD .01UF +-20% 50VDC CER	28480	0160-4554
A1C52	0160-4554	7	7	CAPACITOR-FXD .01UF +-20% 50VDC CER	28480	0160-4554
A1C53	0160-0127	2	2	CAPACITOR-FXD 1UF +-20% 25VDC CER	28480	0160-0127
A1C54	0180-2698	8	1	CAPACITOR-FXD 4.7UF+-10% 35VDC TA	28480	0180-2698
A1C55	0160-4808	4	3	CAPACITOR-FXD 470PF +-5% 100VDC CER	28480	0160-4808
A1C56	0160-4808	4	4	CAPACITOR-FXD 470PF +-5% 100VDC CER	28480	0160-4808
A1C57	0160-4808	4	4	CAPACITOR-FXD 470PF +-5% 100VDC CER	28480	0160-4808
A1C58	0160-4554	7	7	CAPACITOR-FXD .01UF +-20% 50VDC CER	28480	0160-4554
A1C59	0160-3879	7	7	CAPACITOR-FXD .01UF +-20% 100VDC CER	28480	0160-3879
A1C60	0160-4040	6	6	CAPACITOR-FXD 1000PF +-5% 100VDC CER	28480	0160-4040

See introduction to this section for ordering information
*Indicates factory selected value

Table 6-10. HP 5385A With Oven Oscillator Replaceable Parts (Continued)

Reference Designation	HP Part Number	C D	Qty	Description	Mfr Code	Mfr Part Number
A1C61	0160-0576	5		CAPACITOR-FXD .1UF +-20% 50VDC CER	28480	0160-0576
A1C62	0160-4040	6		CAPACITOR-FXD 1000PF +-5% 100VDC CER	28480	0160-4040
A1C63	0160-3872	0	1	CAPACITOR-FXD 2.2PF +- .25PF 200VDC CER	28480	0160-3872
A1C64	0160-3875	3		CAPACITOR-FXD 22PF +-5% 200VDC CER 0+-30	28480	0160-3875
A1C65	0160-4040	6		CAPACITOR-FXD 1000PF +-5% 100VDC CER	28480	0160-4040
A1C66	0160-0576	5		CAPACITOR-FXD .1UF +-20% 50VDC CER	28480	0160-0576
A1C67				NOT ASSIGNED		
A1C68	0160-4554	7		CAPACITOR-FXD .01UF +-20% 50VDC CER	28480	0160-4554
A1C69	0160-0127	2		CAPACITOR-FXD 1UF +-20% 25VDC CER	28480	0160-0127
A1C70	0160-4819	7		CAPACITOR-FXD 2200PF +-5% 100VDC CER	28480	0160-4819
A1C71	0160-4805	1	1	CAPACITOR-FXD 47PF +-5% 100VDC CER 0+-30	28480	0160-4805
A1C72	0180-0562	1		CAPACITOR-FXD 33UF+-20% 10VDC TA	56289	196D336X0010KA1
A1C73				NOT ASSIGNED		
A1C74				NOT ASSIGNED		
A1C75	0160-0576	5		CAPACITOR-FXD .1UF +-20% 50VDC CER	28480	0160-0576
A1C76	0160-4040	6		CAPACITOR-FXD 1000PF +-5% 100VDC CER	28480	0160-4040
A1C77	0160-4040	6		CAPACITOR-FXD 1000PF +-5% 100VDC CER	28480	0160-4040
A1C78	0160-4040	6		CAPACITOR-FXD 1000PF +-5% 100VDC CER	28480	0160-4040
A1C79	0160-4040	6		CAPACITOR-FXD 1000PF +-5% 100VDC CER	28480	0160-4040
A1C80				NOT ASSIGNED		
A1C81	0160-4040	6		CAPACITOR-FXD 1000PF +-5% 100VDC CER	28480	0160-4040
A1C82	0160-4040	6		CAPACITOR-FXD 1000PF +-5% 100VDC CER	28480	0160-4040
A1C83	0160-4846	0	2	CAPACITOR-FXD 1500PF +-5% 100VDC CER	28480	0160-4846
A1C84	0160-4846	0		CAPACITOR-FXD 1500PF +-5% 100VDC CER	28480	0160-4846
A1C85	0160-0576	5		CAPACITOR-FXD .1UF +-20% 50VDC CER	28480	0160-0576
A1CR1	1901-0050	3	13	DIODE-SWITCHING 80V 200MA 2NS DO-35	28480	1901-0050
A1CR2	1901-0376	6	2	DIODE-GEN PRP 35V 50MA DO-35	28480	1901-0376
A1CR3	1901-0376	6		DIODE-GEN PRP 35V 50MA DO-35	28480	1901-0376
A1CR4	1901-0639	4	4	DIODE-PIN	28480	5082-3080
A1CR5	1901-0639	4		DIODE-PIN	28480	5082-3080
A1CR6	1901-0639	4		DIODE-PIN	28480	5082-3080
A1CR7	1901-0639	4		DIODE-PIN	28480	5082-3080
A1CR8	1906-0096	7	1	DIODE-FW BRDG 200V 2A	04713	MDA202
A1CR9	1884-0221	2	1	THYRISTOR-SCR VRRM=300	04713	MCR106-5
A1CR10	1902-3234	3	1	DIODE-ZNR 19.6V 5% DO-35 PD=.4W	28480	1902-3234
A1CR11	1901-0050	3		DIODE-SWITCHING 80V 200MA 2NS DO-35	28480	1901-0050
A1CR12	1901-0782	8	2	DIODE-SCHOTTKY 1N5821 30V 3A	04713	1N5821
A1CR13	1902-3110	4	1	DIODE-ZNR 5.9V 2% DO-35 PD=.4W TC=+.017%	28480	1902-3110
A1CR14	1901-0782	8		DIODE-SCHOTTKY 1N5821 30V 3A	04713	1N5821
A1CR15	1901-0050	3		DIODE-SWITCHING 80V 200MA 2NS DO-35	28480	1901-0050
A1CR16	1901-0050	3		DIODE-SWITCHING 80V 200MA 2NS DO-35	28480	1901-0050
A1CR17	1901-0050	3		DIODE-SWITCHING 80V 200MA 2NS DO-35	28480	1901-0050
A1CR18	1901-0050	3		DIODE-SWITCHING 80V 200MA 2NS DO-35	28480	1901-0050
A1CR19	1901-0050	3		DIODE-SWITCHING 80V 200MA 2NS DO-35	28480	1901-0050
A1CR20	1901-0050	3		DIODE-SWITCHING 80V 200MA 2NS DO-35	28480	1901-0050
A1CR21	1901-0050	3		DIODE-SWITCHING 80V 200MA 2NS DO-35	28480	1901-0050
A1CR22	1901-0050	3		DIODE-SWITCHING 80V 200MA 2NS DO-35	28480	1901-0050
A1CR23	1901-0050	3		DIODE-SWITCHING 80V 200MA 2NS DO-35	28480	1901-0050
A1CR24	1901-0179	7	2	DIODE-SWITCHING 15V 50MA 750PS DO-7	28480	1901-0179
A1CR25	1901-0179	7		DIODE-SWITCHING 15V 50MA 750PS DO-7	28480	1901-0179
A1CR26	1901-1068	5	2	DIODE-SM SIG SCHOTTKY	28480	1901-1068
A1CR27	1901-0050	3		DIODE-SWITCHING 80V 200MA 2NS DO-35	28480	1901-0050
A1CR28	1901-0050	3		DIODE-SWITCHING 80V 200MA 2NS DO-35	28480	1901-0050
A1CR29	1901-1068	5		DIODE-SM SIG SCHOTTKY	28480	1901-1068
A1CR30	1902-0126	6	1	DIODE-ZNR 2.61V 5% DO-7 PD=.4W TC=-.072%	28480	1902-0126
A1E1	9170-0029	3	1	CORE-SHIELDING BEAD	28480	9170-0029
A1F1	2110-0201	0	1	FUSE .25A 250V TD 1.25X.25 UL	28480	2110-0201
A1F1	2110-0565	9	1	FUSEHOLDER CAP 12A MAX FOR UL	28480	2110-0565
A1F2	2110-0002	9	1	FUSE 2A 250V NTD 1.25X.25 UL	75915	312002
A1J1	1250-1782	9	1	CONNECTOR-RF BNC FEM PCH-PNL 50-OHM	28480	1250-1782
A1J2	1250-1824	0	1	BNC FUSED PC MU	28480	1250-1824
A1J3	1251-4743	0	1	CONNECTOR-AC PUR HP-9 MALE REC-FLG THRMP	28480	1251-4743
A1J4	1251-8261	5	1	JACK POWER PCB MT	28480	1251-8261
A1J5	1250-1842	2	1	BNC RTANG PC MNT	28480	1250-1842

See introduction to this section for ordering information
*Indicates factory selected value

HP 5384A and HP 5385A
Replaceable Parts

Table 6-10. HP 5385A With Oven Oscillator Replaceable Parts (Continued)

Reference Designation	HP Part Number	C D	Qty	Description	Mfr Code	Mfr Part Number
A1J6	1251-8304	7	1	CONN-POST TYPE .100-PIN-SPCG 8-CONT	28480	1251-8304
A1J7				NOT ASSIGNED		
A1J8	1251-7684	4	1	CABLE ASSY 14 POST	28480	1251-7684
A1J9	1251-8139	6	1	CONN-POST TYPE .100-PIN-SPCG 14-CONT	28480	1251-8139
A1K1	0490-1317	3	1	RELAY-REED 1C 250MA 200VDC 5VDC-COIL 3VA	28480	0490-1317
A1L1	9140-0718	4	1	INDUCTOR-FIXED NORM IND: 230UH à 1.5ADC	28480	9140-0718
A1L2	9100-1788	6	10	CORE-FERRITE CHOKE-WIDEBAND; IMP:>680	28480	9100-1788
A1L3	9140-0531	9	2	INDUCTOR RF-CH-MLD 1UH 5% .105DX.26LG	28480	9140-0531
A1L4	9100-2562	6	1	INDUCTOR RF-CH-MLD 100UH 10%	28480	9100-2562
A1L5	9100-1788	6		CORE-FERRITE CHOKE-WIDEBAND; IMP:>680	28480	9100-1788
A1L6	9100-1788	6		CORE-FERRITE CHOKE-WIDEBAND; IMP:>680	28480	9100-1788
A1L7	9100-1788	6		CORE-FERRITE CHOKE-WIDEBAND; IMP:>680	28480	9100-1788
A1L8				NOT ASSIGNED		
A1L9	9100-1788	6		CORE-FERRITE CHOKE-WIDEBAND; IMP:>680	28480	9100-1788
A1L10	9100-2817	4	2	INDUCTOR RF-CH-MLD 100NH 5% .105DX.26LG	28480	9100-2817
A1L11	9100-1788	6		CORE-FERRITE CHOKE-WIDEBAND; IMP:>680	28480	9100-1788
A1L12	9100-2817	4		INDUCTOR RF-CH-MLD 100NH 5% .105DX.26LG	28480	9100-2817
A1L13	9100-1788	6		CORE-FERRITE CHOKE-WIDEBAND; IMP:>680	28480	9100-1788
A1L14	9140-0521	7	1	INDUCTOR RF-CH-MLD 300NH 5% .105DX.26LG	28480	9140-0521
A1L15	9140-0310	2	1	INDUCTOR RF-CH-MLD 390NH 5% .105DX.26LG	28480	9140-0310
A1L16	9100-1788	6		CORE-FERRITE CHOKE-WIDEBAND; IMP:>680	28480	9100-1788
A1L17	9100-1788	6		CORE-FERRITE CHOKE-WIDEBAND; IMP:>680	28480	9100-1788
A1L18	9100-1788	6		CORE-FERRITE CHOKE-WIDEBAND; IMP:>680	28480	9100-1788
A1L19	9140-0531	9		INDUCTOR RF-CH-MLD 1UH 5% .105DX.26LG	28480	9140-0531
A1Q1	1854-0215	1	2	TRANSISTOR NPN SI PD=350MW FT=300MHZ	04713	2N3904
A1Q2	1855-0327	8	1	TRANSISTOR J-FET 2N4416 N-CHAN D-MODE	01295	2N4416
A1Q3	1853-0354	7	1	TRANSISTOR PNP SI TO-92 PD=350MW	28480	1853-0354
A1Q4	1855-0414	4	1	TRANSISTOR J-FET 2N4393 N-CHAN D-MODE	04713	2N4393
A1Q5	1854-0215	1		TRANSISTOR NPN SI PD=350MW FT=300MHZ	04713	2N3904
A1Q6				NOT ASSIGNED		
A1Q7				NOT ASSIGNED		
A1Q8	1853-0015	7	2	TRANSISTOR PNP SI PD=200MW FT=500MHZ	28480	1853-0015
A1Q9	1853-0015	7		TRANSISTOR PNP SI PD=200MW FT=500MHZ	28480	1853-0015
A1Q10	1853-0363	8	1	TRANSISTOR PNP SI PD=50W FT=20MHZ	03508	X45H281
A1Q11	1854-0013	7	1	TRANSISTOR NPN 2N2218A SI TO-5 PD=800MW	04713	2N2218A
A1Q12	1854-0477	7	1	TRANSISTOR NPN 2N2222A SI TO-18 PD=500MW	04713	2N2222A
A1R1	0698-8827	4	4	RESISTOR 1M 1% .125W F TC=0+-100	28480	0698-8827
A1R2	0757-0706	8	1	RESISTOR 51.1 1% .25W F TC=0+-100	24546	C5-1/4-T0-51R1-F
A1R3	0698-8827	4		RESISTOR 1M 1% .125W F TC=0+-100	28480	0698-8827
A1R4	0699-0071	6	2	RESISTOR 4.64M 1% .125W F TC=0+-100	28480	0699-0071
A1R5	0698-7276	5	1	RESISTOR 46.4K 1% .05W F TC=0+-100	24546	C3-1/8-T0-4642-F
A1R6	0757-0346	2	2	RESISTOR 10 1% .125W F TC=0+-100	24546	C4-1/8-T0-10R0-F
A1R7	0757-0421	4	4	RESISTOR 825 1% .125W F TC=0+-100	24546	C4-1/8-T0-825R-F
A1R8	0698-3445	2	2	RESISTOR 348 1% .125W F TC=0+-100	24546	C4-1/8-T0-348R-F
A1R9	0698-7236	7	1	RESISTOR 1K 1% .05W F TC=0+-100	24546	C3-1/8-T0-1001-F
A1R10	0698-7233	4	1	RESISTOR 750 1% .05W F TC=0+-100	24546	C3-1/8-T0-750R-F
A1R11	0698-7283	4	1	RESISTOR 90.9K 1% .05W F TC=0+-100	24546	C3-1/8-T0-9092-F
A1R12	0698-8812	7	1	RESISTOR 1 1% .125W F TC=0+-100	28480	0698-8812
A1R13	0698-3136	8	1	RESISTOR 17.8K 1% .125W F TC=0+-100	24546	C4-1/8-T0-1782-F
A1R14	0698-7244	7	1	RESISTOR 2.15K 1% .05W F TC=0+-100	24546	C3-1/8-T0-2151-F
A1R15	0698-3447	4	2	RESISTOR 422 1% .125W F TC=0+-100	24546	C4-1/8-T0-422R-F
A1R16	0698-3447	4		RESISTOR 422 1% .125W F TC=0+-100	24546	C4-1/8-T0-422R-F
A1R17	1810-0541	4	1	NETWORK-RES 6-SIP MULTI-VALUE	28480	1810-0541
A1R18	1810-0219	3	1	NETWORK-RES 8-SIP220.0 OHM X 4	01121	208B221
A1R19	0698-7220	9	2	RESISTOR 215 1% .05W F TC=0+-100	24546	C3-1/8-T0-215R-F
A1R20	0698-7220	9		RESISTOR 215 1% .05W F TC=0+-100	24546	C3-1/8-T0-215R-F
A1R21	0698-7249	2	2	RESISTOR 3.48K 1% .05W F TC=0+-100	24546	C3-1/8-T0-3481-F
A1R22	0698-0084	9	1	RESISTOR 2.15K 1% .125W F TC=0+-100	24546	C4-1/8-T0-2151-F
A1R23	0757-0394	0	3	RESISTOR 51.1 1% .125W F TC=0+-100	24546	C4-1/8-T0-51R1-F
A1R24	0757-0394	0		RESISTOR 51.1 1% .125W F TC=0+-100	24546	C4-1/8-T0-51R1-F
A1R25	0698-3132	4	4	RESISTOR 261 1% .125W F TC=0+-100	24546	C4-1/8-T0-2610-F
A1R26	0757-0416	7	6	RESISTOR 511 1% .125W F TC=0+-100	24546	C4-1/8-T0-511R-F
A1R27	0757-0416	7		RESISTOR 511 1% .125W F TC=0+-100	24546	C4-1/8-T0-511R-F
A1R28	0698-3439	4	3	RESISTOR 178 1% .125W F TC=0+-100	24546	C4-1/8-T0-178R-F
A1R29	0698-8957	1	1	RESISTOR 500K 1% .125W F TC=0+-100	28480	0698-8957
A1R30	0698-3439	4		RESISTOR 178 1% .125W F TC=0+-100	24546	C4-1/8-T0-178R-F

See introduction to this section for ordering information
*Indicates factory selected value

Table 6-10. HP 5385A With Oven Oscillator Replaceable Parts (Continued)

Reference Designation	HP Part Number	C	D	Qty	Description	Mfr Code	Mfr Part Number
A1R31	0698-8827	4			RESISTOR 1M 1% .125W F TC=0+-100	28480	0698-8827
A1R32	0757-0442	9		5	RESISTOR 10K 1% .125W F TC=0+-100	24546	C4-1/8-T0-1002-F
A1R33	0757-0442	9			RESISTOR 10K 1% .125W F TC=0+-100	24546	C4-1/8-T0-1002-F
A1R34	2100-1788	9		1	RESISTOR-TRMR 500 10% C TOP-ADJ 1-TRN	73138	82PRS00
A1R35	0757-0280	3		3	RESISTOR 1K 1% .125W F TC=0+-100	24546	C4-1/8-T0-1001-F
A1R36	0698-3439	4			RESISTOR 178 1% .125W F TC=0+-100	24546	C4-1/8-T0-178R-F
A1R37	0698-3155	1		1	RESISTOR 4.64K 1% .125W F TC=0+-100	24546	C4-1/8-T0-4641-F
A1R38	0757-0421	4			RESISTOR 825 1% .125W F TC=0+-100	24546	C4-1/8-T0-825R-F
A1R39	0757-0442	9			RESISTOR 10K 1% .125W F TC=0+-100	24546	C4-1/8-T0-1002-F
A1R40	0757-0442	9			RESISTOR 10K 1% .125W F TC=0+-100	24546	C4-1/8-T0-1002-F
A1R41	0698-3156	2		2	RESISTOR 14.7K 1% .125W F TC=0+-100	24546	C4-1/8-T0-1472-F
A1R42	0698-8827	4			RESISTOR 1M 1% .125W F TC=0+-100	28480	0698-8827
A1R43	2100-0558	9		1	RESISTOR-TRMR 20K 10% C TOP-ADJ 1-TRN	28480	2100-0558
A1R44	0757-0199	3		1	RESISTOR 21.5K 1% .125W F TC=0+-100	24546	C4-1/8-T0-2152-F
A1R45- A1R48					NOT ASSIGNED		
A1R49	1810-0488	8		1	NETWORK-RES 8-SIP4.7K OHM X 4	28480	1810-0488
A1R50	0812-0021	8		1	RESISTOR .47 5% 3W PW TC=0+-90	91637	CU2B1-3-T2-47/100-J
A1R51					NOT ASSIGNED		
A1R52	0757-0394	0			RESISTOR 51.1 1% .125W F TC=0+-100	24546	C4-1/8-T0-51R1-F
A1R53	0698-3132	4			RESISTOR 261 1% .125W F TC=0+-100	24546	C4-1/8-T0-2610-F
A1R54	0757-1093	8		2	RESISTOR 3K 1% .125W F TC=0+-100	24546	C4-1/8-T0-3001-F
A1R55	0757-0465	6		2	RESISTOR 100K 1% .125W F TC=0+-100	24546	C4-1/8-T0-1003-F
A1R56	0757-0407	6		1	RESISTOR 200 1% .125W F TC=0+-100	24546	C4-1/8-T0-201-F
A1R57	0757-0289	2		1	RESISTOR 13.3K 1% .125W F TC=0+-100	19701	MF4C1/8-T0-1332-F
A1R58	0757-0399	5		1	RESISTOR 82.5 1% .125W F TC=0+-100	24546	C4-1/8-T0-82R5-F
A1R59	0757-0416	7			RESISTOR 511 1% .125W F TC=0+-100	24546	C4-1/8-T0-511R-F
A1R60	0757-0346	2			RESISTOR 10 1% .125W F TC=0+-100	24546	C4-1/8-T0-10R0-F
A1R61	0698-3398	4		1	RESISTOR 46.4 1% .5W F TC=0+-100	28480	0698-3398
A1R62	0757-0200	7		2	RESISTOR 5.62K 1% .125W F TC=0+-100	24546	C4-1/8-T0-5621-F
A1R63	0757-0200	7			RESISTOR 5.62K 1% .125W F TC=0+-100	24546	C4-1/8-T0-5621-F
A1R64	0699-0071	6			RESISTOR 4.64M 1% .125W F TC=0+-100	28480	0699-0071
A1R65	1810-0370	7		1	NETWORK-RES 8-SIP220.0 OHM X 7	01121	208A221
A1R66	0686-7505	8		1	RESISTOR 75 5% .5W CC TC=0+412	01121	EB7505
A1R67	0757-0442	9			RESISTOR 10K 1% .125W F TC=0+-100	24546	C4-1/8-T0-1002-F
A1R68	0757-0405	4		2	RESISTOR 162 1% .125W F TC=0+-100	24546	C4-1/8-T0-162R-F
A1R69	0757-0405	4			RESISTOR 162 1% .125W F TC=0+-100	24546	C4-1/8-T0-162R-F
A1R70	0698-7212	9		2	RESISTOR 100 1% .05W F TC=0+-100	24546	C3-1/8-T0-100R-F
A1R71	0698-7212	9			RESISTOR 100 1% .05W F TC=0+-100	24546	C3-1/8-T0-100R-F
A1R72	0698-3156	2			RESISTOR 14.7K 1% .125W F TC=0+-100	24546	C4-1/8-T0-1472-F
A1R73	0698-7197	9		1	RESISTOR 23.7 1% .05W F TC=0+-100	24546	C3-1/8-T0-23R7-F
A1R74	0698-7219	6		1	RESISTOR 196 1% .05W F TC=0+-100	24546	C3-1/8-T0-196R-F
A1R75	0757-0420	3		2	RESISTOR 750 1% .125W F TC=0+-100	24546	C4-1/8-T0-751-F
A1R76	0757-0419	0		1	RESISTOR 681 1% .125W F TC=0+-100	24546	C4-1/8-T0-681R-F
A1R77	2100-0554	5		1	RESISTOR-TRMR 500 10% C TOP-ADJ 1-TRN	28480	2100-0554
A1R78	0757-0465	6			RESISTOR 100K 1% .125W F TC=0+-100	24546	C4-1/8-T0-1003-F
A1R79	0757-0420	3			RESISTOR 750 1% .125W F TC=0+-100	24546	C4-1/8-T0-751-F
A1R80	0698-0082	7		5	RESISTOR 464 1% .125W F TC=0+-100	24546	C4-1/8-T0-4640-F
A1R81	0698-0082	7			RESISTOR 464 1% .125W F TC=0+-100	24546	C4-1/8-T0-4640-F
A1R82	0757-0283	6		2	RESISTOR 2K 1% .125W F TC=0+-100	24546	C4-1/8-T0-2001-F
A1R83	0757-1093	8			RESISTOR 3K 1% .125W F TC=0+-100	24546	C4-1/8-T0-3001-F
A1R84	0698-0082	7			RESISTOR 464 1% .125W F TC=0+-100	24546	C4-1/8-T0-4640-F
A1R85	0698-0082	7			RESISTOR 464 1% .125W F TC=0+-100	24546	C4-1/8-T0-4640-F
A1R86	0698-3445	2			RESISTOR 348 1% .125W F TC=0+-100	24546	C4-1/8-T0-348R-F
A1R87	0757-0421	4			RESISTOR 825 1% .125W F TC=0+-100	24546	C4-1/8-T0-825R-F
A1R88	0757-0421	4			RESISTOR 825 1% .125W F TC=0+-100	24546	C4-1/8-T0-825R-F
A1R89	0698-3460	1		1	RESISTOR 422K 1% .125W F TC=0+-100	28480	0698-3460
A1R90	0757-0416	7			RESISTOR 511 1% .125W F TC=0+-100	24546	C4-1/8-T0-511R-F
A1R91	0698-3132	4			RESISTOR 261 1% .125W F TC=0+-100	24546	C4-1/8-T0-2610-F
A1R92	0698-3132	4			RESISTOR 261 1% .125W F TC=0+-100	24546	C4-1/8-T0-2610-F
A1R93	0757-0280	3			RESISTOR 1K 1% .125W F TC=0+-100	24546	C4-1/8-T0-1001-F
A1R94	0698-7229	8		1	RESISTOR 511 1% .05W F TC=0+-100	24546	C3-1/8-T0-511R-F
A1R95	0757-0416	7			RESISTOR 511 1% .125W F TC=0+-100	24546	C4-1/8-T0-511R-F
A1R96	0698-7249	2			RESISTOR 3.48K 1% .05W F TC=0+-100	24546	C3-1/8-T0-3481-F
A1R97	0698-5808	5		1	RESISTOR 4K 1% .125W F TC=0+-100	24546	C4-1/8-T0-4001-F
A1R98- A1R101					NOT ASSIGNED		

See introduction to this section for ordering information
*Indicates factory selected value

HP 5384A and HP 5385A
Replaceable Parts

Table 6-10. HP 5385A With Oven Oscillator Replaceable Parts (Continued)

Reference Designation	HP Part Number	C D	Qty	Description	Mfr Code	Mfr Part Number
A1R102	0757-0280	3		RESISTOR 1K 1% .125W F TC=0+-100	24546	C4-1/8-T0-1001-F
A1R103	0757-0416	7		RESISTOR 511 1% .125W F TC=0+-100	24546	C4-1/8-T0-511R-F
A1R104	0698-3152	8	1	RESISTOR 3.48K 1% .125W F TC=0+-100	24546	C4-1/8-T0-3481-F
A1R105	0757-0283	6		RESISTOR 2K 1% .125W F TC=0+-100	24546	C4-1/8-T0-2001-F
A1R106	0837-0220	1	1	THERMISTOR ROD 10K-0HM TC=-3.83%/C-DEG	28480	0837-0220
A1R107	1810-0368	3	1	NETWORK-RES 6-SIP10.0K OHM X 5	01121	206A103
A1R108	0698-0082	7		RESISTOR 464 1% .125W F TC=0+-100	24546	C4-1/8-T0-4640-F
A1R109	0757-0401	0	1	RESISTOR 100 1% .125W F TC=0+-100	24546	C4-1/8-T0-101-F
A1S1	3101-2656	5	1	SS LIN SEL 90PC	28480	3101-2656
A1S2	3101-2644	1	1	SWITCH-PB DPDT ALTN .5A 100VAC	28480	3101-2644
A1S3	3101-2453	0	1	SWITCH-TGL SUBMIN DPDT .02A 20VAC/DC PC	28480	3101-2453
A1T1	9100-2684	3	1	TRANSFORMER-POWER 115/230; 48/60 HZ	28480	9100-2684
A1TP1	1251-0600	0	13	CONNECTOR-SGL CONT PIN 1.14-MM-BSC-SZ SQ	28480	1251-0600
A1TP2	1251-0600	0		CONNECTOR-SGL CONT PIN 1.14-MM-BSC-SZ SQ	28480	1251-0600
A1TP3	1251-0600	0		CONNECTOR-SGL CONT PIN 1.14-MM-BSC-SZ SQ	28480	1251-0600
A1TP4	1251-0600	0		CONNECTOR-SGL CONT PIN 1.14-MM-BSC-SZ SQ	28480	1251-0600
A1TP5	1251-0600	0		CONNECTOR-SGL CONT PIN 1.14-MM-BSC-SZ SQ	28480	1251-0600
A1TP6	1251-0600	0		CONNECTOR-SGL CONT PIN 1.14-MM-BSC-SZ SQ	28480	1251-0600
A1TP7	1251-0600	0		CONNECTOR-SGL CONT PIN 1.14-MM-BSC-SZ SQ	28480	1251-0600
A1TP8	1251-0600	0		CONNECTOR-SGL CONT PIN 1.14-MM-BSC-SZ SQ	28480	1251-0600
A1TP9	1251-0600	0		CONNECTOR-SGL CONT PIN 1.14-MM-BSC-SZ SQ	28480	1251-0600
A1TP10	1251-0600	0		CONNECTOR-SGL CONT PIN 1.14-MM-BSC-SZ SQ	28480	1251-0600
A1TP11	1251-0600	0		CONNECTOR-SGL CONT PIN 1.14-MM-BSC-SZ SQ	28480	1251-0600
A1TP12	1251-0600	0		CONNECTOR-SGL CONT PIN 1.14-MM-BSC-SZ SQ	28480	1251-0600
A1TP13	1251-0600	0		CONNECTOR-SGL CONT PIN 1.14-MM-BSC-SZ SQ	28480	1251-0600
A1U1*				IC MUL REG CTR		
A1U3	1820-3075	6	1	IC RCVR ECL/10KH LINE RCVR TPL	28480	1820-3075
A1U4	1813-0217	7	3	IC WIDEBAND AMPL T0-39 PKG	04713	MWA310
A1U5	1813-0217	7		IC WIDEBAND AMPL T0-39 PKG	04713	MWA310
A1U6	1858-0040	8	1	TRANSISTOR ARRAY 16-PIN PLSTC DIP	3L585	CA3127E
A1U7	1826-0904	6	1	IC-LM330T-5.0	28480	1826-0904
A1U8	1826-0544	0	1	IC V RGLTR-V-REF-FXD 2.5V 8-DIP-C PKG	28480	1826-0544
A1U9	1826-0428	9	1	IC 3S24 MODULATOR 16-DIP-C	01295	SG3524J
A1U10	1826-0393	7	1	IC V RGLTR-ADJ-POS 1.2/37V T0-220 PKG	28480	1826-0393
A1U11	1858-0054	4	1	TRANSISTOR ARRAY 16-PIN PLSTC DIP	28480	1858-0054
A1U12	1826-0065	0	1	IC COMPARATOR PRON 8-DIP-P PKG	S0545	UPC311C
A1U13	1820-1425	6	1	IC SCHMITT-TRIG TTL LS NAND QUAD 2-INP	01295	SN74LS132N
A1U14	1820-2096	9	1	IC CNTR TTL LS BIN DUAL 4-BIT	01295	SN74LS393N
A1U15	1820-1975	1	1	IC SHF-RGTR TTL LS NEG-EDGE-TRIG PRL-IN	01295	SN74LS165N
A1U16	1813-0217	7		IC WIDEBAND AMPL T0-39 PKG	04713	MWA310
A1U17	1826-0501	9	1	IC MULTIPLXR 2-CHAN-ANLG TRIPLE 16-DIP-P	04713	MC14053BCP
A1U18	1826-0161	7	1	IC OP AMP GP QUAD 14-DIP-P PKG	04713	MLM324P
A1U19	1820-2904	8	1	IC PRESOR ECL	28480	1820-2904
A1W1	8120-4168	3	1	FLAT RIBBON ASSY 8-COND 2.5-IN-LG	28480	8120-4168
A1XF1	2110-0269	0	1	FUSEHOLDER-CLIP TYPE .25D-FUSE	28480	2110-0269
A1XF2	2110-0642	3	1	FUSEHOLDER-EXTR POST 6.3A 250V BAY CAP	28480	2110-0642
A1XU1	1200-0654	7	2	SOCKET-IC 40-CONT DIP DIP-SLDR	28480	1200-0654
A1XU2	1200-0654	7		SOCKET-IC 40-CONT DIP DIP-SLDR	28480	1200-0654
A1XW1	1200-0473	8	1	SOCKET-IC 16-CONT DIP DIP-SLDR	28480	1200-0473
A1Y1A	0960-0636	4	1	OVEN-OSCILLATOR MODULE FREQ: 10 MHZ	28480	0960-0636
W1	8120-1378	1	1	CABLE ASSY 18AWG 3-CNDCT JGK-JKT	28480	8120-1378
W3	8150-0450	1	1	WIRE 24AWG 0 300V PVC 7X32 80C	28480	8150-0450
W4	8150-0449	8	1	WIRE 24AWG R 300V PVC 7X32 80C	28480	8150-0449
W5	8150-0448	7	1	WIRE 24AWG BR 300V PVC 7X32 80C	28480	8150-0448
W6	8150-2846	3	1	WIRE 18AWG G/Y 300V PVC 19X30 10SC	28480	8150-2846

See introduction to this section for ordering information
*Indicates factory selected value

Table 6-11. Code List of Manufacturers

Mfr Code	Manufacturer Name	Address	Zip Code
50545	NIPPON ELECTRIC CO	TOKYO	JP
00000	ANY SATISFACTORY SUPPLIER		
01121	ALLEN-BRADLEY CO	MILWAUKEE	WI 53204
01295	TEXAS INSTR INC SEMICOND CMPNT DIV	DALLAS	TX 75222
03508	GE CO SEMICONDUCTOR PROD DEPT	AUBURN	NY 13201
04713	MOTOROLA SEMICONDUCTOR PRODUCTS	PHOENIX	AZ 85008
16299	CORNING GLASS WKS COMPONENT DIV	RALEIGH	NC 27604
19701	MEPCO/ELECTRA CORP	MINERAL WELLS	TX 76067
24546	CORNING GLASS WORKS (BRADFORD)	BRADFORD	PA 16701
28480	HEWLETT-PACKARD CO CORPORATE HQ	PALO ALTO	CA 94304
3L585	RCA CORP SOLID STATE DIV	SOMERVILLE	NJ
51642	CENTRE ENGINEERING INC	STATE COLLEGE	PA 16801
52763	STETTNER ELECTRONICS INC	CHATTANOOGA	TN 13035
56289	SPRAGUE ELECTRIC CO	NORTH ADAMS	MA 01247
73138	BECKMAN INSTRUMENTS INC HELIPOT DIV	FULLERTON	CA 92634
75915	LITTELFUSE INC	DES PLAINES	IL 60016
91637	DALE ELECTRONICS INC	COLUMBUS	NE 68601

HP 5384A and HP 5385A
Replaceable Parts

Table 6-12. HP 5385A Replaceable Mechanical Parts (Continued)

Reference Designation	HP Part Number	C D	Qty	Description	Mfr Code	Mfr Part Number
MECHANICAL PARTS						
A1	SEE TABLES 6-2THRU6-4	1 0		MOTHERBOARD	28480 28480	SEE TABLES 6-2THRU6-4
A2	ORDER THE INDIVIDUAL PARTS; MP10, MP11, MP12 & H17	3 1 0 7 8		DISPLAY ASSEMBLY SEE FIGURE 6-1		
A3	05384-60003	8	1	BATTERY PACK CHARGER BOARD ASSEMBLY	28480	05384-60003
A4	05384-60004	9	1	HP-IL I/O BOARD ASSEMBLY	28480	05384-60004
A5	05384-60005	0	1	HP-IB I/O BOARD ASSEMBLY	28480	05384-60005
H1	3050-0243	3	2	WASHER-FL NM 3/8 IN .385-IN-ID .75-IN-OD	28480	3050-0243
H2	0510-1220	1	2	RETAINER PR-ON STUD	28480	0510-1220
H3	0340-0468	6	1	INSULATOR-XSTR NYLON	28480	0340-0468
H4	0515-0244	7	7	SCREW-MACH M3 X 0.5 4MM-LG PAN-HD	28480	0515-0244
H5	2190-0584	0	8	WASHER-LK HLCL 3.0 MM 3.1-MM-ID	28480	2190-0584
H6	0515-0244	7		SCREW-MACH M3 X 0.5 4MM-LG PAN-HD	28480	0515-0244
H7	2190-0584	0		WASHER-LK HLCL 3.0 MM 3.1-MM-ID	28480	2190-0584
H8A	0380-1332	9	2	STANDOFF-HEX M/F	28480	0380-1332
H8B	0515-0911	5	2	SCREW-MACH M3 X 0.5 6MM-LG PAN-HD	00000	ORDER BY DESCRIPTION
H9	2940-0256	4	1	NUT-HEX-DBL-CHAM 1/2-28-THD .095-IN-THK	28480	2940-0256
H10	2190-0068	5	1	WASHER-LK INTL T 1/2 IN .505-IN-ID	28480	2190-0068
H11	2190-0584	0		WASHER-LK HLCL 3.0 MM 3.1-MM-ID	28480	2190-0584
H12	0515-0244	7		SCREW-MACH M3 X 0.5 4MM-LG PAN-HD	28480	0515-0244
H13				NOT ASSIGNED		
H14	3050-0891	7	2	WASHER-FL MTLCL 3.0 MM 3.3-MM-ID	28480	3050-0891
H15	2190-0644	3	2	INTERNAL STAR WASHER	28480	2190-0644
H16	2260-0001	5	2	NUT-HEX-DBL-CHAM 4-40-THD .094-IN-THK	28480	2260-0001
H17	0624-0333	6	2	SCREW-TPG 4-20 .25-IN-LG PAN-HD-POZI STL	28480	0624-0333
H18	0360-0040	2	1	TERMINAL-SLDR LUG LK-MTG FOR-#1/4-SCR	28480	0360-0040
H19	3050-0893	9	2	WASHER-FL MTLCL 4.0 MM 4.4-MM-ID	28480	3050-0893
H20	2190-0646	5	2	WASHER-LK EXT T-B 4.0 MM 4.15-MM-ID	28480	2190-0646
H21	0535-0006	1	2	NUT-HEX DBL-CHAM M4 X 0.7 3.2MM-THK	00000	ORDER BY DESCRIPTION
H22	2950-0072	3	1	NUT-HEX-DBL-CHAM 1/4-32-THD .062-IN-THK	00000	ORDER BY DESCRIPTION
H23	2190-0060	7	1	WASHER-LK INTL T 1/4 IN .256-IN-ID	28480	2190-0060
H24	0590-1251	6	2	NUT-SPCLY 15/32-32-THD .1-IN-THK .562-WD	00000	ORDER BY DESCRIPTION
H25	3050-0892	8	4	WASHER-FL MTLCL 3.5 MM 3.8-MM-ID	28480	3050-0892
H26	2190-0585	1	4	WASHER-LK HLCL 3.5 MM 3.6-MM-ID	28480	2190-0585
H27	0515-1285	8	4	SCREW-MACH M3.5 X 0.6 35MM-LG PAN-HD	00000	ORDER BY DESCRIPTION
H28	0515-0226	5	3	SCREW-MACH M2.5 X 0.45 6MM-LG PAN-HD	00000	ORDER BY DESCRIPTION
MP1	05384-40001	4	1	TOP SHELL (RFI)	28480	05384-40001
MP2	05384-00006	5	1	BATTERY FRAME	28480	05384-00006
MP3	4177-0236	3	4	CLAMP TUBE HD, DN	28480	4177-0236
MP4	0380-1582	1	1	SPACER-SNAP-IN 1.25 IN LG; .28 IN DIA	28480	0380-1582
MP5	05384-00003	2	1	REAR PANEL	28480	05384-00003
MP6	05384-00007	6	1	BATTERY STOP	28480	05384-00007
MP7	05384-00009	8	1	TOP RF SHIELD	28480	05384-00009
MP8	0370-2862	1	1	PUSHBUTTON 0.230 IN SQ; 0.425 IN HGT	28480	0370-2862
MP9	05384-00005	4	1	BNC SPACER	28480	05384-00005
MP10	05384-60104	0	1	LIQUID CRYSTAL DISPLAY ASSEMBLY	28480	05384-60104
MP11	05384-60102	8	1	KEYBOARD ASSEMBLY	28480	05384-60102
MP12	05040-5448	1	1	LCD WINDOW	28480	05040-5448
MP13	05384-00001	0	1	FRONT PANEL	28480	05384-00001
MP14	0370-1005	2	1	KNOB-BASE-PTR 3/8 JGK .125-IN-ID	28480	0370-1005
MP15	05384-40002	5	1	BOTTOM SHELL (RFI)	28480	05384-40002
MP16	1600-1185	9	2	FASTENER-RACK MOUNT	28480	1600-1185
MP17	5040-7222	3	2	REAR FOOT	28480	5040-7222
MP18	05384-00010	1	1	BOTTOM RF SHIELD	28480	05384-00010
MP19	1460-1345	5	2	TILT STAND SST	28480	1460-1345
MP20	5040-7201	8	2	FRONT FOOT	28480	5040-7201
W2	8120-4167	2	1	CBLY 14 PIN FT 26G	28480	8120-4167

See introduction to this section for ordering information
*Indicates factory selected value

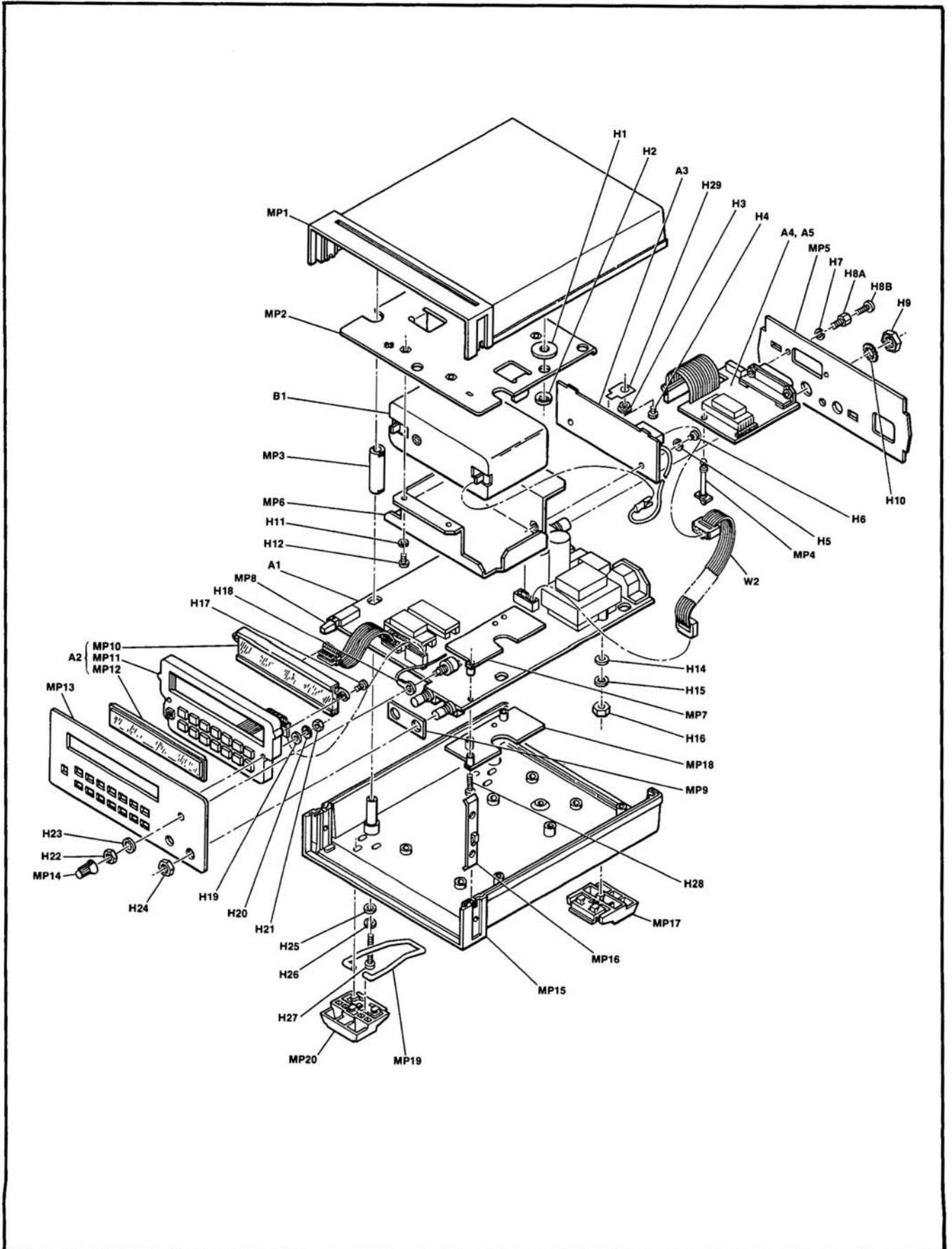

Figure 6-1. HP 5384A Exploded View

HP 5384A and HP 5385A
Replaceable Parts

Table 6-13. HP 5385A Replaceable Mechanical Parts (Continued)

Reference Designation	HP Part Number	C D	Qty	Description	Mfr Code	Mfr Part Number
MECHANICAL PARTS						
A1	SEE TABLES 6-9THRU6-10	1 7		MOTHERBOARD	28480	6-9THRU6-10
A2	ORDER THE INDIVIDUAL PARTS; MP10, MP11, MP12 & H17	3 1 0 7 8		DISPLAY ASSEMBLY SEE FIGURE 6-2		
A3	05384-60003	8	1	BATTERY PACK CHARGER BOARD ASSEMBLY	28480	05384-60003
A4	05384-60004	9	1	HP-IL I/O BOARD ASSEMBLY	28480	05384-60004
A5	05384-60005	0	1	HP-IB I/O BOARD ASSEMBLY	28480	05384-60005
H1	3050-0243	3	2	WASHER-FL NM 3/8 IN .385-IN-ID .75-IN-OD	28480	3050-0243
H2	0510-1220	1	2	RETAINER PR-ON STUD	28480	0510-1220
H3	0340-0468	6	1	INSULATOR-XSTR NYLON	28480	0340-0468
H4	0515-0244	7	7	SCREW-MACH M3 X 0.5 4MM-LG PAN-HD	28480	0515-0244
H5	2190-0584	0	8	WASHER-LK HLCL 3.0 MM 3.1-MM-ID	28480	2190-0584
H6	0515-0244	7		SCREW-MACH M3 X 0.5 4MM-LG PAN-HD	28480	0515-0244
H7	2190-0584	0		WASHER-LK HLCL 3.0 MM 3.1-MM-ID	28480	2190-0584
H8A	0380-1332	9	2	STANDOFF-HEX M/F	28480	0380-1332
H8B	0515-0911	5	2	SCREW-MACH M3 X 0.5 12MM-LG PAN-HD	00000	ORDER BY DESCRIPTION
H9	2940-0256	4	1	NUT-HEX-DBL-CHAM 1/2-28-THD .095-IN-THK	28480	2940-0256
H10	2190-0068	5	1	WASHER-LK INTL T 1/2 IN .505-IN-ID	28480	2190-0068
H11	2190-0584	0		WASHER-LK HLCL 3.0 MM 3.1-MM-ID	28480	2190-0584
H12	0515-0244	7		SCREW-MACH M3 X 0.5 4MM-LG PAN-HD	28480	0515-0244
H13				NOT ASSIGNED		
H14	3050-0891	7	2	WASHER-FL MTLC 3.0 MM 3.3-MM-ID	28480	3050-0891
H15	2190-0644	3	2	INTERNAL STAR WASHER	28480	2190-0644
H16	2260-0001	5	2	NUT-HEX-DBL-CHAM 4-40-THD .094-IN-THK	28480	2260-0001
H17	0624-0333	6	2	SCREW-TPG 4-20 .25-IN-LG PAN-HD-POZI STL	28480	0624-0333
H18	0360-0040	2	1	TERMINAL-SLDR LUG LK-MTG FOR-#1/4-SCR	28480	0360-0040
H19	3050-0893	9	2	WASHER-FL MTLC 4.0 MM 4.4-MM-ID	28480	3050-0893
H20	2190-0646	5	2	WASHER-LK EXT T-B 4.0 MM 4.15-MM-ID	28480	2190-0646
H21	0535-0006	1	2	NUT-HEX DBL-CHAM M4 X 0.7 3.2MM-THK	00000	ORDER BY DESCRIPTION
H22	2950-0072	3	1	NUT-HEX-DBL-CHAM 1/4-32-THD .062-IN-THK	00000	ORDER BY DESCRIPTION
H23	2190-0060	7	1	WASHER-LK INTL T 1/4 IN .256-IN-ID	28480	2190-0060
H24	0590-1251	6	2	NUT-SPCLY 15/32-32-THD .1-IN-THK .562-WD	00000	ORDER BY DESCRIPTION
H25	3050-0892	8	4	WASHER-FL MTLC 3.5 MM 3.8-MM-ID	28480	3050-0892
H26	2190-0585	1	4	WASHER-LK HLCL 3.5 MM 3.6-MM-ID	28480	2190-0585
H27	0515-1285	5	4	SCREW-MACH M3.5 X 0.6 35MM-LG PAN-HD	00000	ORDER BY DESCRIPTION
MP1	05384-40001	4	1	TOP SHELL (RFI)	28480	05384-40001
MP2	05384-00006	5	1	BATTERY FRAME	28480	05384-00006
MP3	4177-0236	3	4	CLAMP TUBE HD, DN	28480	4177-0236
MP4	0380-1582	1	1	SPACER-SNAP-IN 1.25 IN LG; .28 IN DIA	28480	0380-1582
MP5	05384-00003	2	1	REAR PANEL	28480	05384-00003
MP6	05384-00007	6	1	BATTERY STOP	28480	05384-00007
MP7				NOT USED		
MP8	0370-2862	1	1	PUSHBUTTON 0.230 IN SQ; 0.425 IN HGT	28480	0370-2862
MP9	05384-00005	4	1	BNC SPACER	28480	05384-00005
MP10	05384-60104	0	1	LIQUID CRYSTAL DISPLAY ASSEMBLY	28480	05384-60104
MP11	05384-60102	8	1	KEYBOARD ASSEMBLY	28480	05384-60102
MP12	05040-5448	1	1	LCD WINDOW	28480	05040-5448
MP13	05384-00001	0	1	FRONT PANEL	28480	05384-00001
MP14	0370-1005	2	1	KNOB-BASE-PTR 3/8 JGK .125-IN-ID	28480	0370-1005
MP15	05384-40002	5	1	BOTTOM SHELL (RFI)	28480	05384-40002
MP16	1600-1185	9	2	FASTENER-RACK MOUNT	28480	1600-1185
MP17	5040-7222	3	2	REAR FOOT	28480	5040-7222
MP18	05384-00010	1	1	BOTTOM RF SHIELD	28480	05384-00010
MP19	1460-1345	5	2	TILT STAND SST	28480	1460-1345
MP20	5040-7201	8	2	FRONT FOOT	28480	5040-7201
W2	8120-4167	2	1	CBL Y 14 PIN FT 26G	28480	8120-4167

See introduction to this section for ordering information
*Indicates factory selected value

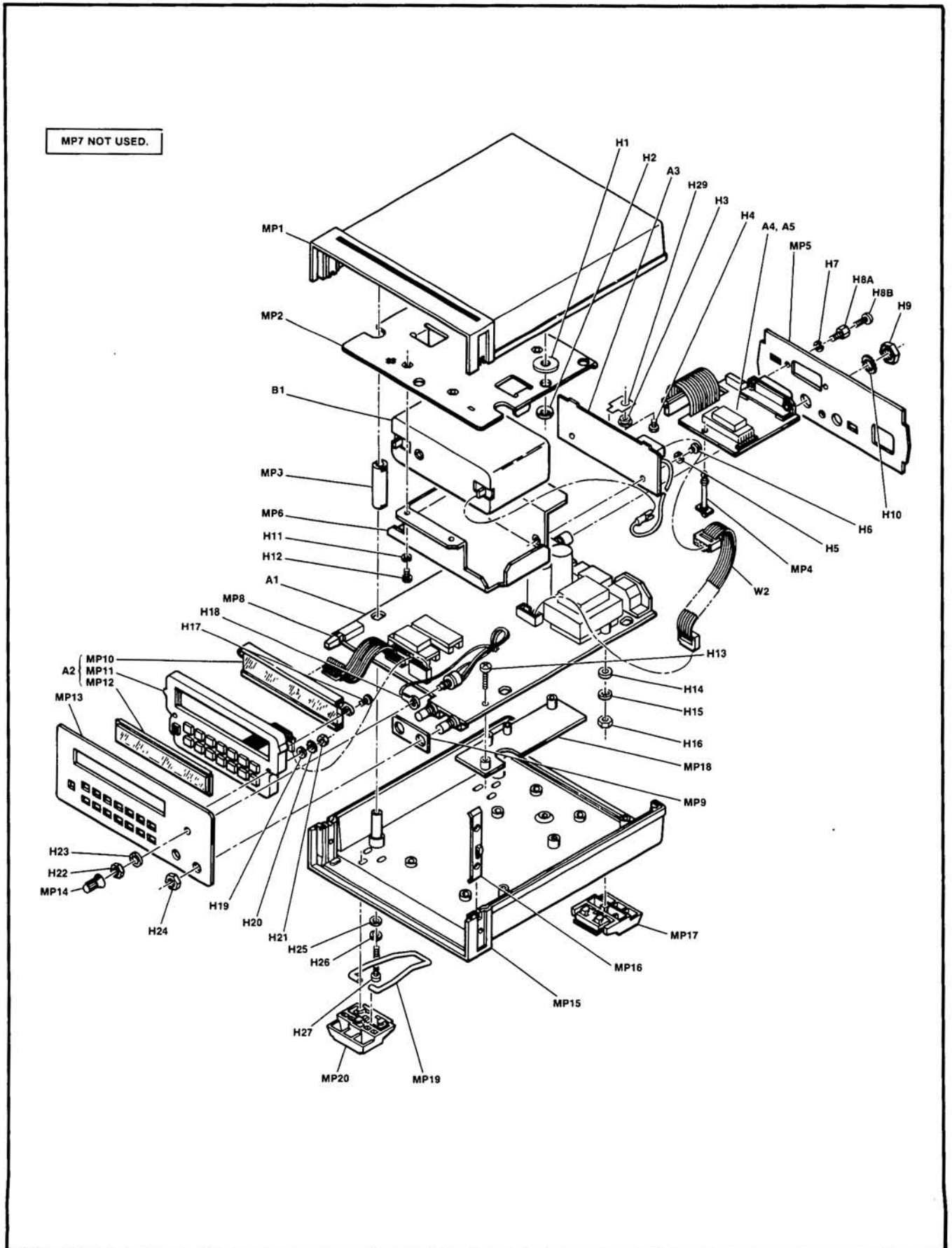

Figure 6-2. HP 5385A Exploded View

SECTION VII MANUAL CHANGES

7-1. INTRODUCTION

7-2. This section contains information adapting this manual with serial prefixes other than that listed on the title page. This manual applies directly to instruments with serial prefix numbers listed on the title page. Refer to Section I for additional important information about serial number coverage.

7-3. MANUAL CHANGES

7-4. As engineering changes are made, newer instruments have serial numbers higher than those listed on the title page of this manual. Instruments having serial prefixes higher than those listed on the title page of this manual are covered in a "Manual Changes" sheet included with this manual. If this change sheet is missing, the information can be supplied by any Hewlett-Packard Sales and Service Office listed at the back of this manual.

7-5. If your instrument's serial number prefix is lower than that listed on the title page of this manual, this manual must be modified to correctly apply to your instrument. To determine which changes must be made to this manual, locate your instrument's serial number prefix in *Table 7-1* and make the indicated changes.

Table 7-1. Manual Backdating

IF INSTRUMENT HAS SERIAL PREFIX	MAKE THE FOLLOWING CHANGES TO MANUAL
2430A	1
2313A for 5384A	1, 2
2312A for 5385A	1, 2

CHANGE 1 (2430A)

Page 6-7, Table 6-2, HP 5384A A1 Motherboard (05384-60001).

Change A1U2 from 1820-3572, masked microprocessor, to A1U2-1, 1818-0762, Piggyback EPROM and A1U2-2, 1820-2650, 38P70 microcomputer. The parts are interchangeable, the masked microprocessor is the preferred part.

Page 6-11, Table 6-3, HP 5384A with TCXO, A1 Motherboard (05384-60006).

Change A1U2 from 1820-3572, masked microprocessor, to A1U2-1, 1818-0762, Piggyback EPROM and A1U2-2,

1820-2650, 38P70 microcomputer. The parts are interchangeable, the masked microprocessor is the preferred part.

Page 6-16, Table 6-4, HP 5384A with Oven Oscillator, A1 Motherboard (05384-60007).

Change A1U2 from 1820-3572, masked microprocessor, to A1U2-1, 1818-0762, Piggyback EPROM and A1U2-2, 1820-2650, 38P70 microcomputer. The parts are interchangeable, the masked microprocessor is the preferred part.

Page 6-21, Table 6-8, HP-IB Board Assembly (05384-60005).

Change A5U5 from 1820-3687, masked microprocessor, to A5U5-1, 1818-0762, Piggyback EPROM and A1U5-2, 1820-2650, 38P70 microcomputer.

Page 6-26, Table 6-9, HP 5385A A1 Motherboard (05385-60001).

Change A1U2 from 1820-3572, masked microprocessor, to A1U2-1, 1818-0762, Piggyback EPROM and A1U2-2, 1820-2650, 38P70 microcomputer. The parts are interchangeable, the masked microprocessor is the preferred part.

Page 6-32, Table 6-10, HP 5385A with Oven Oscillator, A1 Motherboard (05384-60003).

Change A1U2 from 1820-3572, masked microprocessor, to A1U2-1, 1818-0762, Piggyback EPROM and A1U2-2, 1820-2650, 38P70 microcomputer. The parts are interchangeable, the masked microprocessor is the preferred part.

CHANGE 2 (2313A for 5384A, 2312 for 5385A)

Page 6-3, Table 6-2, HP 5384A A1 Motherboard (05384-60001).

Change A1C54 from 0180-0418, 1 uF capacitor to 0180-2698, 4.7 uF, 35 VDC.

Page 6-8, Table 6-3, HP 5384A with TCXO, A1 Motherboard (05384-60006)

Change A1C54 from 0180-0418, 1 uF capacitor to 0180-2698, 4.7 uF, 35 VDC.

Page 6-13, Table 6-4, HP 5384A with Oven Oscillator, A1 Motherboard (05384-60007).

Change A1C54 from 0180-0418, 1 uF capacitor to 0180-2698, 4.7 uF, 35 VDC.

Page 6-17, Table 6-4, HP 5384A with Oven Oscillator, A1 Motherboard (05384-60007)

Add A1W3, 8159-0005, Resistor; zero ohms 22 AWG, then change reference designator to A1M2.

Page 6-22, Table 6-9, HP 5385A A1 Motherboard (05385-60001).

Change A1C54 from 0180-0418, 1uF capacitor to 0180-2698, 4.7 uF, 35 VDC.

HP 5384A and HP 5385A Manual Changes

Page 6-32, Table 6-10, HP 5385A with Oven Oscillator, A1 Motherboard (05385-60003).

Add A1W3, 8159-0005, resistor; zero ohms 22 AWG, then change reference designator to A1M2.

Page 8-47, Figure 8-50, HP 5384A A1 Motherboard Schematic Diagram (sheet 1 of 2).

Change A1C54 to 4.7 μ F.

Add A1W3 from S3 "INT" to "TO BATT B+". Then change reference designator to M2.

Page 8-49, Figure 8-50, HP 5384A A1 Motherboard Schematic Diagram (sheet 2 of 2).

Change A1W2 to M1.

Page 8-51, Figure 8-51, HP 5385A A1 Motherboard Schematic Diagram (sheet 1 of 2).

Change A1C54 to 4.7 μ F.

Add A1W3 from S3 "INT" to "TO BATT B+". then change reference designator to M2.

Page 8-53, Figure 8-51, HP 5385A A1 Motherboard Schematic Diagram (sheet 2 of 2).

Change A1W2 to M1.

SECTION VIII SERVICE

8-1. INTRODUCTION

8-2. This section provides service information and symbol descriptions, component locators, and schematic diagrams. The arrangement of the content of this section is described in detail below. Refer to the Table of Contents for specific page and paragraph numbers.

a. **SCHEMATIC DIAGRAM SYMBOLS AND REFERENCE DESIGNATIONS.** Describes the symbols used on schematic diagrams and reference designators used for parts, subassemblies and assemblies.

b. **IDENTIFICATION MARKINGS.** Describes the method used by Hewlett-Packard for identifying printed circuit boards and assemblies.

c. **SAFETY CONSIDERATIONS.** Describes the safety considerations applicable during maintenance, adjustments, and repair.

d. **SAFETY SYMBOLS.** Lists and describes the safety symbols used on equipment and in manuals.

e. **RECOMMENDED TEST EQUIPMENT.** Refers to test equipment specified in *Table 1-2*.

f. **SERVICE AIDS.** Information provided to assist service personnel.

g. **LOGIC SYMBOLS.** Description of logic symbols used on schematics.

h. **THEORY OF OPERATION.** Presents the theory of operation for the HP 5384A and HP 5385A on two levels.

1. First, the Overall Counter Operation is described using the block diagram. This discussion introduces the major functional circuits and briefly explains their purpose and operation during normal measurements.

2. Second, the Detailed Theory of Operation gives an in-depth explanation of each assembly; its function and operation with respect to measurement cycles. These paragraphs reference the schematic diagrams.

i. **TROUBLESHOOTING.** Provides the troubleshooting information for the HP 5384A and HP 5385A in the following forms:

1. **DIAGNOSTICS,** which are built into the instrument. They serve to verify, by self-check, various functional subsections of the counters' circuitry.

2. **MANUAL TESTS,** which refer to block diagrams, a flowchart and schematics. Schematic diagrams for all assemblies are provided at the end of this section. They are arranged in numerical order according to the assembly number.

8-3. SCHEMATIC DIAGRAM SYMBOLS AND REFERENCE DESIGNATORS

8-4. *Figure 8-1* shows the symbols used on the schematic diagrams. At the bottom of the *Figure 8-1*, the system for reference designators, assemblies, and subassemblies is shown.

8-5. Reference Designations

8-6. Assemblies such as printed circuits are assigned numbers in sequence, A1, A2, etc. As shown in *Figure 8-1*, subassemblies within an assembly are given a subordinate A number. For example, rectifier sub-assembly A1 has the complete designator of A25A1. For individual components, the complete designator is determined by adding the assembly number and subassembly number if any. For example, CR1 on the rectifier assembly is designated A25A1CR1.

8-7. IDENTIFICATION MARKINGS ON PRINTED CIRCUIT BOARDS

8-8. HP printed circuit boards (see *Figure 8-1*) have four identification numbers: an assembly part number, a series number, a revision letter, and a production code.

8-9. The assembly part number has 10 digits (such as 05384-60001) and is the primary identification. All assemblies with the same part number are interchangeable. When a production change is made on an assembly that makes it incompatible with previous assemblies, a change in part number is required. The series number (such as 2312A) is used to document minor electrical changes. As changes are made, the series number is incremented. When replacement boards are ordered, you may receive a replacement with a different series number. If there is a difference between the series number marked on the board and the schematic in this manual, a minor electrical difference exists. If the number on the printed circuit board is lower than that on the schematic, refer to Section VII for backdating information. If it is higher, refer to the looseleaf manual change sheets for this

manual. If the manual change sheets are missing, contact your local Hewlett-Packard Sales and Support Office. See the listing on the back cover of this manual.

8-10. Revision letters (A, B, etc.) denote changes in printed circuit layout. For example, if a capacitor type is changed (electrical value may remain the same) and requires different spacing for its leads, the printed circuit board layout is changed and the revision letter is incremented to the next letter. When a revision letter changes the series number is also usually changed. The production code is the four-digit seven-segment number used for production purposes.

8-11. SAFETY CONSIDERATIONS

8-12. Although this instrument has been designed in accordance with international safety standards, this manual contains information, cautions, and warnings which must be followed to ensure safe operation and to retain the instrument in safe condition. Service and adjustments should be performed only by service-trained personnel.

WARNING

ALL PROTECTIVE EARTH TERMINALS, EXTENSION CORDS, AUTOTRANSFORMERS AND DEVICES CONNECTED TO THE INSTRUMENT SHOULD BE CONNECTED TO A PROTECTIVE EARTH GROUNDED SOCKET. ANY INTERRUPTION OF THE PROTECTIVE EARTH GROUNDING WILL CAUSE A POTENTIAL SHOCK HAZARD THAT COULD RESULT IN PERSONAL INJURY.

ONLY THE 250V FUSES WITH THE REQUIRED RATED CURRENT AND SPECIFIED TYPE SHOULD BE USED. DO NOT USE REPAIRED FUSES OR SHORT CIRCUITED FUSEHOLDERS. TO DO SO COULD CAUSE A SHOCK OR FIRE HAZARD.

8-13. Any adjustments, maintenance, and repair of the opened instrument under voltage should be avoided as much as possible and, when inevitable, should be carried out only by a skilled person who is aware of the hazard involved.

8-14. Capacitors inside the instrument may still be charged even if the instrument has been disconnected from its source of power.

WARNING

LINE VOLTAGE IS ALWAYS PRESENT AT THE POWER CORD CONNECTOR, AC LINE FUSE AND TRANSFORMER WHENEVER THE LINE CORD IS ATTACHED. UNPLUGGING THE POWER CORD IS NECESSARY TO REMOVE ALL POWER FROM THE INSTRUMENT.

8-15. Whenever it is likely that grounding or fuse protection has been impaired, the HP 5384A/HP must be made inoperative and secured against any unintended operation.

WARNING

THE SERVICE INFORMATION IS OFTEN USED WITH POWER SUPPLIED AND PROTECTIVE COVERS. REMOVED FROM THE HP 5384A/HP 5385A. ENERGY AVAILABLE AT MANY POINTS MAY, IF CONTACTED, RESULT IN PERSONAL INJURY.

8-16. Safety Symbols

8-17. The following safety symbols shown in *Figure 8-1* are used on equipment and in manuals:

8-18. RECOMMENDED TEST EQUIPMENT

8-19. Test equipment and test equipment accessories required to maintain the HP 5384A/HP 5385A are listed in *Table 1-2*. Equipment other than that listed may be used if it meets the critical specifications.

8-20. SERVICE AIDS

8-21. Pozidriv Screwdrivers

8-22. Many screws in the counter appear to be Phillips, but are not. To avoid damage to the screw slots, pozidriv screwdrivers should be used.

8-23. Nut Drivers

8-24. The BNC input connectors on the front and rear panels have ring nuts to hold them in place. To remove or tighten the nuts without damaging the panel, place tape on the end of the nut driver to act as a cushion.

8-25. Service Aids on Printed Circuit Boards

8-26. The servicing aids include test points, transistor and integrated circuit designations, adjustment callouts, and assembly stock numbers.

8-27. After Service Safety Checks

8-28. Visually inspect interior of instrument for any signs of abnormal internally generated heat, such as discolored printed circuit boards or components, damaged insulation, or evidence of arcing. Determine and remedy cause of any such condition.

8-29. Using a suitable ohmmeter, check resistance from the front and rear panels to ground pin on power cord plug. The reading must be less than one ohm. Flex the power cord while making this measurement to determine whether intermittent discontinuities exist.

8-30. Check resistance from the front and rear panel BNC connector shells and neutral (tied together) with the power switch on and the power source disconnected. The minimum acceptable resistance is two megohms. Replace any component which results in a failure.

8-31. Check line fuse(s) to verify that a correctly rated fuse is installed.

WARNING

TO ASSURE THE INTEGRITY OF THE SAFETY GROUNDING CIRCUIT:

1. Verify the star washer and rear panel BNC connector nut are installed and securely tightened.
2. Verify the solder lug with green/yellow wire (soldered to the A1 board) is securely fastened between potentiometer R1 and the front panel.

8-32. HP 5384A and HP 5385A Disassembly Procedures

8-33. The following procedures describe how to disassemble the HP 5384A and HP 5385A counters.

- a. Remove the two plastic feet from the bottom rear of the counter. The removal instructions are molded into the bottom of each foot.
- b. Remove the dark green adhesive strips on each side near the front of the instrument.

c. Remove four 6-32 screws from the bottom cover of the instrument.

d. Gently lift the top cover up and off the instrument.

8-34. If there is an interface board in the instrument, follow the next three steps for disassembly. If there is no interface board present, skip the following three steps and continue with step "h".

e. Disconnect the ribbon cable from the mother board.

f. Remove the two screws on the rear panel that hold it in place.

g. Remove the interface board from the instrument by pressing in the plastic catch near the top of the support post and lifting up on the board.













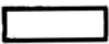

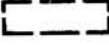

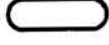

h. Remove two 6-32 screws that hold the motherboard to the bottom cover. Gently lift the motherboard from the bottom cover. The front and rear panels will remain attached to the motherboard.

8-35. Assembly Identification

8-36. The name, assembly number, and Hewlett-Packard part number of the HP 5384A and HP 5385A assemblies are listed in *Table 8-1*.

Table 8-1. Assembly Usage

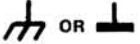
REF. DES.	PART NAME	HP PART NUMBER
A1	Main Board Assembly	05384-60001
A1	Main Board Assembly, TXCO (Opt. 001)	05384-60006
A1	Main Board Assembly, Oven Osc. (Opt. 004)	05384-60007
A1	Main Board Assembly, (TCXO Std)	05385-60001
A1	Main Board Assembly, Oven Osc. (Opt. 004)	05385-60003
A2	Display Assembly	
	Keyboard Assembly	05384-60102
	Liquid Crystal Display Assembly	05384-60104
A3	Battery Pack Assembly	05384-60003
A4	HP-IL Board Assembly	05006-60004
A5	HP-IB Board Assembly	05384-60005

	DANGEROUS VOLTAGE, EXCEEDS 1000 VOLTS	SYMBOLS		Knob Control
	FRONT PANEL LABEL			SCREWDRIVER ADJUST
	REAR PANEL LABEL			MAIN SIGNAL PATH
	INTERIOR AND PC BOARDS LABEL			FEEDBACK PATH
	WIPER MOVES TOWARD "CW" WHEN CONTROL IS ROTATED CLOCKWISE			TEST POINT
	PROTECTIVE CONDUCTOR TERMINAL			INSTRUCTION MANUAL REFERENCE
	CIRCUIT COMMON			ALTERNATING CURRENT
	IDENTIFIED COMMON			DIRECT CURRENT
	CHASSIS TERMINAL			ALTERNATING OR DIRECT CURRENT

PRINTED CIRCUIT BOARD IDENTIFICATION

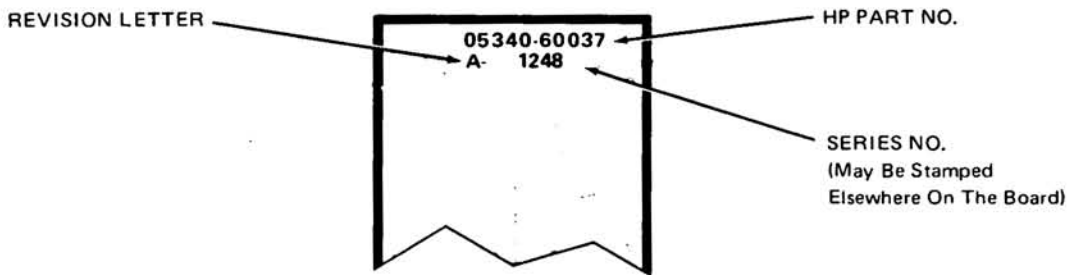

REFERENCE DESIGNATIONS

REFERENCE DESIGNATIONS WITHIN ASSEMBLIES ARE ABBREVIATED. ADD ASSEMBLY NUMBER TO ABBREVIATION FOR COMPLETE DESCRIPTION. JACKS ARE THE STATIONARY CONNECTORS AND PLUGS ARE THE MORE MOVEABLE OF TWO CONNECTORS.

ASSEMBLY	ABBREVIATION	COMPLETE DESCRIPTION
A25	C1	A25C1
A25A1	CR1	A25A1CR1
NO PREFIX	J3	J3

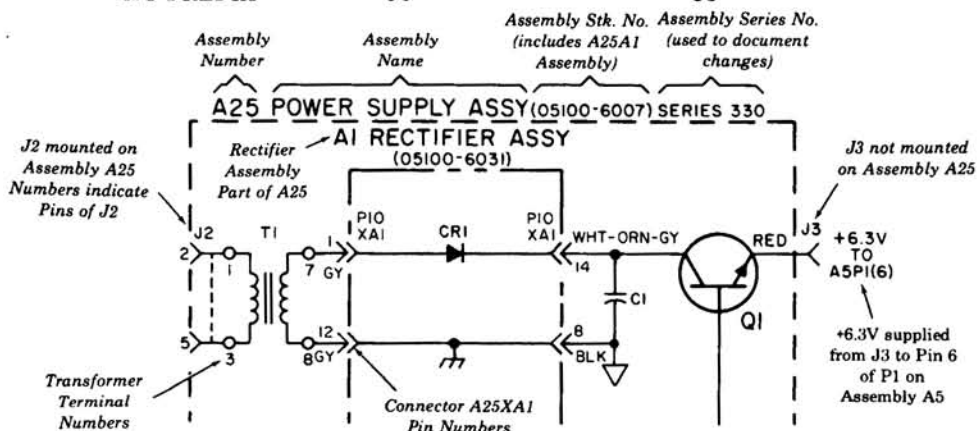

Figure 8-1. Schematic Diagram Notes

8-37. LOGIC SYMBOLS

8-38. The electronic symbology used in this book is explained starting in paragraphs 8-39.

8-39. EXPLANATION OF NEW LOGIC SYMBOLS (by F. A. Mann)*

8-40. Introduction

8-41. The International Electrotechnical Commission (IEC) has been developing a very powerful symbolic language that can show the relationship of each input of a digital logic circuit to each output without showing explicitly the internal logic. At the heart of the system is dependency notation, which will be explained in a later paragraph.

8-42. The system was introduced in the USA in a rudimentary form in IEEE/ANSI Standard Y32.14-1973. Lacking at that time a complete development of dependency notation, it offered little more than a substitution of rectangular shapes for the familiar distinctive shapes for representing the basic functions of AND, OR, negation, etc. This is no longer the case.

8-43. Internationally, Working Group 2 of IEC Technical Committee TC-3 is preparing a new document (Publication 617-12) that will consolidate the original work started in the mid 1960's and published in 1972 (Publication 117-15) and the amendments and supplements that have followed. Similarly for the USA, IEEE Committee SCC 11.9 is revising the publication IEEE Standard 91/ANSI Y32.14. Texas Instruments (and Hewlett-Packard) is participating in the work of both organizations and (a) Supplement to the (Texas Instruments) TTL Data Book introduces new logic symbols in anticipation of the new standards. When changes are made as the standards develop, future editions of the TTL Data Book will take those changes into account.

8-44. The following explanation of the new symbolic language is necessarily brief and greatly condensed from what the standards publications will finally contain. This (description) is not intended to be sufficient for those people who will be developing symbols for new devices. It is primarily intended to make possible the understanding of the symbols used in this book; comparing the symbols with functional block diagrams and/or function tables will further help that understanding.

8-45. Symbol Composition

8-46. A symbol comprises an outline or a combination of outlines together with one or more qualifying symbols (characters). The shape of the symbols (outline) is not significant. As shown in *Figure 8-2*, general qualifying symbols are used to tell exactly what logical operation is performed by the elements. *Table 8-2* shows the general qualifying symbols used in the T.I. TTL data book. Input lines are placed on the left and output lines are placed on the right. When an exception is made to that convention, the direction of signal flow is indicated by an arrow as shown in *Table 8-3*.

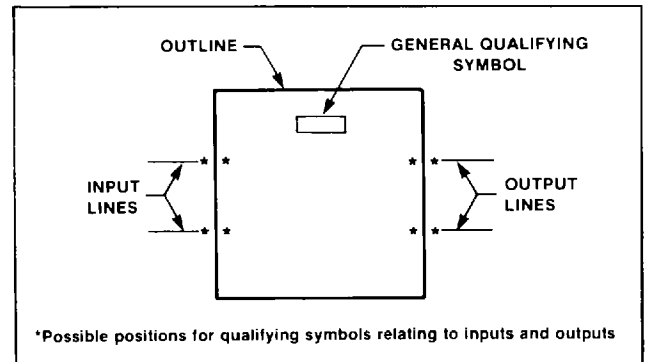

Figure 8-2. Test Setup for A3C37 and C23 Selection

8-47. All outputs of a single, unsubdivided element always have identical internal logic states determined by the function of the element except when otherwise indicated by an associated qualifying symbol or label inside the element.

8-48. The outlines of elements may be abutted (adjoining) or embedded (enclosed) in which case the following conventions apply. There is no logic connection between the elements when the line common to their outlines is in the direction of signal flow. There is at least one logic connection between the elements when the line common to their outlines is perpendicular to the direction of signal flow. The number of logic connections between elements will be clarified by the use of qualifying symbols and this is discussed further under that topic. If no indications are shown on either side of the common line, it is assumed there is only one connection.

8-49. When a circuit has one or more inputs that are common to more than one element of the circuit, the common-control block may be used. This is the only distinctively shaped outline used in the IEC system.

*From "1981 Supplement to the TTL Data Book for Design Engineers", copyright © 1981 Texas Instruments Incorporated. Reproduced by permission.

8-50. Figure 8-3 shows that unless otherwise qualified by dependency notation, an input to the common-control block is an input to each of the elements below the common-control block.

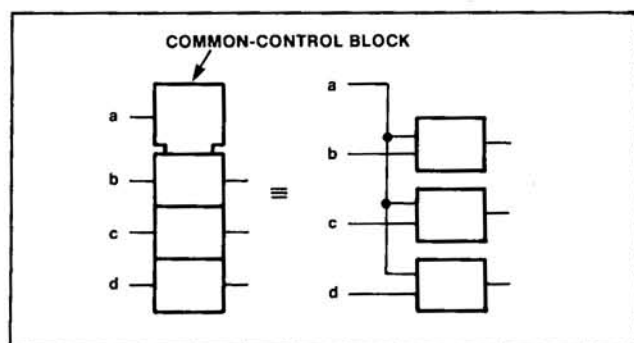

Figure 8-3. Illustration of Common-Control Block

8-51. A common-output depending on all elements of the array can be shown as the output of a common-

output element. Its distinctive visual feature is the double line at its top. In addition the common-output element may have other inputs as shown in Figure 8-4. The function of the common-output element must be shown by use of a general qualifying symbol.

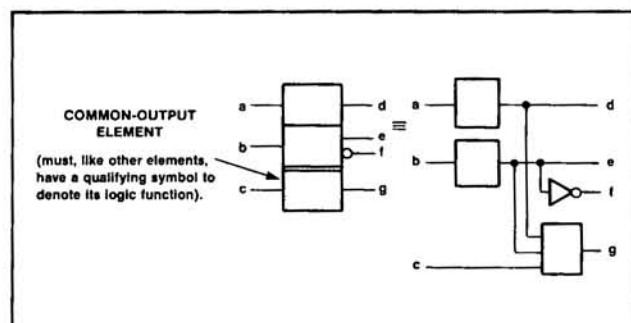

Figure 8-4. Illustration of Common-Output Element

Table 8-2. General Qualifying Symbols

SYMBOL	DESCRIPTION	EXAMPLE
&	AND gate or function.	SN7400
≥1	OR gate or function. The symbol was chosen to indicate that at least one active input is needed to activate the output.	SN7402
=1	Exclusive OR. One and only one input must be active to activate the output.	SN7486
=	Logic identity. All inputs must stand at same state.	SN74180
2k	An even number of inputs must be active.	SN74180
2k+1	An odd number of inputs must be active.	*
1	The one input must be active.	SN7404
≡ or -	A buffer or element with more than usual output capability (symbol is oriented in the direction of signal flow).	SN74S436
□	Schmitt trigger; element with hysteresis.	SN74LS18
X/Y	Coder, code Converter (DEC/BCD, BIN/OCT, BIN/7-SEG, etc.).	SN74LS347
MUX	Multiplexer/data selector.	SN74150
DMUX or DX	Demultiplexer.	SN74138
∑	Adder.	SN74LS385
P-Q	Subtractor.	SN74LS385
CPG	Look-ahead carry generator.	SN74182
π	Multiplier.	SN74LS384
COMP	Magnitude Comparator.	SN74LS682
ALU	Arithmetic logic unit.	SN74LS381
	Retriggerable monostable.	SN74LS422
1	Nonretriggerable monostable (one-shot)	SN74121

*Not all of the general qualifying symbols have been used in this book, but they are included here for the sake of completeness.

Table 8-2. General Qualifying Symbols (Continued)

G	Astable element. (Showing waveform is optional.)	SN74LS320
!G	Synchronously starting astable.	SN74LS624
G!	Astable element that stops with a completed pulse.	SN74LS624
SRGm	Shift register. m = number of bits.	SN74LS595
CTRm	Counter. m = number of bits; cycle length = 2m.	SN54LS590
CTR DIVm	Counter with cycle length = m.	SN74LS668
ROM	Read-only memory.	SN74187
RAM	Random-access read/write memory.	SN74170
FIFO	First-in, first-out memory.	SN74LS222

8-52. Qualifying Symbols

8-53. GENERAL QUALIFYING SYMBOLS. Table 8-2 shows the general symbols used in this data book. These characters are placed near the top center or the geometric center of a symbol or symbol element to define the basic function of the device represented by the symbol or of the element.

8-54. QUALIFYING SYMBOLS FOR INPUTS AND OUTPUTS. Qualifying symbols for inputs and outputs are shown in Table 8-3 and will be familiar to most users with the possible exception of the logic polarity and analog signal indicators. The older logic negation indicator means that the external 0 (zero) state produces the internal 1 state. The internal 1 state means the active state. Logic negation may be used in pure logic diagrams; in order to tie the external 1 and 0 logic states to the level H (high) and L (low), a statement of whether positive logic (1=H, 0=L) or

negative logic (1=L, 0=H) is being used is required or must be assumed. Logic polarity indicators eliminate the need for calling out the logic convention and are used in this (T.I.) data book in the symbology for actual devices. The presence of the triangular polarity indicator indicates that the Low logic level will produce the internal 1 state (the active state) or that, in the case of an output, the internal 1 state will produce the external Low level. Note how the active direction of transition for a dynamic input is indicated in positive logic, negative logic, and with polarity indication.

8-55. The internal connections between logic elements abutted together in a symbol may be indicated by the symbols shown. Each logic connection may be shown by the presence of qualifying symbols at one or both sides of the common line and if confusion can arise about the numbers of connections, use can be made of one of the internal connection symbols.

Table 8-3. Qualifying Symbols for Inputs and Outputs











	Logic negation at input. External 0 produces internal 1.
	Logic negation at output. Internal 1 produces external 0.
	Active-low input. Equivalent to  in positive logic.
	Active-low output. Equivalent to  in positive logic.
	Active-low input in the case of right-to-left signal flow.
	Active-low output in the case of right-to-left signal flow.
	Signal flow from right-to-left. If not otherwise indicated, signal flow is from left-to-right.
	Bidirectional signal flow.

Table 8-3. Qualifying Symbols for Inputs and Outputs (Continued)

		POSITIVE LOGIC	NEGATIVE LOGIC	POLARITY INDICATION
	Dynamic inputs active on indicated transition			NOT USED
		NOT USED	NOT USED	H to L
				L to H
	Nonlogic connection. A label inside the symbol will usually define the nature of this pin.			
	Input for analog signals.			
	Internal connection. 1 state on left produces 1 state on right.			
	Negated internal connection. 1 state on left produces 0 state on right.			
	Dynamic internal connection. Transition from 0 to 1 on left produces transitory 1 state on right.			
	Internal input (virtual input). It always stands at its internal 1 state unless affected by an overriding dependency relationship.			
	Internal output (virtual output). Its effect on an internal input to which it is connected is indicated by dependency notation.			

8-56. The internal (virtual) input is an input originating somewhere else in the circuit and is not connected directly to a terminal. The internal (virtual) output is likewise not connected directly to a terminal.

8-57. The application of internal inputs and outputs requires an understanding of dependency notation, which is explained in paragraph 8-66.

8-58. In an array of elements, if the same general qualifying symbol and the same qualifying symbols associated with inputs and outputs would appear inside each of the elements of the array, these qualifying symbols are usually shown only in the first element. This is done to reduce clutter and to save time in recognition. Similarly, large identical elements that are subdivided into smaller elements may each be represented by an unsubdivided outline. The SN54LS440 symbol illustrates this principle.

8-59. SYMBOLS INSIDE THE OUTLINE. Table 8-4 shows some symbols used inside the outline. Note particularly that open-collector, open-emitter, and three-state outputs have distinctive symbols. Also note that an EN input affects all the outputs of the circuit and has no effect on inputs. When an enable input affects only certain outputs and/or affects one or more inputs, a form of dependency notation will

indicate this (see paragraph 8-101). The effects of the EN input on the various types of outputs are shown.

8-60. It is particularly important to note that a D input is always the data input of a storage element. At its internal 1 state, the D input sets the storage element to its 1 state, and at its internal 0 state it resets the storage element to its 0 state.

8-61. The binary grouping symbol will be explained more fully in paragraph 8-137. Binary-weighted inputs are arranged in order and the binary weights of the least-significant and the most-significant lines are indicated by numbers. In this data book weights of input and output lines will be represented by powers of two usually only when the binary grouping symbol is used, otherwise, decimal numbers will be used. The grouped inputs generate an internal number on which a mathematical function can be performed or that can be an identifying number for dependency notation. See Figure 8-30. A frequent use is in addresses for memories.

8-62. Reversed in direction, the binary grouping symbol can be used with outputs. The concept is analogous to that for the inputs and the weighted outputs will indicate the internal number assumed to be developed within the circuit.

8-63. Other symbols are used inside the outlines in this data book in accordance with the IEC/IEEE standards but are not shown here. Generally these are associated with arithmetic operations and are self-explanatory.

8-64. When nonstandardized information is shown inside an outline, it is usually enclosed in square brackets [like these].

Table 8-4. Symbols Inside the Outline

	Postponed output (of a pulse-triggered flip-flop). The output changes when input initiating change (e.g., a C input) returns to its initial external state or level.	
	Bi-threshold input (input with hysteresis).	
	NPN open-collector or similar output that can supply a relatively low-impedance L level when not turned off. Requires external pull-up. Capable of positive-logic wired-AND connection.	
	Passive-pull-up output is similar to NPN open-collector output but is supplemented with a built-in passive pull-up.	
	NPN open-emitter or similar output that can supply a relatively low-impedance H level when not turned off. Requires external pull-down. Capable of positive-logic wired-OR connection.	
	Passive-pull-down output is similar to NPN open-emitter output but is supplemented with a built-in passive pull-down.	
	Three-state output.	
	Enable input When at its internal 1-state, all outputs are enabled. When at its internal 0-state, open-collector and open-emitter outputs are off, three-state outputs are at normally defined internal logic states and at external high-impedance state, all other outputs (e.g., totem-poles) are at the internal 0-state.	
J, K, R, S, T	Usual meanings associated with flip-flop (e.g., R = reset, T = toggle).	
	Data input to a storage element equivalent to:	
	Shift right (left) inputs, m = 1, 2, 3, etc. If m = 1, it is usually not shown.	
	Counting μ p (down) inputs, m = 1, 2, 3, etc. If m = 1, it is usually not shown.	
	Binary grouping. m is highest power of 2.	
	The contents-setting input, when active, causes the content of a register to take on the indicated value.	
	The content output is active if the content of the register is as indicated.	
	Input line grouping indicates two or more terminals used to implement a single logic input. e.g., The paired expander inputs of SN7450.	
	Fixed-state output always stands at its internal 1 state. For example, see SN74185.	

8-65. Dependency Notation

8-66. GENERAL EXPLANATION. Dependency notation is the powerful tool that sets the IEC symbols apart from previous systems and makes compact, meaningful, symbols possible. It provides the means of denoting the relationship between inputs, outputs, or inputs and outputs without actually showing all the elements and interconnections involved. The information provided by dependency notation supplements that provided by the qualifying symbols for an element's function.

8-67. In the convention for the dependency notation, use will be made of the terms "affecting" and "affected".

In cases where it is not evident which inputs must be considered as being the affecting or the affected ones (e.g., if they stand in an AND relationship), the choice may be made in any convenient way.

8-68. So far, 11 types of dependency have been defined and 10 of these are used in the Texas Instruments data book. They are listed below in the order in which they are presented and are summarized in Table 8-5.

Table 8-5. Summary of Dependency Notation

TYPE OF DEPENDENCY	LETTER SYMBOL*	AFFECTING INPUT AT ITS 1-STATE	AFFECTING INPUT AT ITS 0-STATE
Address	A	Permits action (address selected)	Prevents action (address not selected)
Control	C	Permits action	Prevents action
Enable	EN	Permits action	Prevents action of inputs. ◇ outputs off. ∇ outputs at external high impedance, no change in internal logic state. Other outputs at internal 0 state.
AND	G	Permits action	Imposes 0 state
Mode	M	Permits action (mode selected)	Prevents action (mode not selected)
Negate (X-OR)	N	Complements state	No effect.
RESET	R	Affected output reacts as it would to S = 0, R = 1	No effect
SET	S	Affected output reacts as it would to S = 1, R = 0	No effect
OR	V	Imposes 1 state	Permits action
Transmission	X	Bidirectionally connected input to output	Input to output bidirectionally not connected
Interconnection	Z	Imposes 1 state	Imposes 0 state

*These letter symbols appear at the AFFECTING input (or output) and are followed by a number. Each input (or output) AFFECTED by that input is labeled with that same number. When the labels EN, R, and S appear at inputs without the following numbers, the descriptions above do not apply. The action of these inputs is described under "Symbols Inside the Outline".

Paragraph Dependency Type or Other Subject

8-68	G, AND
8-72	General rules for dependency notation
8-80	V, OR
8-82	N, Negate, (Exclusive OR)
8-84	Z, Interconnection
8-87	X, Transmission
8-91	C, Control
8-94	S, Set and R, Reset
8-100	EN, Enable
8-104	M, Mode
8-117	A, Address

8-70. In Figure 8-5 input **b** is ANDed with input **a** and the complement of **b** is ANDed with **c**. The letter G has been chosen to indicate AND relationships and is placed at input **b**, inside the symbol. A number considered appropriate by the symbol designer (1 has been used here) is placed after the letter G and also at each affected input. Note the bar over the 1 at input **c**.

8-71. In Figure 8-6, output **b** affects input **a** with an AND relationship. The lower example shows that it is the internal logic state of **b**, unaffected by the negation sign, that is ANDed. Figure 8-7 shows input **a** to be ANDed with a dynamic input **b**.

8-72. The rules for G dependency can be summarized thus:

When a G_m input or output (m is a number) stand at its internal 1 state, all inputs and outputs affected by G_m stand at their normally defined internal logic states. When the G_m input or output stands at its 0 state, all inputs and outputs affected by G_m stand at their internal 0 states.

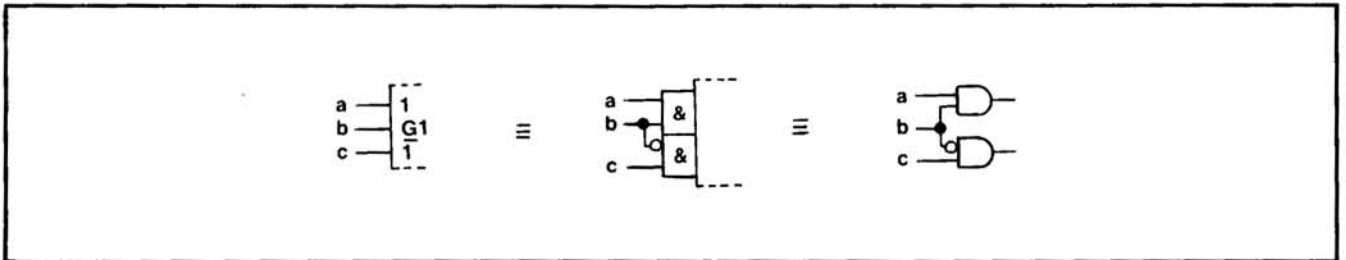

Figure 8-5. G Dependency Between Inputs

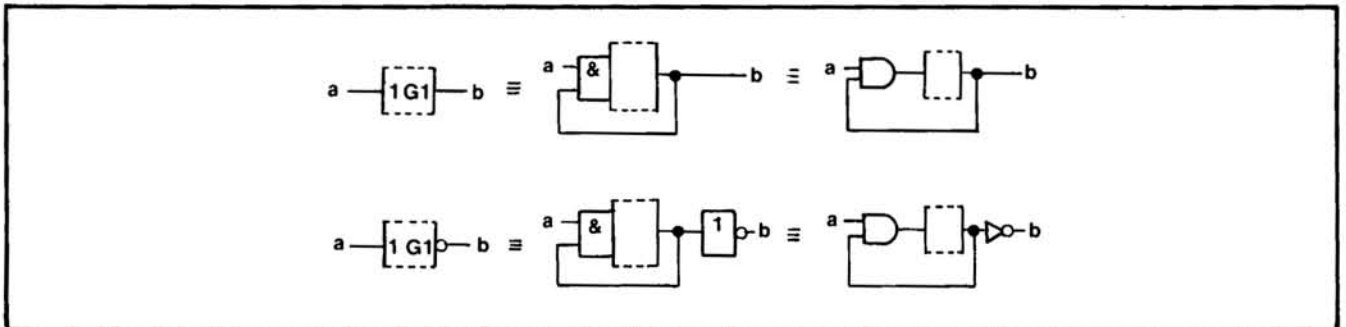

Figure 8-6. G Dependency Between Outputs and Inputs

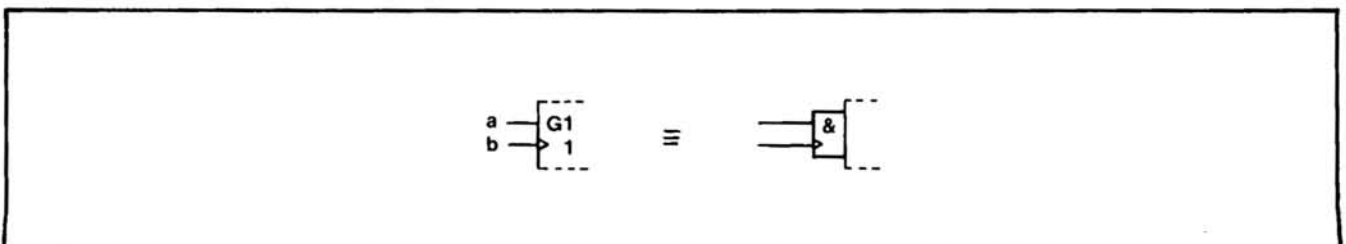

Figure 8-7. G Dependency with A Dynamic Input

8-73. CONVENTIONS FOR THE APPLICATION OF DEPENDENCY NOTATION IN GENERAL. The rules for applying dependency relationships in general follow the same pattern as was illustrated for G dependency.

8-74. Application of dependency notation is accomplished by:

- Labeling the input (or output) affecting other inputs or outputs with the letter symbol indicating the relationship involved (e.g., G for AND) followed by an identifying number, appropriately chosen, and;
- Labeling each input or output affected by that affecting input (or output) with the same number.

8-75. If it is the complement of the internal logic state of the affecting input or output that does the affecting, then a bar is placed over the identifying numbers at the affected inputs or outputs. See Figure 8-5.

8-76. If two affecting inputs or outputs have the same letter and same identifying number, they stand in an OR relationship to each other. See Figure 8-8.

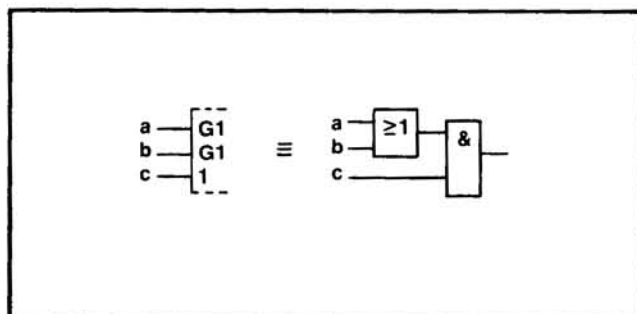

Figure 8-8. OR'ed Affecting Inputs

8-77. If the affected input or output requires a label to denote its function (e.g., "D"), this label will be prefixed by the identifying number of the affecting input. See Figure 8-14.

8-78. If an input or output is affected by more than one affecting input, the identifying numbers of each of the affecting inputs will appear in the label of the affected one, separated by commas. The normal reading order of these numbers is the same as the sequence of the affecting relationships. See Figure 8-14.

8-79. If the labels denoting the functions of affected inputs or outputs must be numbers (e.g., outputs of a coder), the identifying numbers to be associated with both affecting inputs and affected inputs or outputs will be replaced by another character selected to avoid ambiguity, e.g., Greek letters. See Figure 8-9.

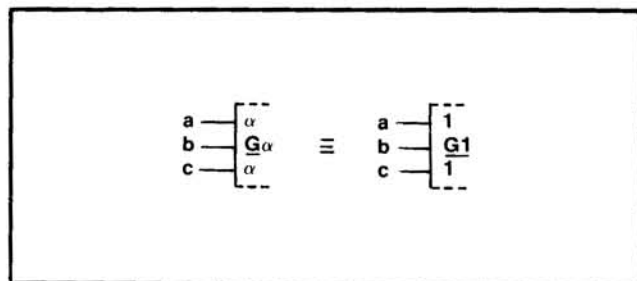

Figure 8-9. Substitution for Numbers

8-80. V (OR) DEPENDENCY. The symbol denoting OR dependency is the letter V. See Figure 8-10.

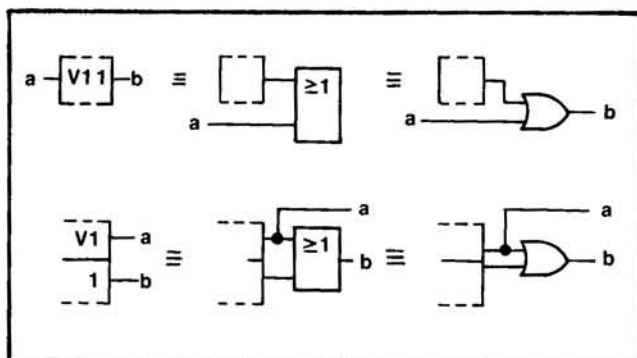

Figure 8-10. V (OR) Dependency

8-81. When a V_m input or output stands at its internal 1 state, all inputs and outputs affected by V_m stand at their internal 1 states. When the V_m input or output stands at its internal 0 state, all inputs and outputs affected by V_m stand at their normally defined internal logic states.

8-82. N (NEGATE, X-OR) DEPENDENCY. The symbol denoting negate dependency is the letter N. See Figure 8-11. Each input or output affected by an N_m input or output stands in an exclusive-OR relationship with the N_m input or output.

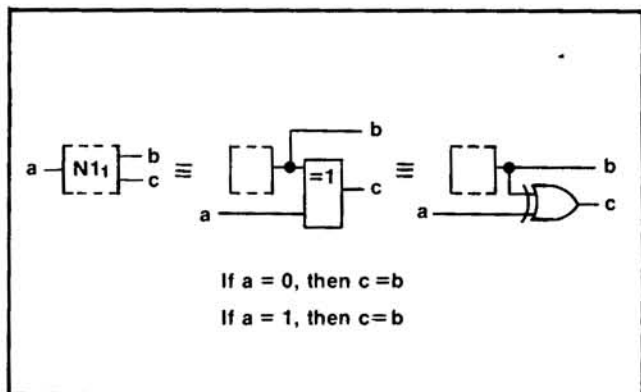

Figure 8-11. N (Negate, X-OR) Dependency

8-83. When an N_m input or output stands at its internal 1 state, the internal logic state of each input and each output affected by N_m is the complement of what it would otherwise be. When an N_m input or output stands at its internal 0 state, all inputs and outputs affected by N_m stand at their normally defined internal logic states.

8-84. Z (INTERCONNECTION) DEPENDENCY. The symbol denoting interconnection dependency is the letter Z.

8-85. Interconnecting dependency is used to indicate the existence of internal logic connections between inputs, outputs, internal inputs, and/or internal outputs.

8-86. The internal logic state of an input or output affected by a Z_m input or output will be same as the internal logic state of the Z_m input or output, unless modified by additional dependency notation. See Figure 8-12.

NOTE

Paragraphs 8-87 to 8-90 and Figure 8-13 are not taken from Texas Instruments publications.

8-87. X (TRANSMISSION) DEPENDENCY. The symbol X denotes transmission dependency.

8-88. When an X_m input or an X_m output stands at its internal 1 state, all input-output lines affected by this X_m input or X_m output are bidirectionally connected together and stand at the same internal logic state or analog signal level.

8-89. When a X_m input or X_m output stands at its internal 0 state, the connection associated with this set of dependency notation is broken.

8-90. If a stands at its 1 state, there is a bidirectional connection between b and c. If a stands at its 0 state, there is a bidirectional connection between c and d. See Figure 8-13.

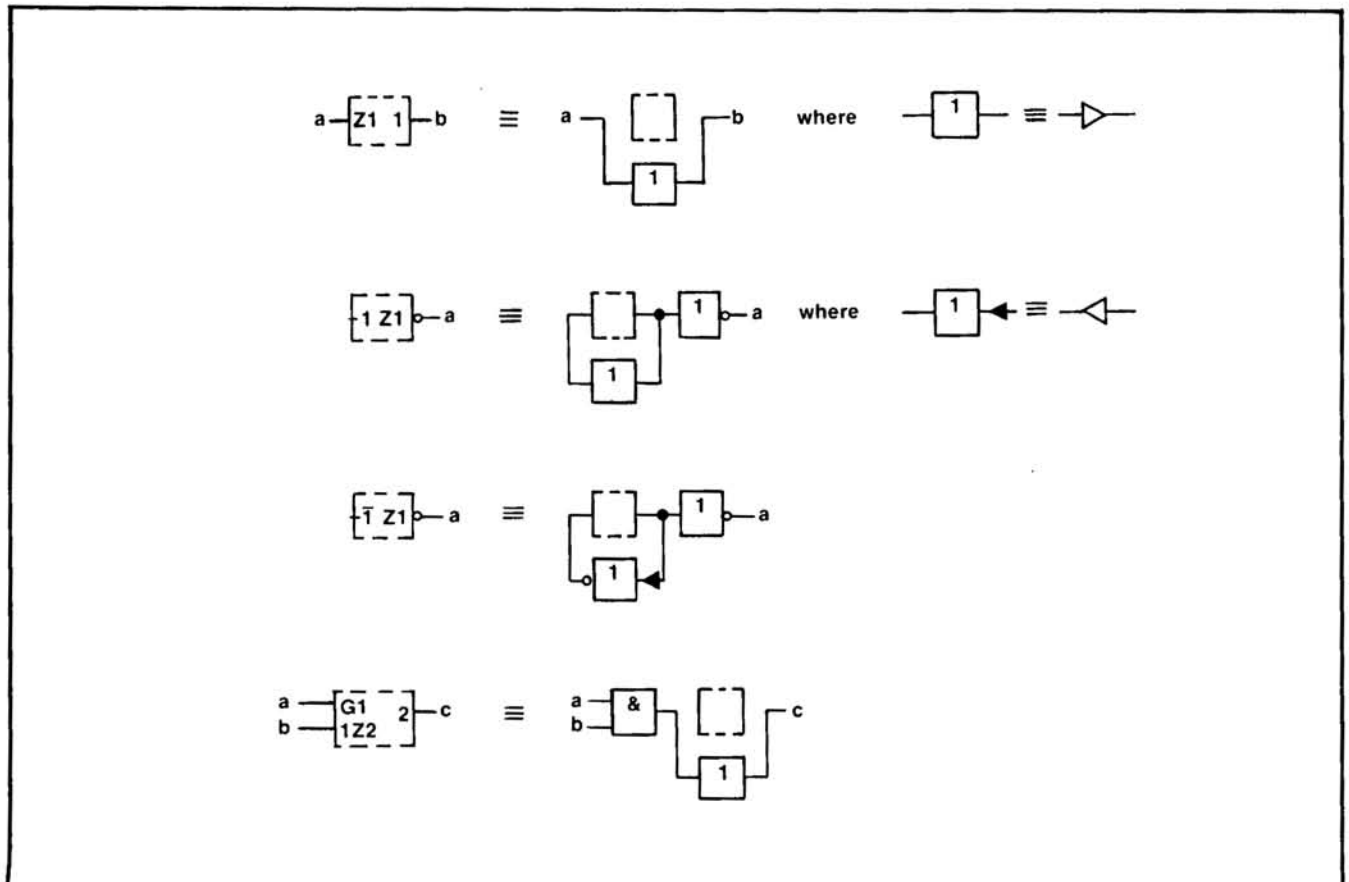

Figure 8-12. Z (Interconnection) Dependency

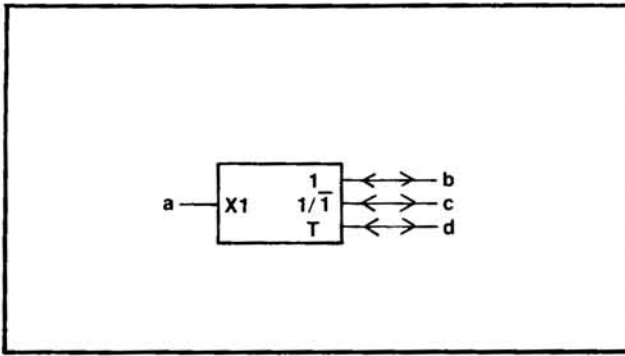

Figure 8-13. X (Transmission) Dependency

8-91. C (CONTROL) DEPENDENCY. The symbol denoting control dependency is the letter C.

8-92. Control inputs are usually used to enable or disable the data (D, J, K, R, or S) inputs of storage elements. They may take on their internal 1 states (be active) either statically or dynamically. In the latter case the dynamic input symbol is used as shown in the third example of Figure 8-14.

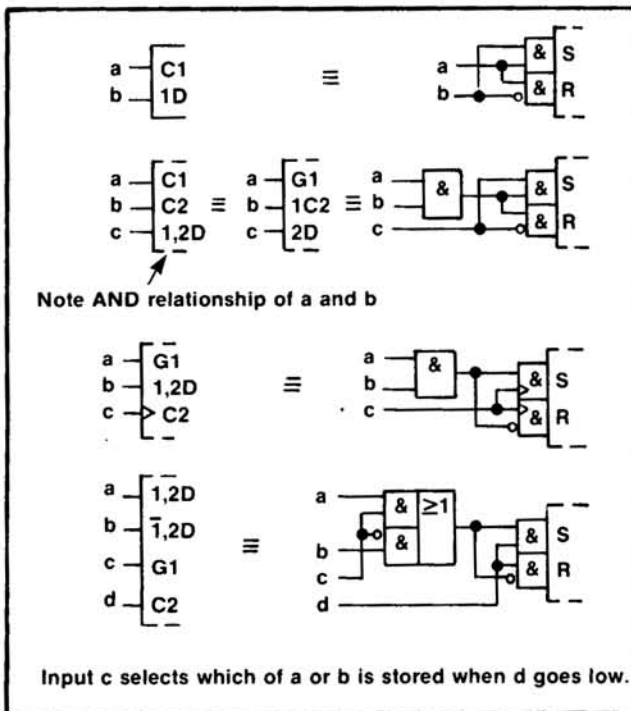

Figure 8-14. C (Control) Dependency

8-93. When a C_m input or output stands at its internal 1 state, the inputs affected by C_m have their normally defined affect on the function of the element, i.e., these inputs are enabled. When a C_m input or output stands at its internal 0 state, the inputs affected by C_m are disabled and have no effect on the function of the element.

8-94. S (SET) and R (RESET) DEPENDENCIES. The symbol denoting set dependency is the letter S. The symbol denoting reset dependency is the letter R.

8-95. Set and reset dependencies are used if it is necessary to specify the effect of the combination $R=S=1$ on a bistable element. Case 1 in Figure 8-15 does not use S or R dependency.

8-96. When an S_m input is at its internal 1 state, outputs affected by the S_m input will react, regardless of the state of an R input, as they normally would react to the combination $S=1, R=0$. See cases 2, 4, and 5 in Figure 8-15.

8-97. When an R_m input is at its internal 1 state, outputs affected by the R_m input will react, regardless of the state of an S input, as they normally would react to the combination $S=0, R=1$. See cases 3, 4, and 5 in Figure 8-15.

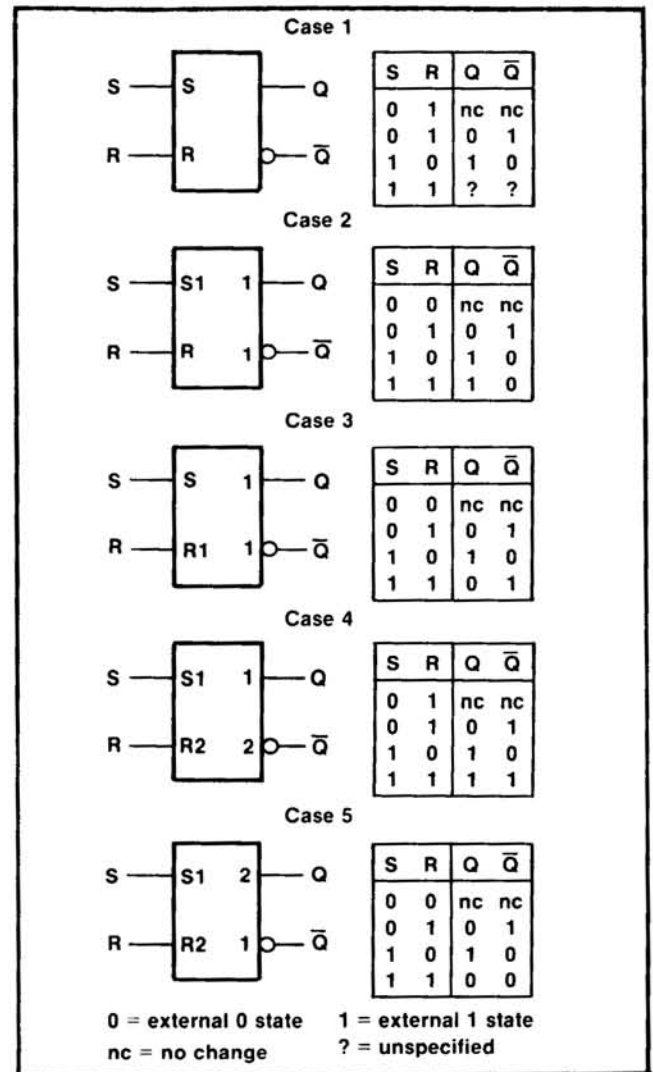

Figure 8-15. S (Set) and R (Reset) Dependencies

8-98. When an S_m or R_m input is at its internal 0 state, it has no effect.

8-99. Note that the noncomplementary output patterns in cases 4 and 5 are only pseudostable. The simultaneous return of the inputs to $S=R=0$ produces an unforeseeable stable and complementary output pattern.

8-100. EN (ENABLE) DEPENDENCY. The symbol denoting enable dependency is the combination of letters EN.

8-101. An EN_m input has the same effect on outputs as an EN input, see paragraph 8-52, but it affects only those outputs labeled with the identifying number m . It also affects those inputs labeled with the identifying number m . By contrast an EN input affects all outputs and no inputs. The effect of an EN_m input on an affected input is identical to that of a C_m input. See Figure 8-16.

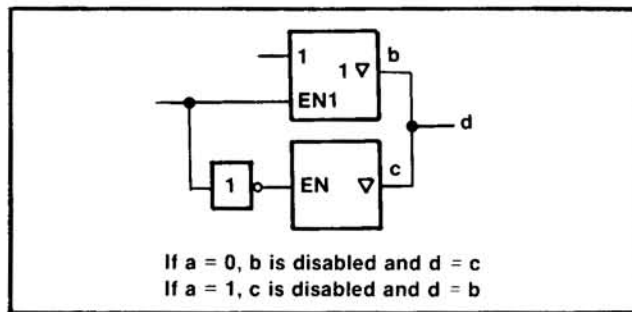

Figure 8-16. EN (Enable) Dependency

8-102. When an EN_m input stands at its internal 1 state, the inputs affected by EN_m have their normally defined effect on the function of the element and the outputs affected by this input stand at their normally defined internal logic states, i.e., these inputs and outputs are enabled.

8-103. When an EN_m input stands at its internal 0 state, the inputs affected by EN_m are disabled and have no effect on the function of the element, and the outputs affected by EN_m are also disabled. Open-collector outputs are turned off, three-state outputs stand at their normally defined internal logic states but externally exhibit high impedance, and all other outputs (e.g., totem-pole outputs) stand at their internal 0 states.

8-104. M (MODE) DEPENDENCY. The symbol denoting mode dependency is the letter M.

8-105. Mode dependency is used to indicate that the effects of particular inputs and outputs of an element depend on the mode in which the element is operating.

8-106. If an input or output has the same effect in different modes of operation, the identifying numbers of the relevant affecting M_m inputs will appear in the label of that affected input or output between parentheses and separated by solidi. See Figure 8-21.

8-107. M DEPENDENCY AFFECTING INPUTS. M dependency affects inputs the same as C dependency. When an M_m input or M_m output stands at its internal 1 state, the inputs affected by this M_m input or M_m output have their normally defined effect on the function of the element, i.e., the inputs are enabled.

8-108. When an M_m input or M_m output stands at its internal 0 state, the inputs affected by this M_m input or M_m output have no effect on the function of the element. When an affected input has several sets of labels separated by solidi (e.g., $C4/2-/3+$), any set in which the identifying number of the M_m input or M_m output appears has no effect and is to be ignored. This represents disabling of some of the functions of a multifunction input.

8-109. The circuit in Figure 8-17 has two inputs, b and c , that control which one of four modes (0, 1, 2, or 3) will exist at any time. Inputs d , e , and f are D inputs subject to dynamic control (clocking) by the a input. The numbers 1 and 2 are in the series chosen to indicate the modes so inputs e and f are only enabled in mode 1 (for parallel loading) and input d is only enabled in mode 2 (for serial loading). Note that input a has three functions. It is the clock for entering data. In mode 2, it causes right shifting of data, which means a shift away from the control block. In mode 3, it causes the contents of the register to be incremented by one count.

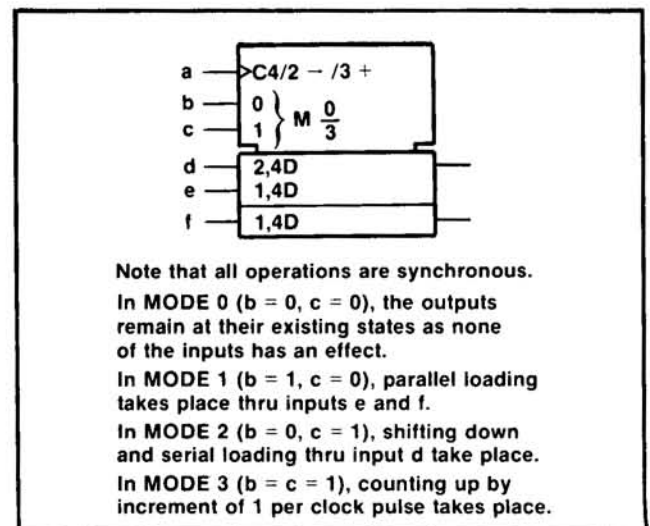

Figure 8-17. M (Mode) Dependency

8-110. **M DEPENDENCY AFFECTING OUTPUTS.** When an *Mm* input or *Mm* output stands at its internal 1 state, the affected outputs stand at their normally defined internal logic states, i.e., the outputs are enabled.

8-111. When an *Mm* input or *Mm* output stands at its internal 0 state, at each affected output any set of labels containing the identifying number of that *Mm* input or *Mm* output has no effect and is to be ignored. When an output has several different sets of labels separated by solidi (e.g., 2, 4/3, 5), only those sets in which the identifying number of this *Mm* input or *Mm* output appears are to be ignored.

8-112. In Figure 8-18, mode 1 exits when the *a* input stands at its internal 1 state. The delayed output symbol is effective only in mode 1 (when input *a* = 1) in which case the device functions as a pulse-triggered flip-flop. See paragraphs 8-125 through 8-129. When input *a* = 0, the device is not in mode 1 so the delayed output symbol has no effect and the device functions as a transparent latch.

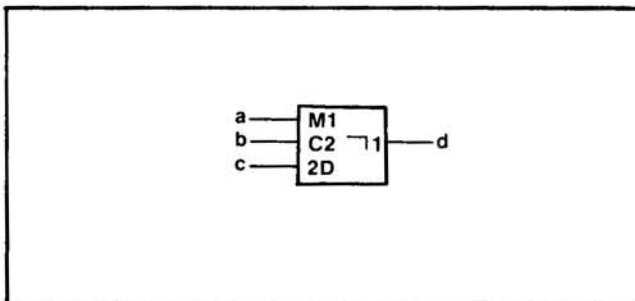

Figure 8-18. Type of Flip-Flop Determined by Mode

8-113. In Figure 8-19, if input *a* stands at its internal 1 state establishing mode 1, output *b* will stand at its internal 1 state only when the content of the register equal 9. Since output *b* is located in the common-control block with no defined function outside of mode 1, this output will stand at its internal 0 state when input *a* stands at its internal 0 state, regardless of the register content.

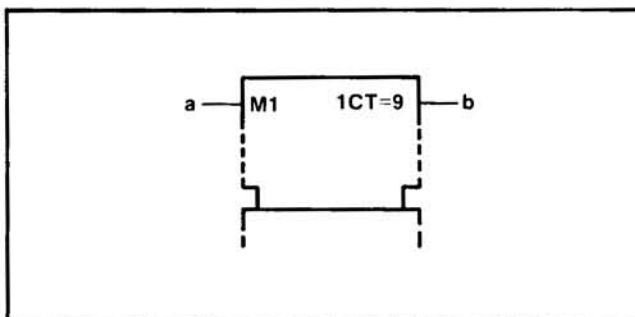

Figure 8-19. Disabling an Output of the Common Control Block

8-114. In Figure 8-20, if input *a* stands at its internal 1 state establishing mode 1, output *b* will stand at its internal 1 state only when the content of the register equals 15. If input *a* stands at its internal 0 state, output *b* will stand at its internal 1 state only when the content of the register equals 0.

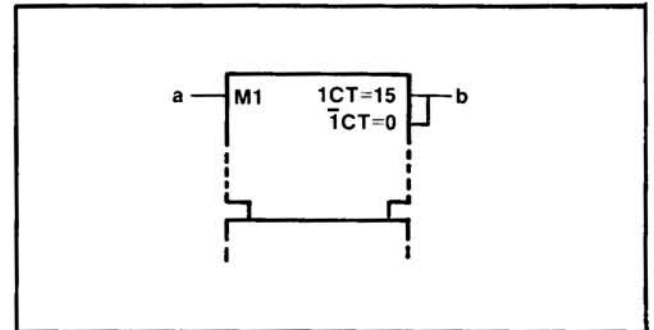

Figure 8-20. Determining an Output Function

8-115. In Figure 8-21 inputs *a* and *b* are binary weighted to generate the numbers 0, 1, 2, or 3. This determines which one of the four modes exists.

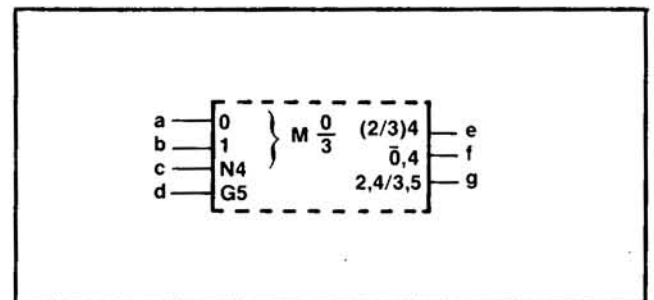

Figure 8-21. Dependent Relationship Affected by Mode

8-116. At output *e* the label set causing negation (if *c* = 1) is effective only in modes 2 and 3. In modes 0 and 1 this output stands at its normally defined state as if it had no labels. At output *f* the label set has effect when the mode is not 0 so output *e* is negated (if *c* = 1) in modes 1, 2, and 3. In mode 0 the label set has no effect so the output stands at its normally defined state. In this example 0, 4 is equivalent to (1/2/3)4. At output *g* there are two label sets. the first set, causing negation (if *c* = 1), is effective only in mode 2. The second set, subjecting *g* to AND dependency on *d*, has effect only in mode 3.

8-117. **A (ADDRESS) DEPENDENCY.** The symbol denoting address dependency is the letter A.

8-118. Address dependency provides a clear representation of those elements, particularly memories, that use address control inputs to select specified sections of a multidimensional array. Such a section of a memory array is usually called a word. The purpose

of address dependency is to allow a symbolic presentation of the entire array. An input of the array shown at a particular element of this general section is common to the corresponding elements of all selected sections of the array. An output of the array shown at a particular element of this general section is the result of the OR function of the outputs of the corresponding elements of selected sections. If the label of an output of the array shown at a particular element of this general section indicates that this output is an open-circuit output or a three-state output, then this indication refers to the output of the array and not to those of the sections of the array.

8-119. Inputs that are not affected by any affecting address input have their normally defined effect on all sections of the array, whereas inputs affected by an address input have their normally defined effect only on the section selected by that address input.

8-120. An affecting address input is labeled with the letter A followed by an identifying number that corresponds with the address of the particular section of the array selected by this input. Within the general section presented by the symbol, inputs and outputs affected by an A_m input are labeled with the letter A, which stands for the identifying numbers, i.e., the addresses, of the particular sections.

8-121. Figure 8-22 shows a 3-word by 2-bit memory having a separate address line for each word and uses EN dependency to explain the operation. To select word 1, input a is taken to its 1 state, which establishes mode 1. Data can now be clocked into the inputs marked "1, 4D". Unless words 2 and 3 are also selected, data cannot be clocked in at the inputs marked "2, 4D" and "3, 4D". The outputs will be the OR functions of the selected outputs, i.e., only those enabled by the active EN functions.

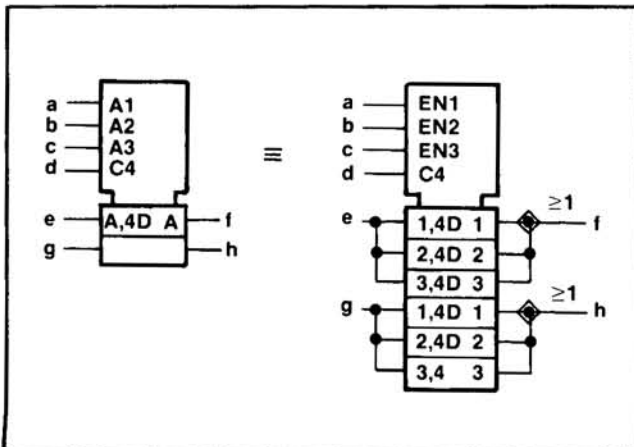

Figure 8-22. A (Address) Dependency

8-122. The identifying numbers of affecting address inputs correspond with the addresses of the sections selected by these inputs. They need not necessarily differ from those of other affecting dependency-inputs (e.g., G, V, N, ...), because in the general section presented by the symbol they are replaced by the letter A.

8-123. If there are several sets of affecting A_m inputs for the purpose of independent and possibly simultaneous access to sections of the array, then the letter A is modified to 1A, 2A, ..., because they have access to the same sections of the array, these sets of A inputs may have the same identifying numbers.

8-124. Figure 8-23 is another illustration of the A (Address) dependency.

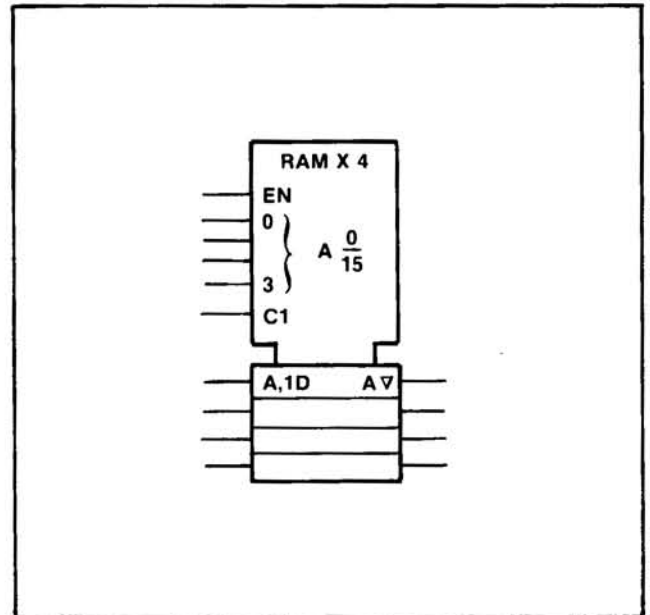

Figure 8-23. RAM Example*

*Array of 16 sections of four transparent latches with three-state outputs comprising a 16-word by four-bit random access memory.

8-125. Bistable Elements

8-126. The dynamic input symbol, the postponed output symbol, and dependency notation provide the tools to differentiate four main types of bistable elements and make synchronous and asynchronous inputs easily recognizable. See Figure 8-24. The first column shows the essential distinguishing features; the other columns show examples.

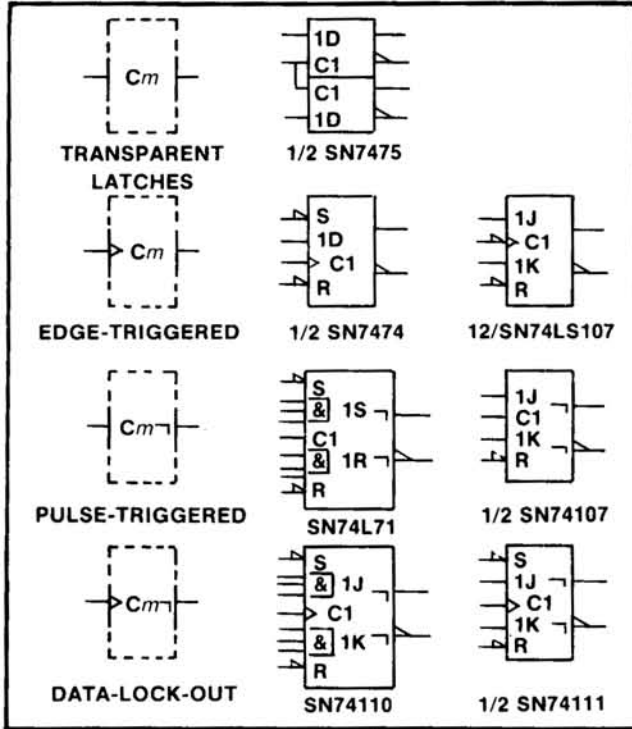

Figure 8-24. Four Types of Bistable Circuits

8-127. Transparent latches have a level-operated control input. The D input is active as long as the C input is at its internal 1 state. The outputs respond immediately. Edge-triggered elements accept data from D, J, K, R, or S inputs on the active transition of C. Pulse-triggered elements require the setup of data before the start of the control pulse; the C input is considered static since the data must be maintained as long as C is at its 1 state. The output is postponed until C returns to its 0 state. The data-lock-out element is similar to the pulse-triggered version except that the C input is considered dynamic in that shortly after C goes through its active transition, the data inputs are disabled and data does not have to be held. However, the output is still postponed until the C input returns to its initial external level.

8-128. Notice that synchronous inputs can be readily recognized by their dependency (1D, 1J, 1K, 1S, 1R) compared to the asynchronous inputs (S,R), which are not dependent on the C inputs.

8-129. Coders

8-130. The general symbol for a coder or code converter is shown in Figure 8-25. X and Y may be replaced by appropriate indications of the code used to represent the information at the inputs and at the outputs, respectively.

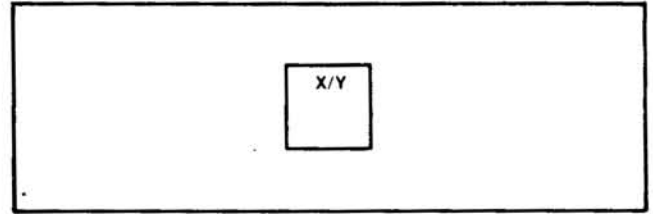

Figure 8-25. Coder General Symbol

8-131. Indication of code conversion is based on the following rule:

Depending on the input code, the internal logic states of the inputs determine an internal value. This value is reproduced by the internal logic states of the outputs, depending on the output code.

8-132. The indication of the relationships between the internal logic states of the inputs and the internal value is accomplished by:

- a. Labeling the inputs with numbers. In this case the internal value equals the sum of the weights associated with those inputs that stand at their internal 1 state, or by;
- b. Replacing X by an appropriate indication of the input code and labeling the inputs with characters that refer to this code.

8-133. The relationships between the internal value and the internal logic states of the outputs are indicated by:

- a. Labeling each output with a list of numbers representing those internal values that lead to the internal 1 state of that output. These numbers shall be separated by solidi (slant:/) as in Figure 8-26. This labeling may also be applied when Y is replaced by a letter denoting a type of dependency (see paragraphs 8-135 and 8-136). If a continuous range of internal values produces the internal 1 state of an output, this can be indicated by two numbers that are inclusively the beginning and the end of the range, with these two numbers separated by three dots, e.g., 4...9 = 4/5/6/7/8/9, or by;

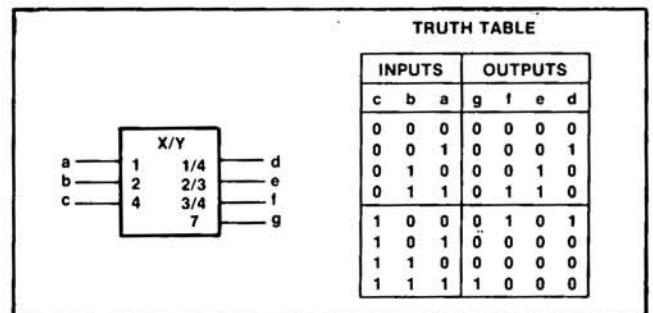

Figure 8-26. An X-Y Code Converter

b. Replacing Y by an appropriate indication of the output code and labeling the outputs with characters that refer to this code as in Figure 8-27.

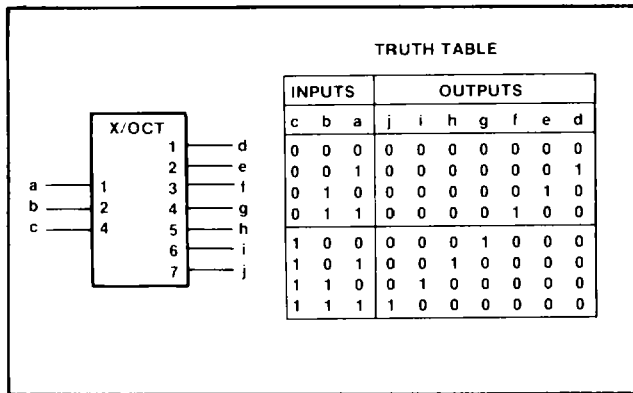

Figure 8-27. An X-Octal Code Converter

8-134. Alternatively, the general symbol may be used together with an appropriate reference to a table in which the relationship between the inputs and outputs is indicated. This is a recommended way to symbolize a PROM after it has been programmed.

8-135. USE OF A CODER TO PRODUCE AFFECTING INPUTS. If often occurs that a set of affecting inputs for dependency notation is produced by decoding the signals on certain inputs to an element. In such a case use can be made of the symbol for a coder as an embedded symbol. See Figure 8-28.

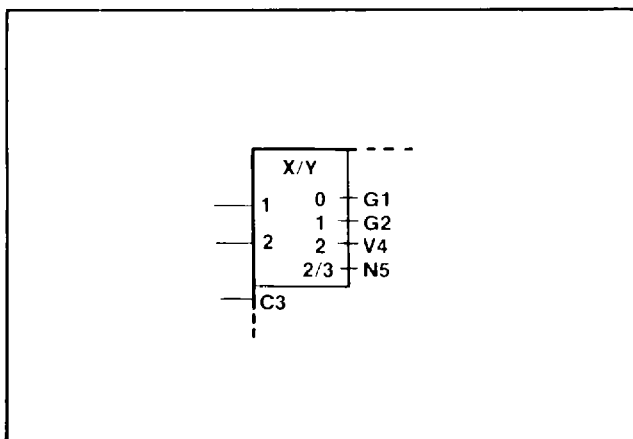

Figure 8-28. Coder Producing Several Dependencies

8-136. If all affecting inputs produced by a coder are of the same type and their identifying numbers correspond with the numbers shown at the outputs of the coder, Y (in the qualifying symbol X/Y) may be replaced by the letter denoting the type of dependency. The indications of the affecting inputs should then be omitted. See Figure 8-29.

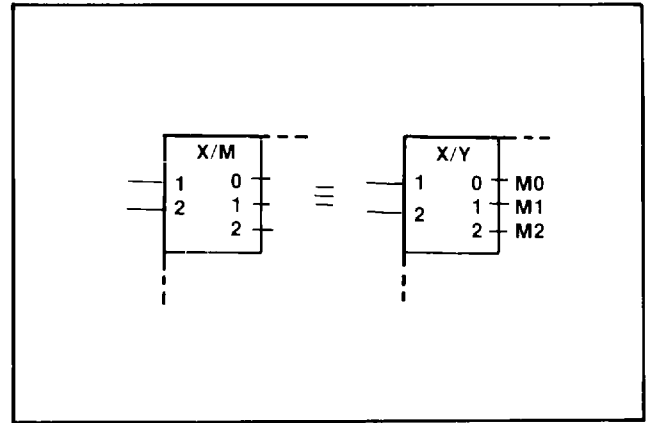

Figure 8-29. Coder Producing One Type of Dependency

8-137. Use of Binary Grouping to Produce Affecting Inputs

8-138. If all affecting inputs produced by a coder are of the same type and have consecutive identifying numbers not necessarily corresponding with the numbers that would have been shown at the outputs of the coder, use can be made of the binary grouping symbol (see paragraph 8-61). k external lines effectively generate $2k$ internal inputs. The bracket is followed by the letter denoting the type of dependency followed by m_1/m_2 . The m_1 is to be replaced by the smallest identifying number and the m_2 by the largest one, as shown in Figure 8-30.

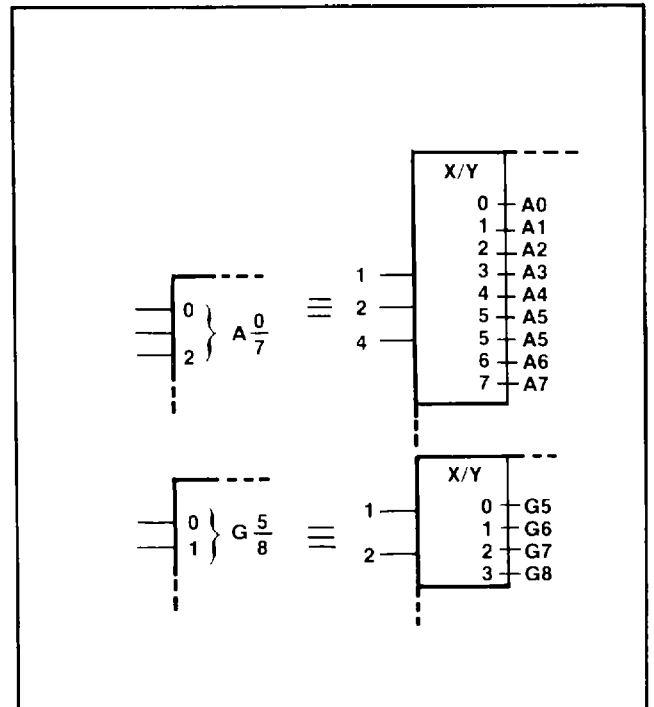

Figure 8-30. Use of Binary Grouping Symbol

8-139. Sequence of Input Labels

8-140. If an input having a single functional effect is affected by other inputs, the qualifying symbol (if there is any) for that functional effect is preceded by the labels corresponding to the affecting inputs. The left-to-right order of these preceding labels is the order in which the effects or modifications must be applied. The affected input has no functional effect on the element if the logic state of any one of the affecting inputs, considered separately, would cause the affected input to have no effect, regardless of the logic states of other affecting inputs.

8-141. If an input has several different functional effects or has several different sets of affecting inputs, depending on the mode of action, the input may be shown as often as required. However, there are cases in which this method of presentation is not advantageous. In those cases the input may be shown once with the different sets of labels separated by solidi. See *Figure 8-31*. No meaning is attached to the order of these sets of labels. If one of the functional effects of an input is that of an unlabeled input of the element, a solidus will precede the first set of labels shown.

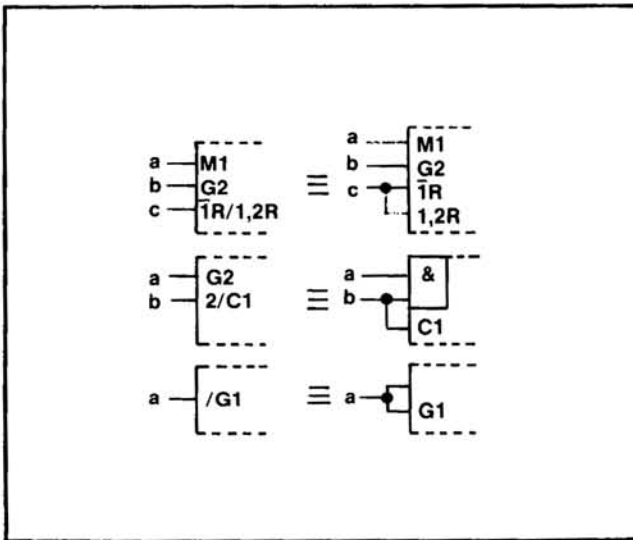

Figure 8-31. Input Labels

8-142. If all inputs of a combinational element are disabled (caused to have no effect on the function of the element), the internal logic states of the outputs of the element are not specified by the symbol. If all inputs of a sequential element are disabled, the content of this element is not changed and the outputs remain at their existing internal logic states.

8-143. Input labels may be factored using algebraic techniques. See *Figure 8-32*.

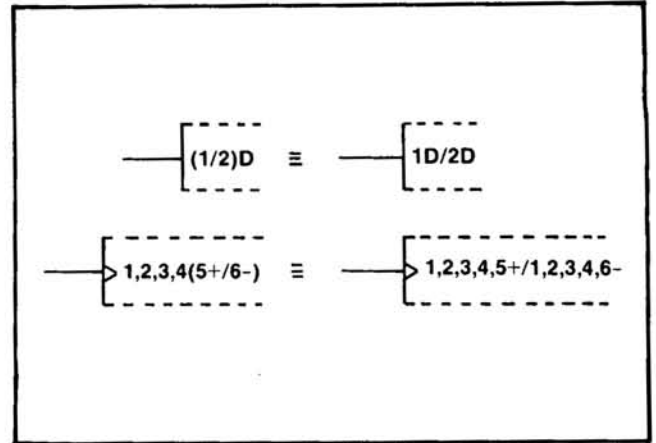

Figure 8-32. Factoring Input Labels

8-144. Sequence of Output Labels

8-144. If an output has a number of different labels, regardless of whether they are identifying numbers of affecting inputs or outputs or not, these labels are shown in the following order:

- a. If the postponed output symbol has to be shown, this comes first, if necessary preceded by the indications of the inputs to which it must be applied;
- b. Followed by the labels indicating modifications of the internal logic state of the output, such that the left-to-right order of these labels corresponds with the order in which their effects must be applied;
- c. Followed by the label indicating the effect of the output on inputs and other outputs of the element.

8-146. Symbols for open-circuit or three-state outputs, where applicable, are placed just inside the outside boundary of the symbol adjacent to the output line. See *Figure 8-33*.

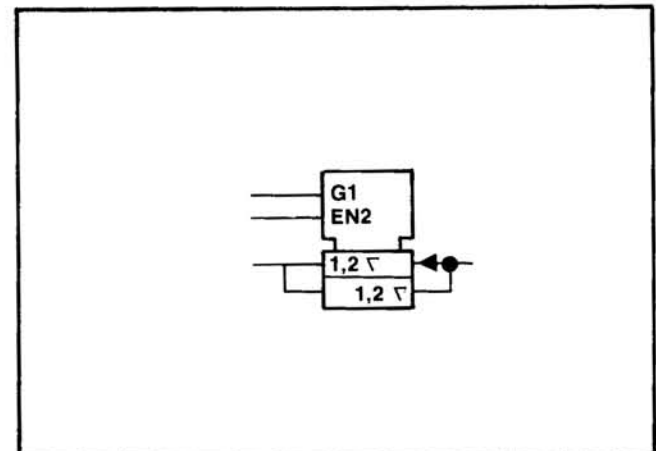

Figure 8-33. Placement of Three-State Symbols

8-147. If an output needs several different sets of labels that represent alternative functions (e.g., depending on the mode of action), these sets may be shown on different output lines that must be connected outside the outline. However, there are cases in which this method of presentation is not advantageous. In those cases the output may be shown once with the different sets of labels separated by solidi. See *Figure 8-34*.

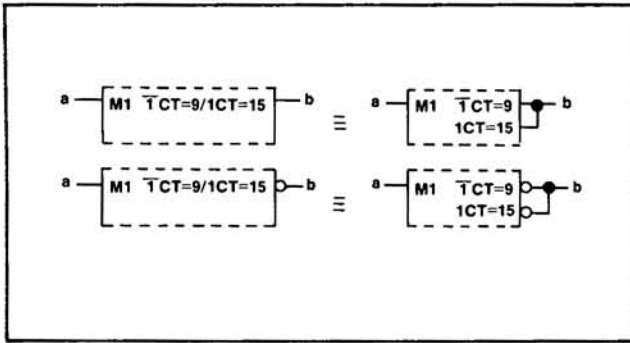

Figure 8-34. Output Labels

8-148. Two adjacent identifying numbers of affecting inputs in a set of labels that are not already separated by a nonnumeric character should be separated by a comma.

8-149. If a set of labels of an output not containing a solidus contains the identifying number of an affecting Mm input standing at its internal 0 state, this set of labels has no effect on that output.

8-150. Labels may be factored using algebraic techniques. See *Figure 8-35* for output label factoring.

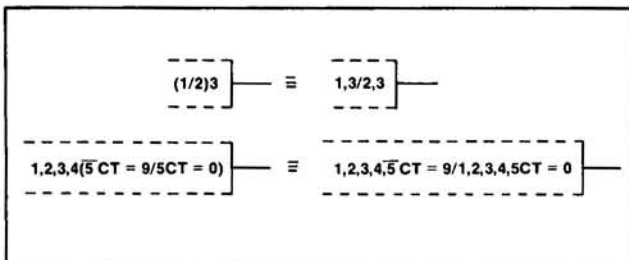

Figure 8-35. Factoring Output Labels

8-151. THEORY OF OPERATION

8-152. Overall Counter Operation

8-153. Refer to *Figure 8-36* HP 5384A/HP 5385A Block Diagram for the following general description.

8-154. On the A1 motherboard there are two input channels that condition and shape the input signals.

8-155. In channel A of the HP 5384A and HP 5385A, the signal may be attenuated by a X20 attenuator (ATTN) or filtered by a 100 KHz low pass filter (LPF). The trigger level is automatically centered at the average signal level of the input signal or the trigger level may be manually set. The conditioned signal is then input to the Multiple Register Counter (MRC) A1U1.

8-156. Channel B of the HP 5384A has an automatic gain control amplifier in the input circuit that also provides a manual attenuator function. The AGC/Manual Attenuator circuit is followed by a divide by 4 circuit. The conditioned signal is then input to the MRC.

8-157. Channel B of the HP 5385A has a PIN attenuator in the input as well as an automatic gain control amplifier. The signal is routed through a divide by 256 circuit then input to the MRC.

8-158. The MRC receives the input signals from channel A and B. Under the control of the 3870 microcomputer (A1U2), the MRC processes the data for the function specified by the function switches.

8-159. To make measurements, the 3870 routinely scans and stores the position of the function switches and then configures the MRC to the desired measurement mode. The 3870 then "arms" the MRC, which allows the measurement to begin. The input signal to the MRC starts the measurement, and when the Gate-Time determined by the microcomputer has elapsed, the next input signal pulse completes the measurement. The 3870 will then read the measurement data from the MRC, manipulate it mathematically and directs it to the display assembly (A2). The display assembly receives, decodes, and displays the data. The exponent, exponent sign, units designators and decimal point are computed within the 3870 at the same time as the measurement data. The 3870 will continue to repeat the measurement cycle, until the switches are changed.

8-160. For increased measurement accuracy, a Temperature Compensated Crystal Oscillator (standard for the HP 5385A, Option 001 for the HP 5384A), or Oven Oscillator (Option 004) may be used in place of the standard reference oscillator. An external 10 MHz time base may also be used as a reference oscillator.

8-161. In digital frequency counters, there is always a possible error of ± 1 count. For increased measurement resolution in the HP 5384A/HP 5385A, an interpolator circuit is used. An interpolator circuit measures the possible time difference between the opening and closing of the counting gate and clock pulses from the internal time base. If the counting gate does not open at the same time a clock pulse occurs and close at the same time a clock pulse occurs (n number of events later), a difference occurs. The difference is measured and the information is sent to the microcomputer and used in calculating the input frequency, eliminating the ± 1 count uncertainty.

8-162. For remote control, either HP-IL (A4 board) or HP-IB (A5 board) is used. Both boards make use of a 3870 microcomputer to communicate with the 3870 and the MRC on the A1 motherboard. The input/output (I/O) interface assembly contains the bus transceivers, address switches, and buffers. The A4 or A5 I/O assembly interfaces directly to the cable connectors on the rear panel of the instrument.

8-163. The built-in power supply is a variable pulse width, switching supply. The greater the duty cycle of

the pulse width, the higher the output power. The supply is regulated for +5 volts out. External DC input power of 9-15V and the 6V power from the optional battery pack is also regulated to +5 volts. The output of the power supply is protected by a crowbar circuit and a 2 amp fuse. If either the input or the output voltage from the supplies goes too high, the crowbar circuit latches on and causes the fuse to open. The blown fuse protects the rest of the circuitry from the excessive voltage.

8-164. The optional battery pack assembly has a battery charger (A3 board) for automatic recharging of the battery whenever external power is connected. External dc of 9-15V or unregulated 13.5 Vdc from the mains input supply is regulated to charge the lead acid battery.

8-165. The function select keys on the front panel keyboard (A2) select functions by sending a command to the microcomputer (A1U2) when pressed. The microcomputer responds by configuring the MRC (A1U1) to perform a function according to which key on the front panel has been pressed.

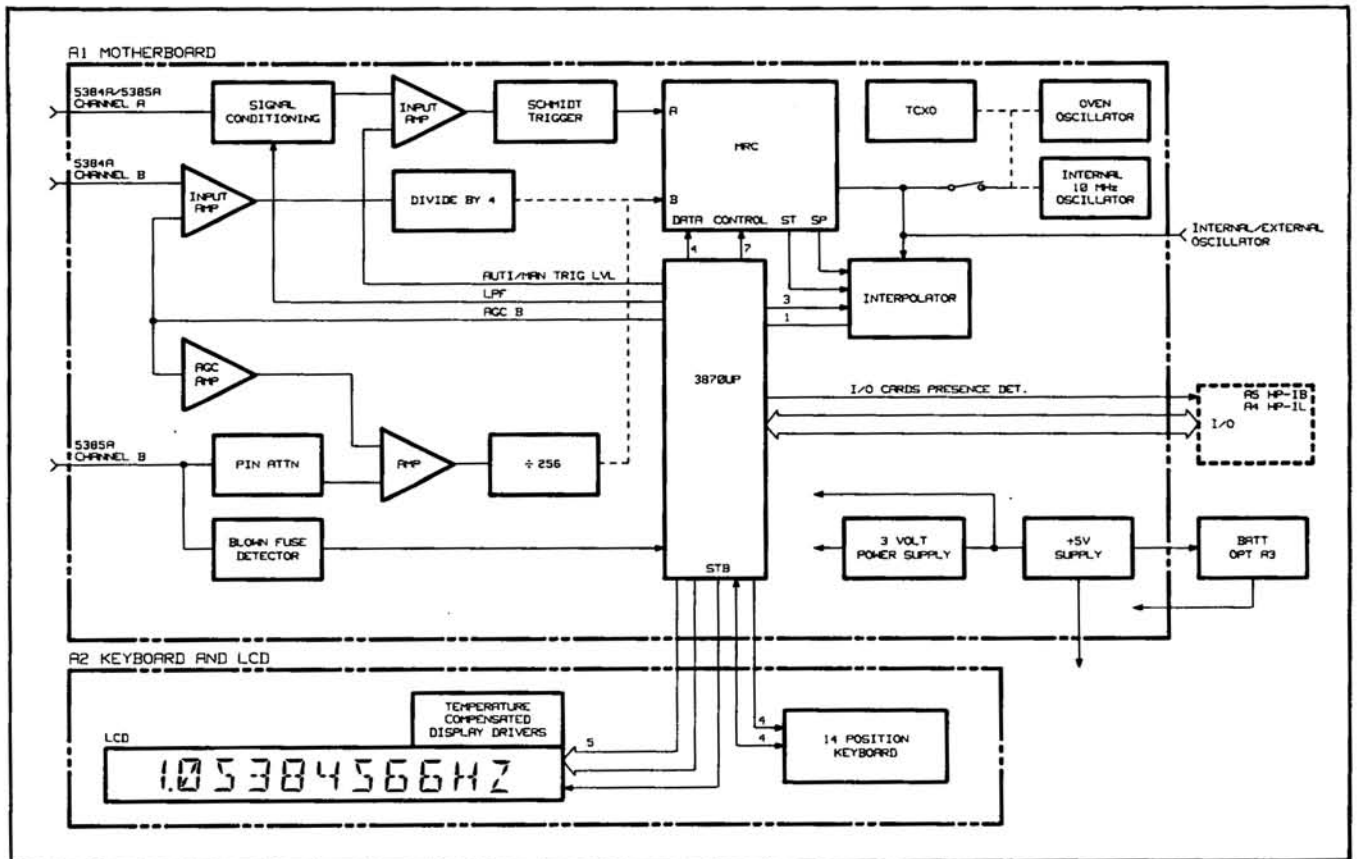

Figure 8-36. HP 5384A/HP 5385A Block Diagram

8-166. The 12-character, 14-segment Liquid Crystal Display (LCD) contains built-in temperature compensated display drivers. The display shows the results of frequency or period calculations made by the micro-computer. The display information is updated a maximum of four times per second.

8-167. SIGNAL DESCRIPTIONS

8-168. *Table 8-6* is a list of the signals used in the HP 5384A and HP 5385A. The list is in alphabetical order and includes the mnemonics for cross-reference with the schematic diagrams. A description of the function of each signal is included in the table.

Table 8-6. Signal Descriptions

MNEMONIC	DESCRIPTION
CS	Chip Select Enable line. When enabled, allows the ROM to respond to its addresses.
DAV	Data valid line. One of the three lines used in the handshake. The line is controlled by the data source.
DIR	Determines the direction of data flow between the motherboard micro-computer and the I/O microcomputer.
DREC	Data Received line between the two microcomputers.
DVAL	Data Valid line.
EOI	End or Identify. Indicates the last data byte of a multibyte sequence; also used with ATN (attention) to parallel poll devices for their status bit.
EXT/INT	External Interrupt is pulsed by the HP-IL chip when the HP-IL chip needs servicing by the microcomputer.
INA	Data line for the display.
ISA	Instruction line for the display.
MR	Reset for the interpolator counter.
NDAC	Not Data Accepted line. One of the three handshake lines. The line is controlled by the device (s) receiving data.
NDACEN	Not Data Accepted Enable. The line determines whether the microcomputer or the ATN line will control the NDAC line.
NRF	Not Ready for Data line. One of three handshake lines.
PATT	Pattern is used for generating test patterns on lines. The line is controlled by the device (s) receiving data.
PWO	Enable line for the display.
RD	Read Data. The HP-IL chip will output data on the data lines to the microcomputer.

Table 8-6. Signal Descriptions (Continued)

NEMONIC	DESCRIPTION
RG0	Register Control Select line.
RG1	Register Control Select line.
RS	Register Select. Controls which register data will be read from or written to.
RXD0	Receive Data.
SENSE	I/O Board Detector line.
SI	Serial Input line.
S/L	Shift Load. Data is loaded into the register when the line goes from high to low.
S/R	Send not Receive. These are direction control lines. TA is
SRQ	Service Request. The line is used to indicate a need for attention and can act as an interrupt of the current sequence of events.
STB	Strobe for display clocking.
ST/SP/CLK	Signature Analysis controls only.
SYNC	Synchronizing line for the display.
TA	Talk Addressed. This line controls the direction of data flow through the data and handshake buffers.
TEST	Mostek's own internal manufacturing test. Do not use.
TEST	A self test function that allows the HP-IL I/O card to operate outside of an instrument.
TXD0	Transmit Data.
Write	Write to the HP-IL chip. This line indicates the direction of data flow and indicates data is valid.

8-169. Detailed Theory of Operation

8-170. Use *Figure 8-50*, HP 5384A A1 Motherboard Assembly for reference for circuit description of the HP 5384A and HP 5385A input Channel A.

8-171. A signal is applied through input connector J1 and dc blocking capacitor C1. The signal passes through a frequency compensated attenuator. The attenuator is made up of R3, R4, R5 and C2, C3. Relay K1 selects the circuitry for either X1 or X20 attenuation. In X1 attenuation, the signal is divided by R3, R5 and C2, and pins 14 and 8 of K1, to Q2. In X20 attenuation, the signal flows through R3, (with high frequency impedance compensation through C2 and R4) then through Pin 8 and Pin 1 of K1. The signal continues from K1 Pin 1 through R5 and C3 to ground. Relay K1

is powered by Q1. Q1 is used as a switch and is controlled by an active low level from the microcomputer. CR1 is used to protect Q1 from voltage spikes generated by the collapsing magnetic field around the winding of K1.

8-172. The limiter circuit CR2 and CR3 together with R2, R3, R4 and C2 form an input protection circuit.

8-173. The high input impedance is converted to a low impedance by Q2 and Q3 connected together as a unity gain buffer.

8-174. A 100 kHz low pass filter (LPF) can be inserted into the signal path between the output of the impedance converter and the input of the first gain stage U3A. The filter is a single pole filter with series resistor R10 and shunt capacitor C8 connected to ground through Q5. The filter is turned off by applying a TTL low signal from the microcomputer to the base of Q5. Q5 turns off causing the collector to go high which turns on Q4. When Q4 turns on, an ac path through C6 and Q4 is created.

8-175. The first gain stage U3A is a differential line receiver with the signal applied to pin 10. A manually adjustable dc bias voltage (controlled by MANUAL TRIG A/MANUAL ATTN B, R1) or a preset bias level (set by R43) is applied to the other input (pin 9). At power-up, the preset bias level is on the input at pin 9. To switch to manual adjustment and activate the front panel MANUAL TRIG A/MANUAL ATTN B control, a TTL high is placed on pins 9, 10, and 11 of analog switch U16. The TTL low, labeled "AGC" on the schematic, is generated by the microcomputer when the MAN LEVEL key on the front panel is pressed.

8-176. The first gain stage U3A is connected to U3B as a differential amplifier. U3C is a Schmitt trigger with the positive feedback provided by R18B. C11 and C12 provide frequency peaking to compensate for the roll off caused by the input buffer. Transistor array U6B is connected as a differential amplifier to drive the A channel input of the MRC (U1).

8-177. HP 5384A Channel B

8-178. A signal is applied through the input connector J2 and dc blocking capacitor C14 and through C19 to pin 13 of U4B. Signal attenuation is achieved either manually or through an automatic gain circuit (AGC).

8-179. Signal attenuation through AGC is activated by the microcomputer outputting a high on pin 9, 10,

and 11 of the analog switch U16 (MAN LEVEL key is turned off). The high on U16 pins 9, 10, and 11 causes R22 to be connected to the base of Q7. Q7 turns on, grounding the anode side of the PIN diode CR5, thereby removing manual control of input attenuation. The PIN diode CR5, has a high impedance at low current levels so small signals pass through C19 to pin 13 of U4B unattenuated. However, as the input signal increases, attenuation begins with Schottky diode CR4 limiting the positive half of the input signal to approximately .6 volts. As the input signal becomes larger, the average dc level becomes more negative. The negative potential is also present at the cathode of PIN CR5. Since PIN diode CR5 cannot switch as fast as CR4, CR5 responds to the negative dc by functioning as a resistor. CR5 conducts more current as the dc potential across the diode increases. With increased current through CR5, the resistance of CR5 decreases, forming a signal voltage divider with R25. The resistance of the PIN diode is a function of its forward current and will be approximately 10 ohms with a 5V rms input signal. This causes an attenuation of about 15 dB.

8-180. When manual control of attenuation is desired, the MAN LEVEL key is pressed which gives instructions to the microcomputer. The microcomputer responds by placing a low on the AGC line to pins 9, 10, and 11 on U16. U16 connects a ground to the base of Q7 which is then is turned off. With Q7 turned off, current from the emitter follower Q6 flows through CR5 to control the resistance of CR5. The front panel control R1 (MANUAL ATTN LEVEL B) varies the voltage on the base of Q6 which in turn varies the current through CR5 from 0 to about 10 mA. CR5, CR6 and CR7 serve as an input protection network.

8-181. After attenuation, the input signal is applied to pin 13 of U4B, a differential line receiver. The other input, pin 12, is connected to an offset adjustment, R32 which is used to maximize gain by centering the negative of positive going pulses in the center of the amplification range of U4b. The next gain stage, U4A is configured with negative feedback through R40. C15 is used for high frequency peaking. A dual master slave flip flop (U5) is connected as a divide-by-four frequency divider. The first divider also acts as a Schmitt trigger and provides some gain. Transistor array U6A is connected as a level shifter to drive the B channel input of the MRC.

8-182. HP 5385A Channel B

8-183. In *Figure 8-51*, input channel B of the HP 5385A has a fuse in the input BNC connector. When the fuse opens, an error message appears on the display of the counter. A Fuse Blown Detector is used to send the information to the microcomputer. A dc current is passed through R31, R66, L3 and the fuse to ground. If the fuse is open, the voltage will rise on pin 13 of U18A which causes a high output on U18A. The high output instructs the microcomputer to output a message on the display of the counter.

8-184. In the input attenuation circuit, there is a constant voltage across zener diode CR30. The current path from CR30 flows through R26, CR4 and CR5, CR7 and R27 to ground. A second current path sourced from pin 8 of U18B flows through CR6 and also through R27 to ground. With a small input signal the voltage on the anode is high enough to force enough current through CR6 to drop the diode resistance. With low resistance through CR6 low level input signals pass through to U4 pin 1. Also, with low resistance on CR6, less voltage is dropped across it so the voltage across R27 to ground is higher. The higher voltage at R27 means less voltage drop across CR4, 5 and 7, so less current passes through them. With less current through the diodes their resistance is high, therefore input signals are steered toward CR6.

8-185. The limiter consists of CR24 and CR25. They are a pair of back to back diodes that turn on when the signal is about 1.5V or greater.

8-186. The input amplifier consists of three stages; U4, U5 and U16. Together they provide approximately 20 dB of gain from 90 MHz to 1 GHz.

8-187. The signal passes through C62 and goes to the 1/256 frequency divider (U19, pin 10) and the signal detector (CR29) (the AGC feedback path). When there is no input signal present, the frequency divider oscillates at about 950 MHz. With a signal present, the output is 1/256th of the input frequency.

8-188. In the signal detector, the detector diode CR29 is biased by a temperature compensated dc reference voltage. The dc voltage reference is obtained from between R97, CR26, R35 and R33. The signal goes through C63 to the detector diode CR29 and blocked by L15. The signal is rectified by CR29 and filtered to a dc level by C64. The filtered dc level adds to and raises the dc bias level on the cathode of CR29. The detector is adjusted by R34 for the proper detection level.

8-189. The feedback is routed through U17A, U18D and U18B. A high feedback level causes the output voltage on pin 8 of U18B to drop. When the voltage drops the current through CR6 drops, thereby increasing the resistance of CR6 and attenuating the signal passing through. With more voltage dropped across CR6, less voltage is dropped across R27. Therefore the voltage across CR4, 5 and 7 is increased. The increased voltage causes an increase in current flow through the diodes. The increased current decreases the diode's resistance, thereby conducting more signal to ground through C16. R23 and R24 help maintain 50 ohms input impedance.

8-190. The feedback is then passed through a switch U17C to amplifier U18D (pin 2). Trigger circuit U18D is used so that noise will not activate the amplifier U18B.

8-191. The manual level/AGC switch U17, changes the input of the AGC Amplifier from the detected voltage to the manually controlled voltage. U17 switches when the microcomputer sends a low to pins 9, 10, and 11 of U17.

8-192. The AGC amplifier U18B, completes the feedback path to the attenuator. U18B amplifies the reference voltage from U18D or the manual setting, depending on the setting of U17.

8-193. 3870 Microcomputer

8-194. The 3870 microcomputer U2, runs at an internal clock rate of approximately 3.5 MHz as set by L4. It continually cycles through programmed routines, which are stored in ROM within the IC. The block of front panel switches are routinely polled via the Switch Status bus and the status is stored in internal RAM. Any change in the status is detected and verified. A new function switch contact must remain stable for 32 scans to be accepted.

8-195. The 3870 controls the operation of the MRC via the Address/Control bus. Address lines RG0 and RG1 select one of four internal registers of the MRC. NS0, NS1, and NS2 are nibble select lines (nibble = 4 bits) which address data within the various registers.

8-196. Command line R/W (Read/Write) controls the direction of data transfer on the bidirectional Data/Control Bus.

8-197. The Data/Strobe bus contains four bidirectional data lines, D0-D3, and the command line STR. STR indicates an address or command is valid.

8-198. The Multiple Register Counter (MRC), a counter on a chip, is an LSI bipolar IC utilizing both EFL and I²L circuitry. The reference oscillator drives the MRC via pin 21. The reference oscillator may be monitored at TP3 located on the A1 Motherboard. Inputs from channels A and B are fed into the MRC at pins 30 and 28 respectively.

8-199. Within the MRC are four addressable registers. The Events Register and Time Register are counting registers; thus they are Read Only. The Status Register monitors the operation of the MRC, and the Control Register receives the commands from the 3870 and determines the MRC's configuration.

8-200. Interpolator Technique

8-201. A major feature of the HP 5384A and HP 5385A is the pulse count interpolators.

8-202. Without interpolators, the gate signal during a measurement would normally be synchronous with

the main clock (time base). The slight time difference between the actual events of channel A triggering, and the opening and closing of the gate, would represent an unrecoverable error factor, limiting the accuracy of the measurement. The start and stop interpolators within the counter provide a method of determining the amount of time difference for both start and stop events. Refer to *Figure 8-37*.

8-203. The MRC provides start and stop interpolator pulses, representing the time difference (error factor) between channel A trigger events and the time base. A dual slope integration scheme is used. Basically, a short 100 ns interpolation pulse, from the MRC, is used to rapidly charge a capacitor via a constant current source. When the pulse ends, the capacitor begins a scaled discharge at about 1/200th of the charge rate. This proportionally expands the interpolator error pulse by a factor of 200. This integrated waveshape is then squared and used to gate a time base signal into the interpolator counter. The count in the counter will proportionally reflect the length of the interpolator pulse. Refer to *Figure 8-38*.

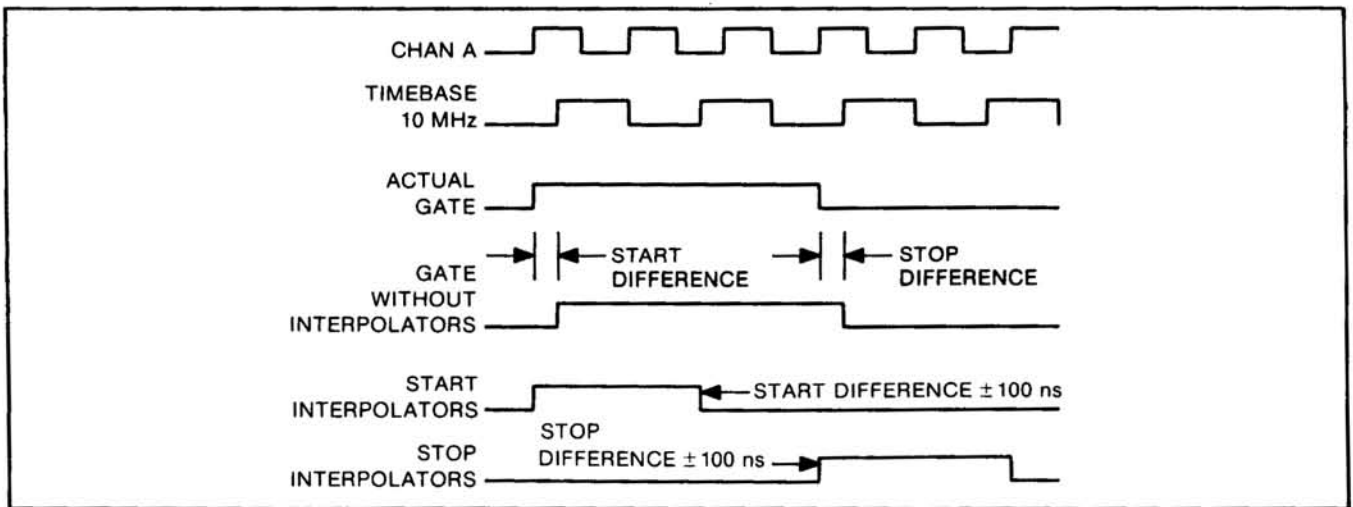

Figure 8-37. Interpolator Timing Diagram

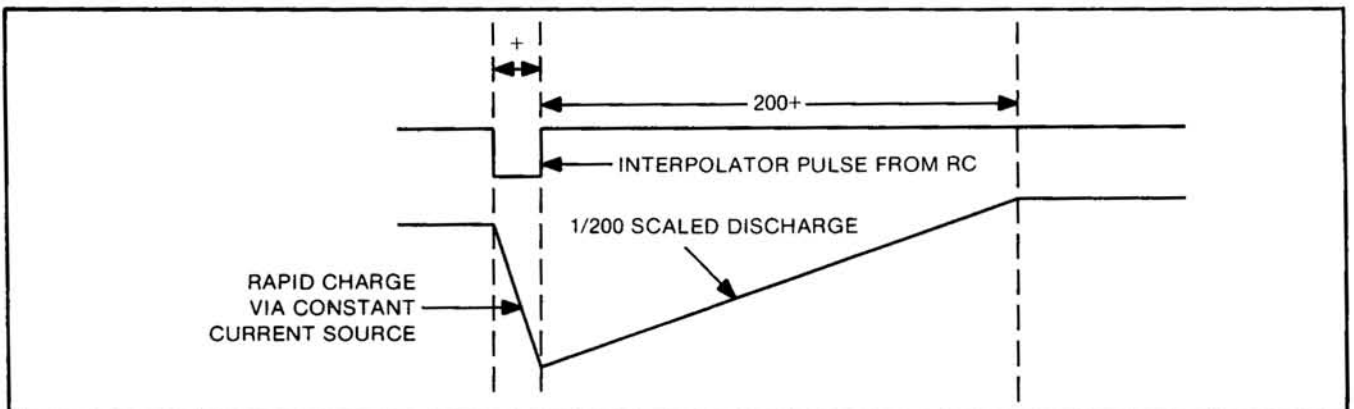

Figure 8-38. Expanded Interpolator Error Pulse

8-204. To convert the count in the interpolator to real nanoseconds, the MRC provides two calibration pulses; a short calibration pulse of 100 ns and a long calibration pulse of 200 ns. By inputting each of these known length pulses into the same integrator and noting the number of counts produced, a mathematical proportion is established, with which the true time for any pulse length can be interpolated. For example, if the short (100 ns) calibration pulse produced 200 counts, and the long (200 ns) calibration pulse produced 400 counts, a pulse of 150 ns would produce 300 counts. Inversely, if 300 was the number of counts accumulated during the interpolator pulse integrator cycle, then the error factor would be 150 ns. Refer to Figure 8-39.

8-205. The final equation for determining the actual gate time is:

$$\text{MEASUREMENT TIME} = (\text{counts in T-register}) \times 100 \text{ ns}$$

$$+ \frac{\text{Count X-Count S}}{\text{Count L-Count S}} \times 100 \text{ ns}$$

(for the Start Interpolator)

$$- \frac{\text{Count X-Count S}}{\text{Count L-Count S}} \times 100 \text{ ns}$$

(for the Stop Interpolator)

where:

- Count X = effective counts from interpolation pulse
- Count S = effective counts from short calibration pulse
- Count L = effective counts from long calibration pulse

For example, given the following values:

Count in MRC T register	= 10
Count from Start Interpolator	= 100 (+256)
Count from Stop Interpolator	= 230
Count from short calibration pulse	= 200
Count from long calibration pulse	= 150 (+256)

$$\text{GATE TIME} = (10 \times 100 \text{ ns}) + \frac{356-200}{406-200} \times 100 \text{ ns} - \frac{230-200}{406-200} \times 100 \text{ ns}$$

$$= 1000 \text{ ns} + 75.7 \text{ ns} - 14.6 \text{ ns} = 1061.1 \text{ ns}$$

8-206. The general measurement program routing is to make a measurement, read the MRC registers, read the interpolator counters, perform the calculations, and display the results. In between measurements, the MRC registers and the interpolator counters are reset.

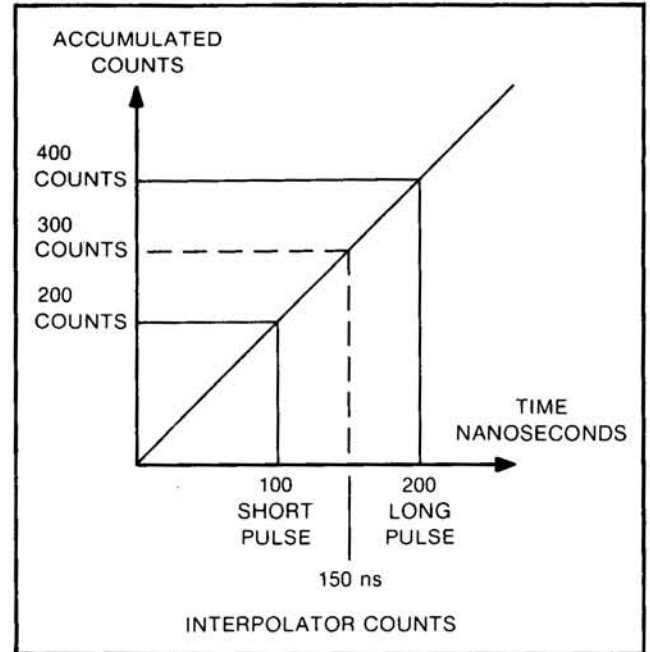

Figure 8-39. Short and Long Calibration Pulses Example

8-207. HP-IB

8-208. The HP-IB, A5 board of the HP 5384A and HP 5385A counters (Figure 8-52) consists of two line transceivers (U1 and U2), a quad nand gate (U4) and a 3870 microcomputer (U5), and a few other discrete components.

8-209. The line transceiver ICs are bidirectional buffer amplifiers. Each transceiver buffers 8 of the 16 data lines used in HP-IB. (Eight lines are used as a data bus for information transfer, 5 lines for general bus management, and three lines for the handshake sequence.) Direction of data flow is controlled by disabling the undesired direction buffer. The buffers are controlled by TTL logic level inputs to U1(4, 8, 11, 17) and U2(17). A logic high on these pins causes data to be transmitted onto the interface bus. A logic low causes data to be received from the interface bus. The transceivers are switched by U3.

8-210. U3 also pulls the NDAC line low to start the handshake for the information which is sent by the controller with the line true (0).

8-211. The latch (U4) receives short pulses from the Remote Enable (REN) and the Interface Clear (IFC) lines and holds the information until the software in the microcomputer reads them.

8-212. The HP-IB microcomputer (U5) receives commands from the bus, interprets them, and sends them to the motherboard. It also receives measurement data from the motherboard, formats it, and sends it out on the bus when addressed to talk. The bus protocol that performs these tasks is generated by instructions contained in the program ROM of the microcomputer.

8-213. HP-IL

8-214. Refer to the HP-IL schematic diagram, *Figure 8-53*, for the discussion of the HP-IL theory of operation.

8-215. The HP-IL, A4 board of the HP 5384A and HP 5385A counters consists of transceiver pulse transformers (T1), electrostatic discharge (ESD) protection diodes (CR1-4), an HP-IL IC (U1), a microcomputer (U2), and a few other discrete components.

8-216. The signals from the loop come into the Schmitt trigger receiver inputs (RXD0 and RXD1) of the HP-IL IC (U1) through a small pulse transformer which provides a net voltage step-up and loop isolation. Zener diodes CR1 and CR2 provide Electrostatic Discharge protection. Resistors R1 and R3 to ground from the receiver inputs provide the proper load for the loop.

8-217. The transmitter outputs (TXD0 and TXD1) send a signal through a simple low-pass filter and impedance matching network consisting of capacitors C2 and C3, and series resistors R2 and R4. Zener diodes CR3 and CR4 are for electrostatic discharge protection. The signal goes to a pulse transformer which steps down the voltage to the proper loop level and provides isolation.

8-218. The HP-IL IC (U1), accepts serial data (a message frame) from the loop, through the input buffer. The message frame is gated into the input register. Most of the frame decoding is done in the input register. Depending on the type of frame, the message frame may be immediately sent out again through the input register multiplexer and the transmit encoder or, it could be loaded into R2-R of the microcomputer on data lines D0 through D7. R2-R is the read only half of register number two of eight registers contained in the microcomputer. The registers are the microcomputer's main means of communication with the data bus. The address code is sent on lines RS0 through RS2 of the microcomputer.

8-219. The microcomputer (U2) communicates with the main microcomputer in the counter through four data lines (D0 through D3) and three handshake lines (DIR, DVAL, and DREC). DIR is driven only by U2 while the other are may be driven by either U2 or the main microcomputer in the counter. Whenever there is a simultaneous request for data transfer by both microcomputers, the I/O microcomputer U2 will have precedence.

8-220. The handshake lines are used to coordinate the transfer of data between U2 and the main microcomputer in the counter. DIR signals the direction of data flow; low logic level for data transmission from U2 to the main microcomputer and logic high for data flow from the main microcomputer to U2. The DIR line is also used for aborting data transmissions from the main microcomputer to U2 on the A4 interface board. Aborting transmission is accomplished by the interface driving the DIR line low instead of the DREC line after it receives the last nibble of data addressed to it. The DVAL line signals that data is valid. DVAL also signals a request for data transmission from the main microcomputer on the A1 board.

8-221. Inputs XTL1 and XTL2 interface an LC network to set the internal oscillator frequency of the microcomputer. The frequency is approximately 3.5 MHz.

8-222. Pins 8 through 14 (port 4) connect to switch S1 and are used to set the address of the counter.

8-223. The RESET is an active low input that is used to reset the internal state of the microcomputer.

8-224. The EXT INT input is an external interrupt. The input is also used in conjunction with the timer for event counting.

8-225. The STROBE provides a single active low output pulse after valid data is present on port 0 (0-0 – 0-7) during an output instruction.

8-226. The HP-IL system uses a three-level code in which information is encoded as a function of signal level transitions. All information on the loop is sent as a sequence of eleven bits called a message frame. See *Figure 8-40*. The first bit, called the sync bit, is coded in a special way so that each device can easily recognize the beginning of a frame. The sync bit and the next two bits are called control bits and they determine the major classification of a message. Command messages, ready messages, and data messages are examples of the major classes. The remaining eight bits, sometimes called data bits (not to be confused with the data

message) specify the particular message within the classification. The Unlisten command frame, for example, would be 100 0011111, while the Interface Clear command is 100 10010000. The Send Data ready message is 101 01100000. The space between the control and data bits is for clarity only and does not represent a time delay or any other delimiter.

8-227. The electrical connection from one instrument to the next is a differential, voltage-mode, two-wire, 100 ohm balanced line. Both wires are floating with respect to the ground connections of the instruments. One of the wires is chosen as a reference and the voltage of the other wire is measured only with respect to the reference. This has several advantages. Device grounds need not be at the same potential. In fact there can be rather large differences with no effect. HP-IL avoids the problem of ground loops in an interface system. Since noise pulses tend to affect both wires equally, the balanced nature of HP-IL

strongly rejects these pulses. The same holds true for noise radiation from the system itself. As one wire's voltage rises the other's falls, tending to cancel any radiated signal.

8-228. Bits are encoded using a three level, or bipolar code. The voltage difference between the two wires may be nominally -1.5 Volts, 0 Volts, or +1.5 Volts. A logical one is encoded as a high pulse (+1.5 Volts) followed by a low pulse (-1.5 Volts). A logical zero is a low followed by a high. A logical one sync is a high, low, high, low sequence. A zero sync is low, high, low, high. The nominal pulse width is one microsecond and each bit sequence is always followed by a minimum delay time (0 Volts) of about two microseconds. Refer to Figure 8-41. This type of code provides good noise immunity, is relatively insensitive to speed variations, is self-clocking, and has no dc component in the signal. Figure 8-42 shows the waveform specifications. The dashed line illustrates a typical waveform.

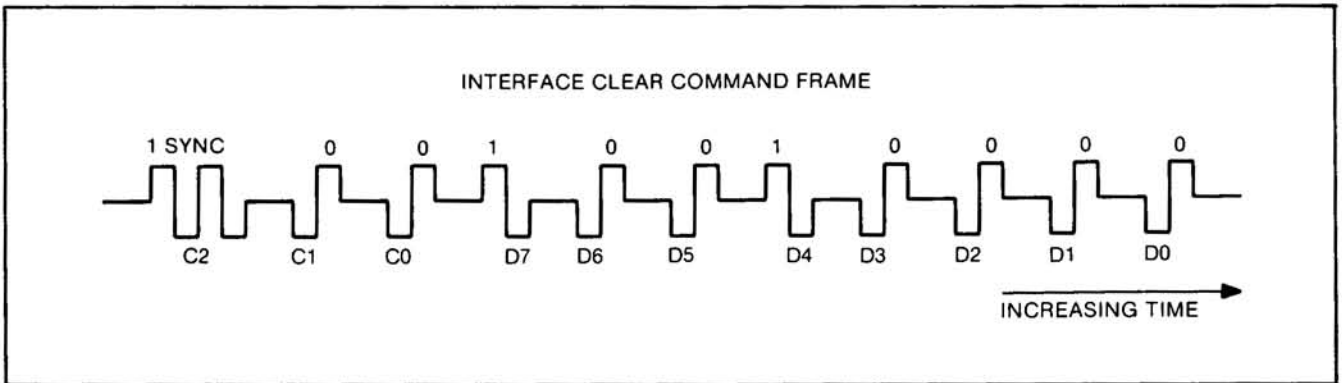

Figure 8-40. Sample HP-IL Frame

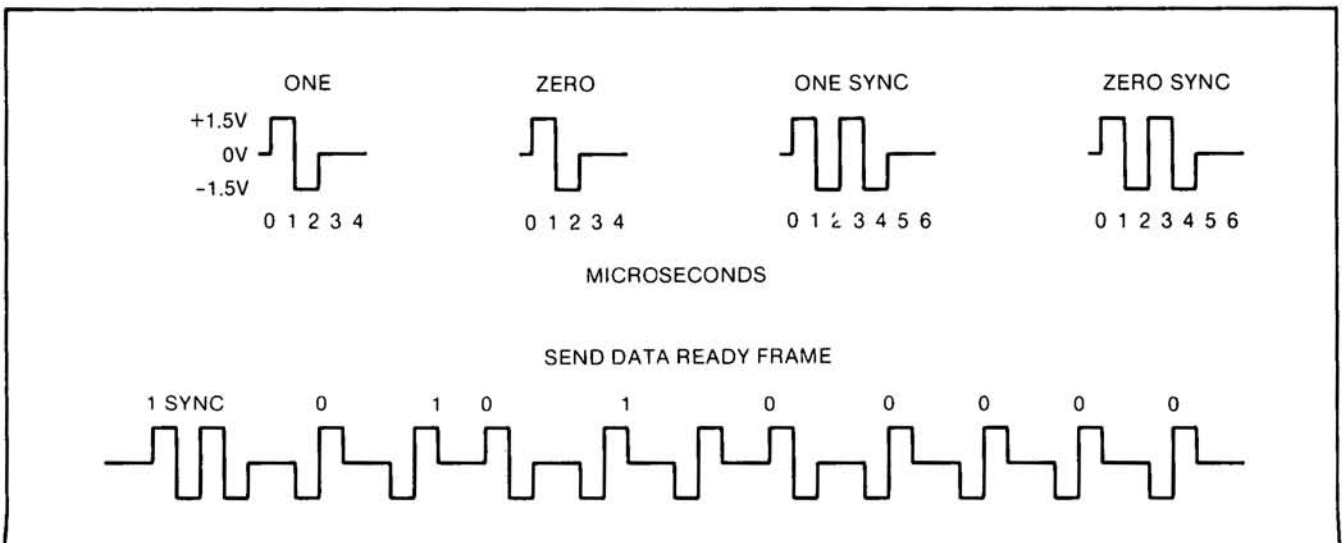

Figure 8-41. HP-IL Bit Encoding

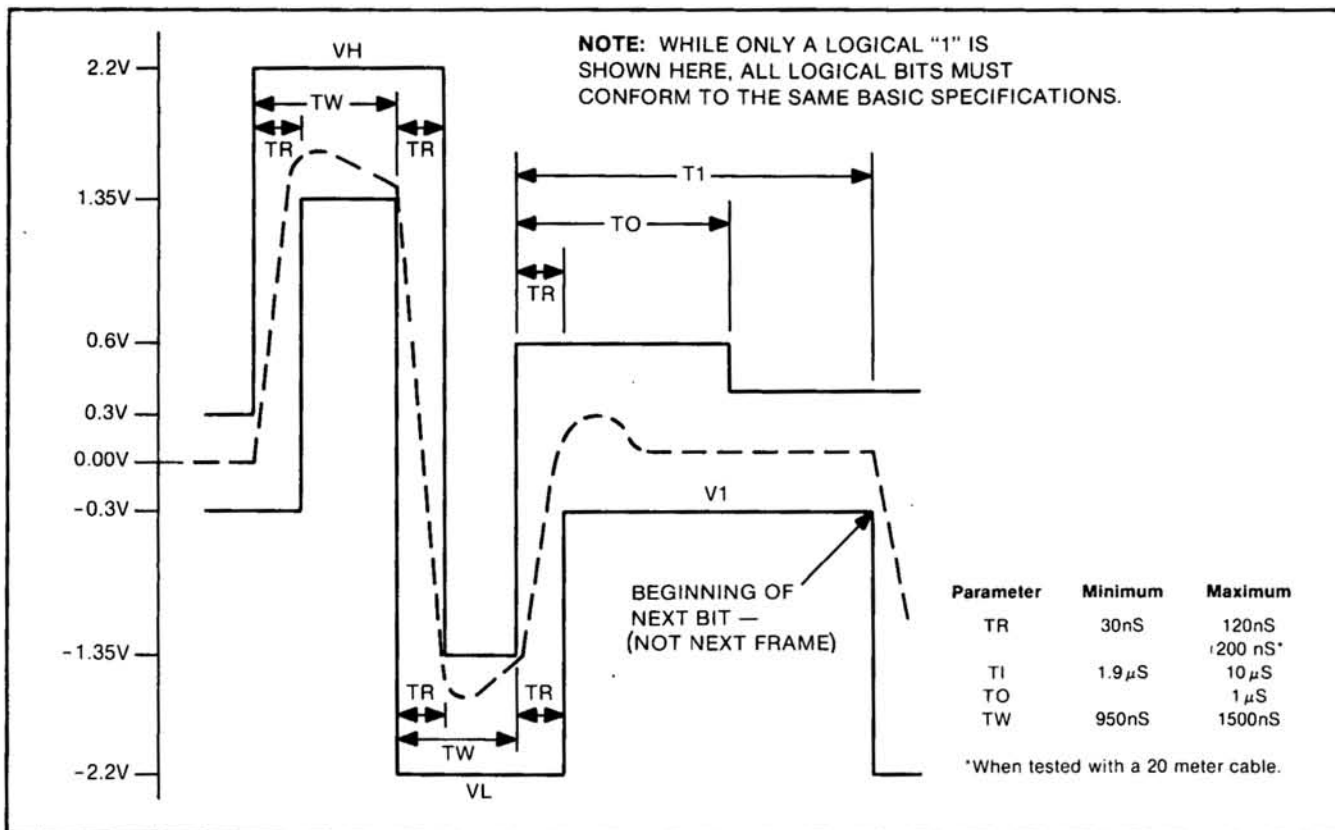

Figure 8-42. Open Circuit Output Waveform

8-229. Frames are asynchronous with respect to each other. That means no common system clock is necessary in HP-IL. The sync bit requires six microseconds to transmit while other bits take four microseconds. A complete frame, which may contain one byte of data, takes 46 microseconds assuming no extra delay between bits. If we further assume no extra delay between frames, a maximum loop rate of approximately 20 kilobytes per second could be achieved. In a typical application, hardware and software delays lower this rate to somewhere between three and five kilobytes per second.

8-230. POWER SUPPLY

8-231. Refer to Figures 8-50 or 8-51 (sheet 2 of 2), A1 Motherboard Power Supply Assembly for the following discussion on the theory of operation.

8-232. The HP 5384A and HP 5385A power supply is a dc to dc converter having a constant frequency, variable pulse width modulator. There are three sources of raw power available; ac line, external dc and a 6-volt internal battery. Although only one of the sources is necessary to power the instrument, any or all may be connected.

8-233. In the dc to dc down converter type power supply, power is pulsed into an output filter that smooths the large pulses into very small changes that are acceptable and can be called dc. By modifying the ratio of on to off time of the switch transistor, (pulse width modulation) the output voltage can be adjusted.

8-234. When the switch transistor is saturated, current ramps up in L1. Some of the energy is dissipated in the load, and some energy is stored in the magnetic field of L1 and the electric field of C36 and C69. When the switch transistor turns off, the magnetic field around L1 collapses and transfers the energy in L1 to the load and filter capacitor via CR12.

8-235. Power is applied to the primary of T1 through noise filter L7 (and L6 in the return line). Fuse F1 is a 1/4 amp slow blow fuse mounted inside the counter and is intended to blow only in the case of catastrophic failure of the transformer T1 or bridge rectifier CR8. All other failures should result in the 2 amp fast blow fuse F2 opening. The 2 amp fuse is accessible from the rear panel.

8-236. External dc polarity protection and shorting protection is provided.

8-237. The ON/STBY switch connects the power supply and battery to the counter circuitry. The switch is a make before break type which connects the minimum load R61 to the power supply before the instrument load is disconnected (the counter switched to standby).

8-238. A minimum load is connected to the power supply at all times. The oven oscillator option replaces R61 as the minimum load. You may disconnect the battery from the circuit to save battery power, in which case the battery will charge only and the charger becomes the minimum load.

8-239. The rectified output of CR8 goes to C29 and C30, two 2200 ufd capacitors that have a low series impedance and serve as the power supply filter.

8-240. To protect the counter circuitry from over-voltage, a crowbar circuit will fire and cause F2 to blow. The crowbar circuit is formed by series resistor R50 and SCR CR9, Zener diodes CR10 and CR13, and low pass filter C28. The voltage on C29 and C30 is monitored by CR10 and the power supply output voltage of Q10 is monitored by CR13. The capacitor C28 shorts noise spikes to ground so they do not cause the SCR to fire.

8-241. Zener diodes CR10 and CR13 are connected together in a discrete, wired OR configuration. The SCR will fire if the voltage on the filter capacitors rises to approximately 20 volts or if the power supply output voltage rises to approximately 6.5 volts.

8-242. Once the SCR fires, it latches and causes the fast blow fuse, F2 to open. The crowbar circuit is intended primarily for protection against external dc over-voltage applied by the user or shorting of the switching transistor Q10.

8-243. The 5 volt regulator U7 provides power to switching regulator U9 and the switching transistor driver Q11. U8 outputs a 2.5 volt reference to U9. U9 uses the 2.5 volts for a reference to regulate the power supply output voltage over temperature with no adjustments required. U8 is connected to the reference input of U9 (pin 2).

8-244. Inside the U9 regulator is an oscillator operating at 87 kHz, a comparator, and an error amplifier. The oscillator is used to generate a ramp signal that is input to the comparator. The error voltage from L1 is fed through the voltage divider R62 and R63, into the inverting amplifier and comparator of U9. When the amplified error signal is greater than the oscillator ramp level, the comparator output (pins 11 and 14)

turns on the switching transistor Q10 raising the output voltage. If the amplified error signal is below the oscillator ramp level the comparator commands Q10 to turn off.

8-245. To insure that Q10 saturates to within .1 volts of the input voltage, a pulse of constant current is drawn from the base of Q10 by the constant current pulse driver Q11 and Q12. The constant current pulse driver circuitry consists of Q11, Q12, R59 and R60. Normal operation produces pulses of .6 to .7 volts across R60. The pulses are driven by pins 11 and 14 of U9.

8-246. BATTERY PACK CHARGER

8-247. Refer to *Figure 8-54*, A3 Battery Pack for the following discussion on the theory of operation.

8-248. The battery charger board performs two major functions: 1). It recharges the battery when low and, 2). It delays damaging battery discharge by turning off the dc to dc converter in the power supply on the motherboard.

8-249. The battery charger is a two step current charger (hysteresis loop charger). A constant current of 10 mA is always applied to the battery whenever external power is applied to the instrument. The charge rate is stepped up to approximately 500 mA if the voltage conditions of the battery indicate re-charging is needed and the STBY/ON switch is in STBY.

8-250. The battery low indicator goes active when approximately 20 minutes of operation remain. When the voltage sensed at the dc to dc converter input is too low for reliable operation, the disabling comparator circuitry goes active and shuts down the dc to dc converter on the counter motherboard. This reduces the battery drain to less than 50 mA. The counter can remain in this state for 24 hours before battery damage occurs.



The battery can be permanently damaged if the counter remains in the power down state for more than a day. To prevent damage, switch counters to STBY and recharge as soon as possible.

NOTE

For maximum battery life, keep the battery fully charged as much as possible (connected to an external power source) when not in portable operation.

8-251. Transistors Q1E and Q1D, and R10 and R15 form a 10 mA constant current source. The current source is fed through CR8 in a wired-OR configuration. This trickle charger always sources 10 mA of current to the 6-volt sealed lead acid battery when external power is applied to the counter.

8-252. The Op Amp U2B and associated resistors form a closed loop constant current charger of approximately 500 mA. The resistor R1 (.05 ohms) is the current sense resistor providing the current to voltage conversion for feed back in the loop. The 500 mA charger is turned on and off by the charge control circuit through diode CR4.

8-253. When the counter is switched into the ON position, the charger may be disabled independently of the charge control circuit by injecting current through CR1. When the instrument is in Standby, the charge control circuit will command the 500 mA current source to be on if the battery voltage is below 6.90 volts, and will continue at the higher rate of charge until either the battery voltage reaches 7.35 volts or the instrument is switched from Standby to ON. Once the battery voltage reaches 7.35 volts, the battery is trickle charged at a 10 mA rate.

8-254. If the battery has not been charged to near 100% capacity by the charger, the 10 mA current is not sufficient to keep the battery above 6.90 volts. The high current charge rate will again be activated until the battery voltage reaches 7.35 volts. The charger will continue to cycle from low to high charge rates as the battery voltage varies between 6.90 and 7.35 volts. The difference between the two voltages is a hysteresis band of .45 volts.

8-255. Potentiometer R26 on the A3 battery charger board is used for setting the upper hysteresis point to 7.35 volts. The lower hysteresis point automatically tracks .45 volts below the upper setting. The upper hysteresis level is set to 7.35 volts at 25°C. Temperature compensation is provided by CR7. At some point near full charge, the 10 mA current will prevent the battery voltage from dropping below 6.9 volts, and the battery is then trickle charged.

8-256. When the battery voltage drops to 5.95 volts, comparator U2 causes Q1A to saturate. The active low output of Q1A causes a LO BATT indicator to appear on the front panel display. The counter will continue to operate for approximately 20 minutes longer.

8-257. When the battery voltage drops to 5.35 volts, the counter may not operate reliably, so the counter

power supply will be automatically turned off. Battery voltage of 5.35 volts causes comparator U2D to saturate Q1C. The output of Q1C is sourced to pin 9 of U9 in the DC to DC converter power supply on the A1 motherboard. The RC network R7 and C2 create a time constant that delays the reference voltage from pin 2 of U1 long enough to prevent power supply shutdown on initial power up of the counter. Diode CR2 and capacitor C5 integrate the dc input which holds the dc input voltage on U2D long enough to prevent the power supply ripple caused by the dc-to-dc converter from causing premature shutdown. R16 provides hysteresis for the shutdown detection circuitry so the instrument will not cycle on and off.

8-258. TROUBLESHOOTING

8-259. Introduction

8-260. The HP 5384A/HP 5385A is a microcomputer based system. Part of the instrument circuitry consists of digital logic controlled by the microcomputer. Troubleshooting is accomplished by using built-in diagnostics and manual tests.

8-261. The troubleshooting philosophy for the counter is to divide the counter into five main blocks so the problem can be more easily isolated. Once the faulty block has been isolated, refer to the appropriate schematic diagram. If the repaired circuit requires adjustment after being repaired, refer to Section V and perform the adjustments as described.

CAUTION

Proper static handling techniques must be employed when servicing semiconductor products. The voltage susceptibility of all IC and transistor families are well below levels commonly found in service environments. Exercise care and observe standard static precautions.

8-262. Listed below are some special considerations and helpful hints to keep in mind when troubleshooting the 5384A/5385A. They will help avoid potential problems when troubleshooting.

a. When making measurements at IC sockets (with the IC removed), avoid inserting the probe tip into the sockets. This may cause contact problems when the IC is re-inserted. Attach a piece of 26-gauge wire to the probe and insert the wire into the socket.

b. When an LSI IC is removed, it should be placed in conductive foam to avoid static damage. If conductive foam is not available, handle the IC by the ends of the package.

8-263. Built-in diagnostics

8-264. The HP 5384A/HP 5385A provides six built-in diagnostic routines, including the Power-Up Self Check that occurs automatically when power is applied to the counter. If your instrument has an optional interface installed, the interface is also automatically tested during Power-Up. The built-in diagnostics may be accessed from the front panel or through the interface (if installed). The diagnostics are:

Power-Up Self-Check	Occurs automatically when power is applied.
CPU	Checks the ROM and RAM of the microcomputer memory.
I/O Address	Checks the interface option, bus lines and the ports on the microcomputer.
Interpolator Short Cal	Checks the circuitry that produces a short calibration pulse used in the calculation of the two least significant digits of the display.
Interpolator Long Cal	Checks the circuitry that produces a long calibration pulse used in the calculation of the two least significant digits of the display.
Microprocessor Port Test	Checks all 32 microprocessor port lines. Some manual probing required.

8-265. Accessing The Built-In Diagnostics

8-266. The front panel CHECK key is used for manual access to the diagnostic routines. Command codes provide access to the diagnostics from a controller. The following paragraphs describe the key press sequences and the command codes required to execute the various diagnostics.

8-267. After power-up occurs, the diagnostic mode is entered by pressing the CHECK key twice. If the CHECK key is pressed only once, the 10 MHz internal

oscillator frequency is displayed. If no other key is pressed, and the CHECK key is pressed a second time, the first diagnostic mode, CPU, is selected automatically. Once a diagnostic routine is selected, the routine will run continuously until another routine is selected or the routine is aborted by pressing the RESET key.

8-268. If the CHECK key is pressed once and any other front panel key is pressed, the counter goes into the Power-Up Initialize State.

8-269. Power-Up Self-Check

8-270. When power is applied to the counter, a "star-burst" pattern is sent to the display, turning on all of the LCD segments. In this manner the display driver circuits and the LCD segments on the A2 are tested. The routine is not accessible through the optional interface.

8-271. While the "star-burst" is displayed, the microcomputer also performs the CPU check. The CPU diagnostic checks the ROM and RAM of the microcomputer A1U1.

8-272. CPU Check

8-273. The 64-byte scratch-pad RAM of the A1U1 microcomputer is checked for read/write errors. The routine also performs a check-sum operation that tests the ROM of the microcomputer for bit errors. All 4032 bytes of ROM are scanned and their hexadecimal values are accumulated and compared with a predetermined check-sum value.

8-274. To access the CPU Check from the front panel, press the CHECK key twice. To access the CPU Check from a controller, use the command code FN11.

Example: wrt703, "FN11"
(703 is an arbitrary HP-IB address selected
for the purpose of illustration)

8-275. I/O Address

8-276. In the I/O Address diagnostic, the HP-IB or HP-IL bus address setting of the interface will be displayed continuously. A typical display would be "ADDRESS 03". If no interface were installed, the display would appear, "ADDRESS --". If the address switches are changed while the I/O Address diagnostic is running, the new setting will be automatically displayed.

8-277. To access the I/O Address Check from the front panel, press the CHECK key twice and the PER (period) key once. To access the I/O Address Check from a controller, use the command code FN12.

Example: wrt703, "FN12"

8-278. Interpolator, Long and Short Calibration

8-279. The interpolator circuitry, which provides the two least significant digits of resolution, is tested by either the long or the short calibration routine. Both routines are identical except for the absolute value of the numbers displayed and the access code/key press sequence. In both routines, the "start" and "stop" calibration numbers are displayed simultaneously. The calibration numbers are each three digits long. They can range from 000 to 255 with four spaces separating the two numbers. The value of the numbers is not critical as long as they are neither 000 nor 255 and the values do not vary more than three counts. If the calibration values are 000, or 255, or vary more than three counts, the interpolator (consisting of A1U11 and A1U12) is faulty.

8-280. The calibration numbers can be read out over either interface option. The numbers are combined into a single 12-digit string which may be read continuously.

8-281. To access the Short Interpolator Calibration check from the front panel, press the CHECK key twice and the FREQ (B) key once. To access the Long Interpolator Calibration check, press the CHECK key twice and the 0.1S (GATE) key once.

8-282. To access the Short Interpolator Calibration check from a controller use the command code FN13 (FN14 for long calibration).

Example (access): wrt703, "FN14"
(read): red703, Y\$

NOTE

Y\$, if displayed as a string variable without some formatting would not be as convenient to interpret as it would if one of the following controller programming examples were used.

```
HP 85
ENTER 703; Y$
A=100*VAL (Y${3,6})
B=VAL (Y${12,14}); B
DISP A,B
```

```
HP 9825A
red 703,Y$
100val (Y${3,6})→A
val (Y${12,14})→B
dsp A,B
```

8-283. Microprocessor Port Check

8-284. The Microprocessor Port Check diagnostic sends a shifting pattern of ones and zeroes to all 32 lines of the microprocessor ports. The same pattern appears on all ports. One pin on each of the four ports will be low at any given time; the rest will be high. The low will be shifted from the port least significant digit (LSD) to the most significant digit (MSD) and then back to the LSB in a continuous sequence. The resulting port activity may then be checked with a logic probe, oscilloscope, or voltmeter. The test is useful in searching for a stuck, shorted or open portline.

8-285. Access the Microprocessor Port Check by shorting Test Point 1 and Test Point 2 together on the A1 Motherboard then power-up the instrument. The diagnostic routine is automatically entered and will continue until the short between test points 1 and 2 is removed and a power-up reset is initiated by recycling the power switch from STBY to ON. The Microprocessor Port Check is not accessible by any other method than described above.

8-286. MANUAL TROUBLESHOOTING

8-287. For troubleshooting purposes the counter can be divided into the following five blocks. The blocks are listed in the sequence you should use when first troubleshooting the counter. Refer to *Figure 8-49, Troubleshooting Flowchart*, to aid in troubleshooting. (As you gain experience with the counter, you may recognize fault symptoms that will lead you directly to the problem.)

- a. Power Supplies
 1. +5 Volt Supply
 2. +3 Volt Supply
 3. A3 Battery Pack Assembly Option 005
- b. Time Base
 1. Standard Oscillator
 2. TCXO Option 001
 3. Oven Oscillator Option 004
- c. Main Counter and Display
 1. A1U1, A1U2, Interpolators, and Frequency Dividers
 2. A2 LCD Assembly
- d. Channel A and B Input Amplifiers
- e. Remote Control
 1. A4 HP-IL Interface Assembly
 2. A5 HP-IB Interface Assembly

8-288. Power Supply Troubleshooting

a. Check rear panel fuse F2. If the fuse is blown, check the +5 volt line for short circuits. Typical resistance: +5 volts to ground test point, 45 ohms.

b. Check fuse F1 on the A1 motherboard. If the fuse is blown, check T1 and CR8.

c. Check the 3 volt line for short circuits. Typical resistance: +3 volts to Ground Test Point, 90 ohms.

d. A short on the +3 volt supply will cause A1U10 to become very warm.

If a short is found on one of the supply lines, refer to *Table 8-7* for information on which circuit is powered by each power supply.

Table 8-7. Power Supplies and Associated Assemblies

+5 Volts	All Assemblies
+3 Volts	A1U1, A1 Buffer, A1 Level Translators

e. Measure the main power supplies. Both supplies should be within the values specified below. If the +3 volt supply is out of tolerance, adjust it to the voltage indicated below.

+5 volts	±10 mV	no adjustment
+3 volts	±10 mV	adjust A1R77

f. If both power supplies are found to be low, verify that +5 volts is present at A1U7(3). If +5 volts is present, check A1U8(2) for +2.5 volts. If +2.5 volts is present, check for 0.6 to 0.7 volt pulses at the base of Q12. If pulses are not present here, check U9, then Q11, then Q12.

8-289. OSCILLATOR TROUBLESHOOTING

8-290. Standard Oscillator (HP 5384A only). To verify proper operation of the oscillator, check for a 10 MHz sine wave at the emitter of Q13 (see *Figure 8-43*). If the signal is not present then check Q13, Q14, and Y1C respectively. *Figure 8-43* shows the output waveform of the standard oscillator.

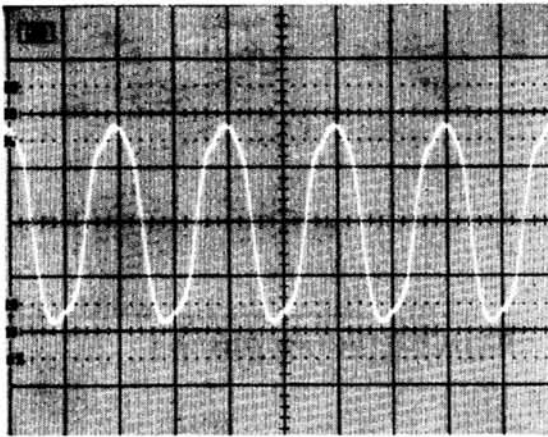

Oscillator signal at emitter Q13
0.5V/div.
50 ns/div.
ac coupled

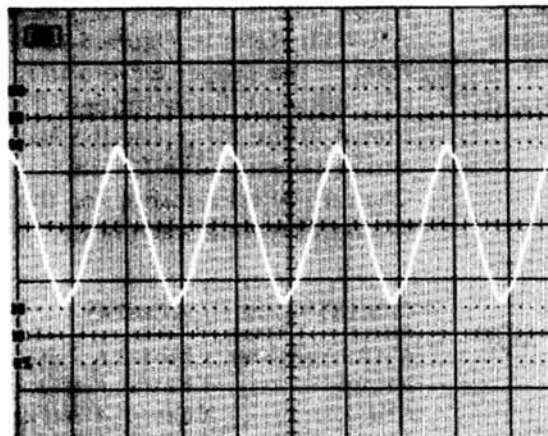

Reference Oscillator Output
signal at rear panel.
1V/div.
50 ns/div.
ac coupled

Figure 8-43. Standard Oscillator Waveform

8-291. **OPTION 001 (TCXO).** If the HP 5384A/HP 5385A has Option 001 and the oscillator has no output or a low output, verify that +5 volts is present at C67. If +5 volts is present at C67, the oscillator module is

defective and must be replaced; it is not repairable. The correct waveform for Option 001 (TCXO) is shown in *Figure 8-44*.

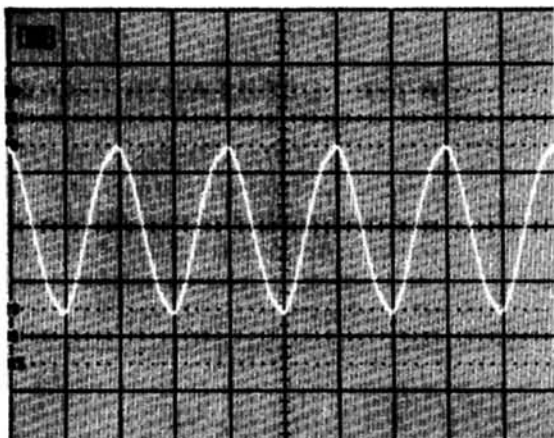

TCXO Signal at Emitter Q13
0.5V/div.
50 ns/div.
ac coupled

Figure 8-44. Option 001 (TCXO) Oscillator Waveform

8-292. **OPTION 004 OVEN OSCILLATOR.** If the HP 5384A/HP 5385A has Option 004 and the oscillator has no output or low output, verify that +5 volts is present at L5 (probe the lead closest to the rear panel). If +5 volts is present, the oscillator module is defective and must be replaced; it is not repairable.

8-293. Input Amplifier Troubleshooting

8-294. To prepare the HP 5384A/HP 5385A Channel A input amplifier for troubleshooting:

- Apply a 10 MHz signal at 25 mV rms (70 mV p-p) to Input A.
- Select **FREQ A** or **PER A** on the counter.
- Use an oscilloscope (and probe) suitable to display a 10 MHz waveform.

8-295. Referring to the A1 schematic diagram in *Figure 8-50* or *Figure 8-51*, check for a waveform at A1U1(30). Refer to *Figure 8-45* for the proper waveform. If the proper waveform is not present, probe the following list of nodes. (Follow the sequence shown in the list or use the half-splitting technique and begin with node A1U3B(5).) Refer to *Figure 8-45*, Channel A Waveforms, for the proper signal you should observe at each node.

CIRCUIT NODE CIRCUITRY

A1CR3 (cathode)	Channel A signal conditioning output
A1U3A(10)	Channel A 1st gain stage input
A1U3B(5)	Channel A 2nd gain stage input
A1U3B(2)	Channel A Schmitt trigger input
A1U6B(14)	Channel A Level Translator input
A1U1(30)	Channel A signal line to MRC

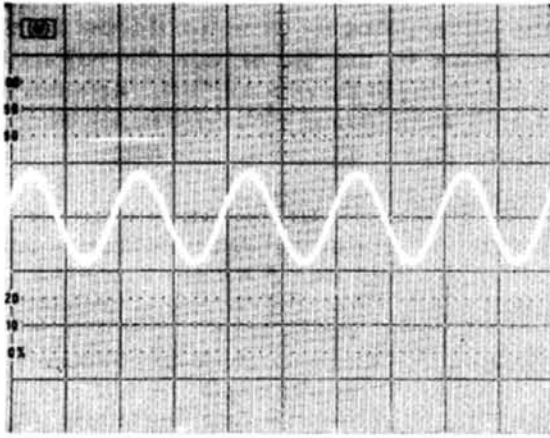

A1CR3(cathode) dc coupled
0.05V/div .05 μ s/div.

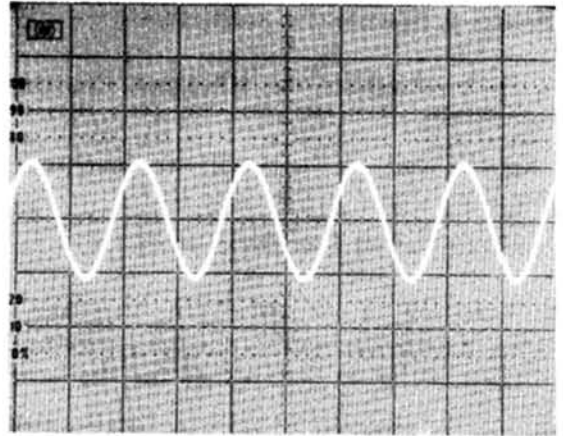

A1U3A(10) .05 μ s/div.
0.05V/div ac coupled
dc level is approximately 3.4V

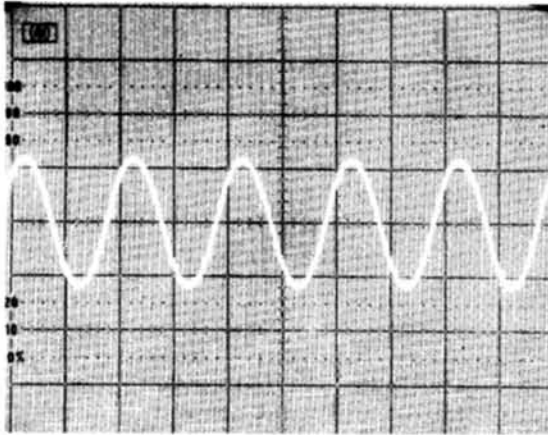

A1U3B(5) 0.05 μ s/div.
0.2V/div ac coupled
dc level is approximately 3.6V

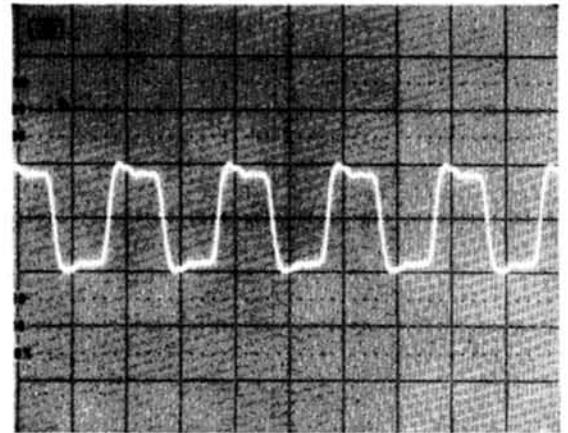

A1U3B(2) 0.05 μ s/div.
0.5V/div ac coupled
dc level is approximately 3.6V

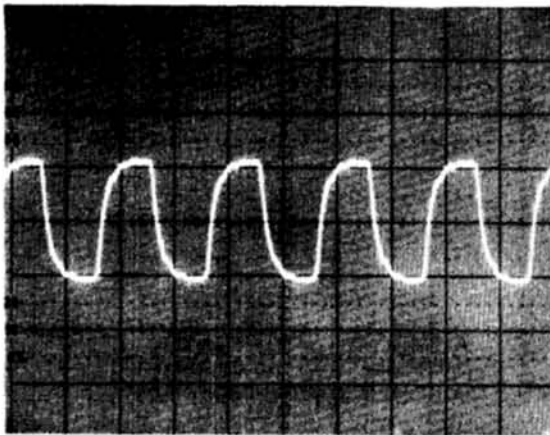

A1U6B(14) 0.05V/div.
0.2V/div ac coupled
dc level is approximately 2.8V

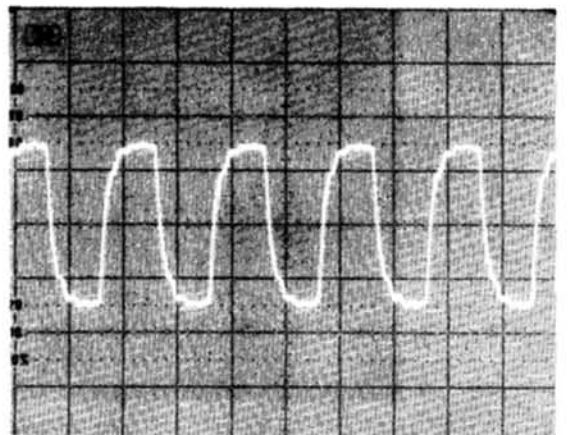

A1U6B(12) 0.05 μ s/div.
0.2V/div ac coupled
dc level is approximately 2.8V

Figure 8-45. HP 5384A/HP 5385A Channel A Waveforms

8-296. After repairs are made, perform the required adjustments as described in Section V.

8-297. To troubleshoot the HP 5384A Channel B input amplifier:

- a. Apply a 100 MHz signal at 25 mV rms (70 mV p-p) to input B.
- b. Select Channel B on the counter.

8-298. Referring to the HP 5384A A1 Schematic Diagram, *Figure 8-50*, check for the proper waveform at A1U6(11). Refer to *Figure 8-46* for the proper waveform.

8-299. If the proper waveform is not at A1U6(11), probe the following list of nodes. (Follow the sequence shown in the list or use the half-splitting technique and begin with A1U5(11).) Refer to *Figure 8-46*, HP 5384A Channel B Waveforms, for the proper signal you should observe at each node.

CIRCUIT NODE	CIRCUITRY
A1U4B(13)	Channel B signal conditioning output
A1U4B(14)	Channel B 2nd gain stage input
A1U4A(3)	Channel B divide-by-4 frequency divider input
A1U5A(2)	Channel B divide-by-4 frequency divider output
A1U6A(11)	Channel B signal line to MRC

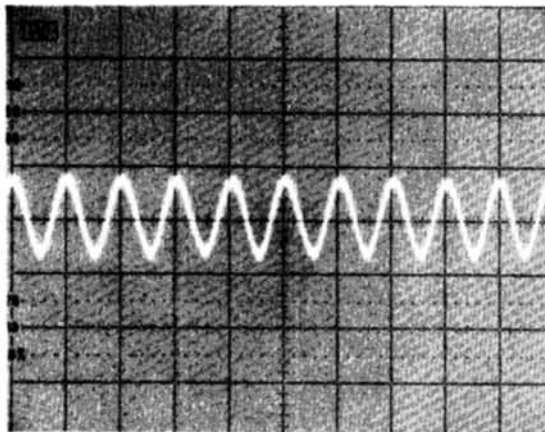

A1U4B(13) 0.01 μ s/div.
0.01V/div. ac coupled
dc level is approximately 3.6V

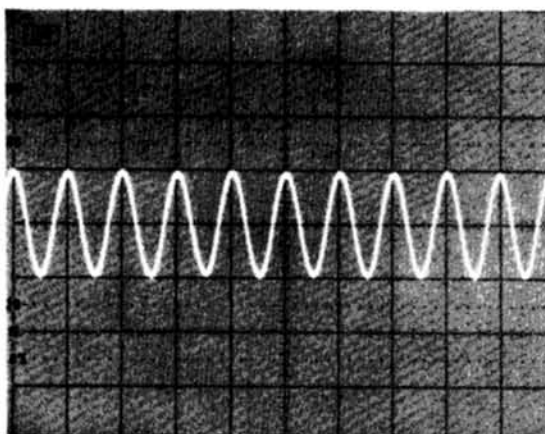

A1U4B(14) 0.01 μ s/div.
0.05V/div. ac coupled
dc level is approximately 3.6V

Figure 8-46. HP 5384A Channel B Waveforms

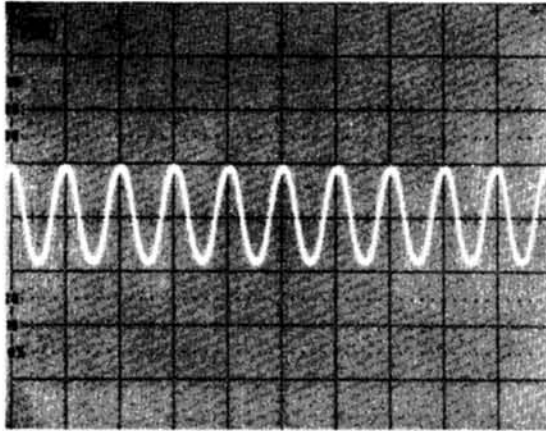

A1U4(3) 0.01 μ s/div.
0.1V/div. ac coupled
dc level is approximately 3.6V

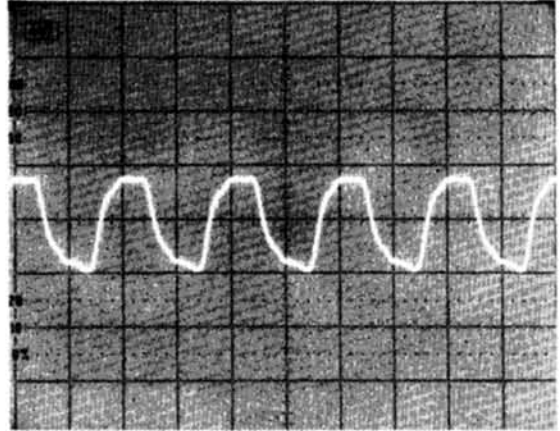

A1U5A(2) 0.02 μ s/div.
0.5V/div. ac coupled
dc level is approximately 3.8V

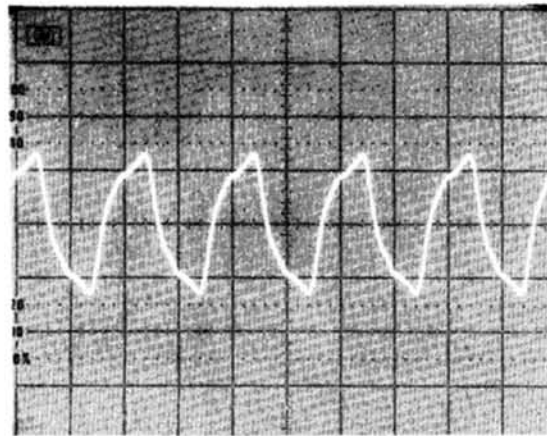

A1U6(11) 0.02 μ s/div.
0.2V/div. ac coupled
dc level is approximately 2.8V

Figure 8-46. HP 5384A Channel B Waveforms (Continued)

8-300. To troubleshoot the HP 5385A Channel B input amplifier, first check for a blown INPUT fuse. Refer to Figure 2-5. If the fuse is blown, replace it and apply a 100 MHz signal at 25 mV rms (70 mV p-to-p) to the Channel B input BNC. Press the **FREQ B** key. Referring to Figure 5-3, check that the proper waveform exists at A1U6A(11). If the proper signal is not present, probe the following list of nodes. (Follow the sequence shown in the list or use the half-splitting technique and begin with A1U19(10).) Refer to Figure 8-47, HP 5385A Channel B Waveforms, for the proper signal you should observe at each node.

CIRCUIT NODE

A1CR25 (cathode)
A1L10 (lead nearest front panel)
A1L12 (lead nearest front panel)
A1U19(10)
A1U19(4)
A1U6A(11)

CIRCUITRY

Channel B limiter output
Channel B 1st gain stage output
Channel B 2nd gain stage output
Channel B divide-by-256 frequency divider input
Channel B divide-by-256 frequency divider output
Channel B to MRC output

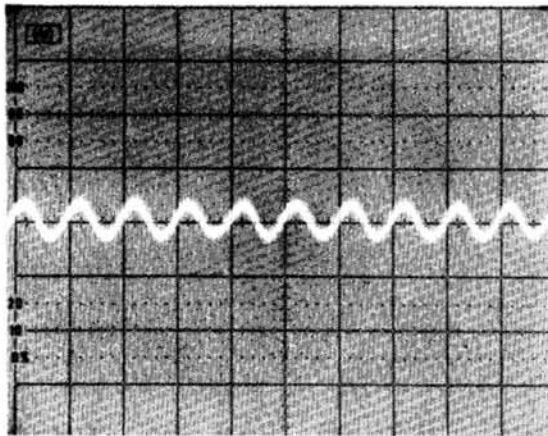

A1CR25 0.01 μ s/div.
0.01V/div. dc coupled

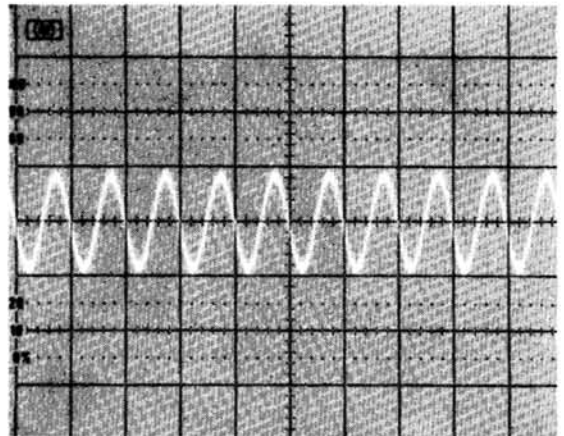

A1L10 (lead nearest front panel)
0.01V/div. ac coupled
0.01 μ s/div.
dc level is approximately 2.0V

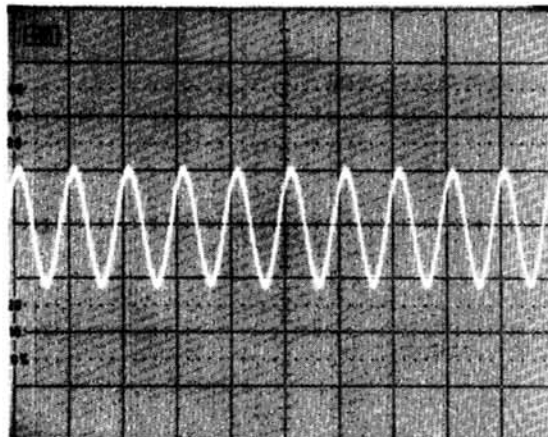

A1L12 (lead nearest front panel)
0.02V/div. ac coupled
dc level is approximately 2.0V

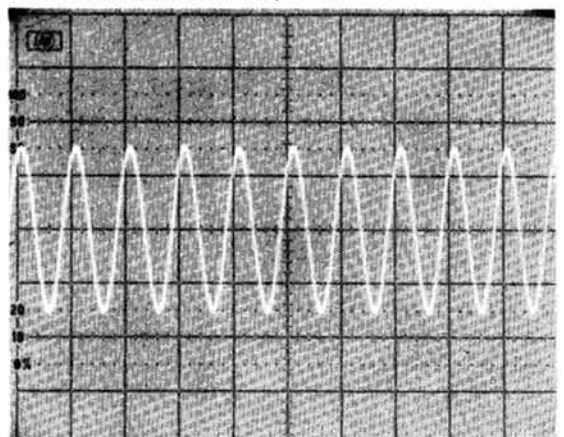

A1U19(10) 0.01 μ s/div.
0.1V/div. ac coupled
dc level is approximately 2.4V

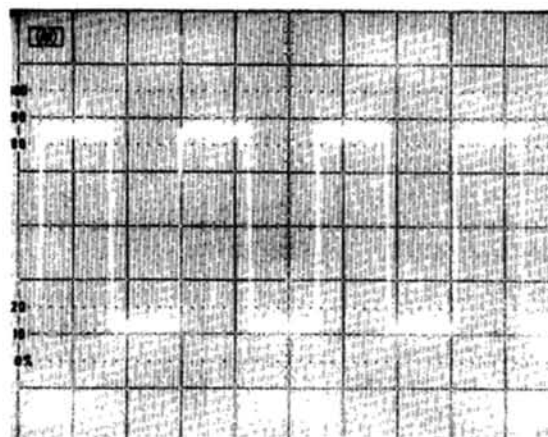

A1U19(4) 1 μ s/div.
0.2V/div. ac coupled
dc level is approximately 3.4V

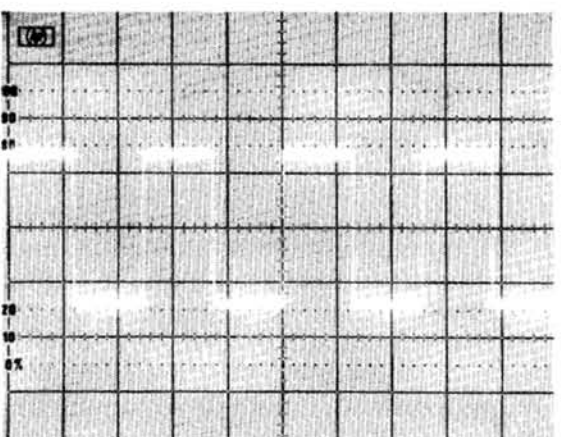

A1U6A(11) 1 μ s/div.
0.2V/div. ac coupled
dc level is approximately 2.8V

Figure 8-47. HP 5384A Channel B Waveforms

8-301. Battery Pack Troubleshooting

8-302. Troubleshooting the battery pack is accomplished by performing various tests and by using *Table 8-8, Battery Pack Troubleshooting*.

8-303. Battery Charger Board Troubleshooting

8-304. Problems on the Battery Charger Board can be isolated to either the charging or discharging portion. A fault in the charging circuits will affect the battery charge capability. A fault in discharge circuitry will affect proper instrument operation in the battery mode.

8-305. The charging portion of the Battery Charger Board consists of:

- a. 10 mA constant current source.
- b. 500 mA constant current charger.
- c. Charge control circuit.

8-306. The discharging portion of the Battery Charger Board consists of:

- a. Power-up delay circuit (A3CR2 and A3C5)
- b. Disabling comparator circuit (U2D and associated components)

8-307. Charging Circuit Troubleshooting Test

a. Attach the line cord and set the counter power switch to STBY.

b. Place the battery charger in the fast charge mode by shorting A1U2(12) to ground. Do this by placing a short across A3R20.

8-308. The voltage across A3R1 should measure approximately 0.025 volts (actual voltage is determined by the setting of A3R25).

8-309. Battery Load Current Test

8-310. The Battery Load Current Test consists of measuring the battery discharge current during counter operation to detect an abnormal condition. Typically, the battery load current will be approximately 900 mA. If the Option 004 Oven Oscillator is installed, the load current will increase. The load current will increase by approximately 300 mA if the oscillator is cold and maximum heating current is being drawn. The load current will increase by 150 mA when the oven is warm and the temperature has stabilized. Measuring the load current may be accomplished by any one of the three following methods.

- a. Couple a dc current probe to either battery lead.
- b. Substitute a dc power supply in place of the battery. The power supply must have floating (ungrounded) outputs, provide an output current indication, and be capable of delivering 1-2 amps. Set the dc voltage to approximately 6.3 volts.
- c. Measure the voltage drop across A3R1 and calculate current flow through the resistor.

Table 8-8. Battery Pack Troubleshooting

Counter will not operate in battery mode.	Defective battery Open fuse Discharged battery Auto shut-down occurs at Turn-On	Dead cell, will not hold charge. Perform Battery Charge State test. Possible short. Fault in charger circuit. Perform the Charger Circuit Troubleshooting Test. Fault in disabling circuitry on the Power-Up delay circuitry. Check these circuits.
Counter operates normally, however, shut-down occurs too early.	Defective battery Counter operating current too high. Battery charge low Incorrect low battery level detection	Battery has low capacity or weak cell. Perform Battery Capacity test. Instrument fault causes high operating current. Measure battery current. Charge comparator trip point incorrect. Charge circuit defective. Perform the Charging Circuit Troubleshooting test. Fault in disabling comparator circuit. Perform Shut-down Voltage test.

8-311. Shut-Down Voltage Test

8-312. The Shut-down Voltage Test verifies that the sensing network of the disabling Comparator circuitry is operating within the design range.

- a. Remove the line cord from the counter and set the power switch to STBY.
- b. Disconnect the battery from the charger board.
- c. Set a dc power supply to approximately 6.3 volts with current limiting set for greater than 1 amp.
- d. Substitute the power supply in place of the battery. The power supply must have floating (ungrounded) outputs.
- e. Power up the counter.
- f. While monitoring the dc power supply voltage with a DVM, slowly decrease the voltage until the counter turns off. The counter should turn off at approximately 5.95 volts.

8-313. Battery Tests

8-314. A defective battery may cause symptoms that erroneously indicate a fault in the battery charger circuit. If the battery is suspected of being faulty, the following two tests can be conducted to determine battery condition.

- a. Charge State Test
- b. Capacity Test

8-315. Charge State

8-316. The state of charge of the battery can be determined by performing an open circuit voltage measurement and comparing the reading with *Table 8-9, Battery State-of-Charge*. The table is accurate to $\pm 20\%$ of rated capacity if the battery has not been charged or discharged within the past 24 hours. This tolerance narrows to $\pm 5\%$ if the battery has been idle for 5 days or longer.

Table 8-9. Battery State-of-Charge

Terminal Voltage	Percent of Rated Capacity
6.53V	100%
6.42V	80%
6.25V	50%
6.12V	30%
6.00V	10%

8-317. Should the open circuit voltage measure below 4.5 volts at any time, a dead cell may be

indicated. The battery must be replaced. Alternately, a deeply discharged battery condition may exist which will present difficulties (poor charge acceptance) if attempting to recharge with the Battery Pack Charger.

8-318. Capacity Test

8-319. Performing the capacity test will determine if the battery has adequate capacity to operate the counter for 4 hours. To perform the test, a dc power supply and a resistive load are required. The dc power supply must be settable to 7.2 volts and capable of delivering at least 1 amp of current. Use a resistive load of 6 ohms and capable of dissipating 20 watts.

a. The battery must be brought up to full charge prior to testing. Turn on and set the power supply to 7.2 volts dc with current limiting set to 1 amp or greater. Connect the power supply to the battery, observing correct polarity. Depending on the state of battery charge, the battery will accept maximum current when first connected then taper off as the charge level increases. Or, if the battery has been deeply discharged, its initial charge acceptance will be low. This condition should correct itself during the first few hours of charging. The charge mode should be terminated when the charging current diminishes to approximately 10 mA.

NOTE

The battery can be left in the trickle-charge mode (as above) for an indefinite period without damage to the battery. The power supply voltage, however, must not exceed 7.2 volts.

b. Capacity testing is performed by discharging the battery at a specified rate and noting the elapsed discharge time required for the terminal voltage to drop to 5.4 volts.

WARNING

DO NOT TOUCH THE LOAD RESISTOR DURING THE TEST. THE RESISTOR WILL BECOME VERY HOT.

c. Connect the battery to the 6 ohm load resistor. Monitor the Battery Terminal Voltage with a DVM and note the amount of time it takes for the terminal voltage to drop to 5.4 volts. The battery has acceptable capacity if it requires four or more hours to discharge to the 5.4 volt level. Recharge the battery as soon as possible if it is to be returned to service.

8-320. HP-IB Interface Assembly (A5 Board) Troubleshooting

8-321. At Power-Up, the HP-IB interface is tested. An ERROR:I/O message will appear on the display if the test did not pass. If the test passes, the address of the interface will appear on the display.

NOTE

If all the switches on the DIP switch, A5S1, are set to 1 (open or upward) the error message will appear on the display.

8-322. If the I/O address diagnostic fails and the counter passes all other diagnostics, verify that the ribbon cable A5W1 is properly seated in its motherboard connector A1J8.

8-323. Verify the following voltages on the A5 board assembly:

SIGNAL NAME	TEST POINT	RANGE
+5 volts	+5 (TP1)	±0.2 volts
+5 volts cmc	U2, pin 24	±0.2 volts

8-324. Verify that a 3.5 MHz (nominal) clock signal is present at U5 pin 2.

8-325. A signature analysis mode is available for the A5 board assembly. This technique is helpful to determine failed components on the A5 assembly. For problems involving a particular controller, it is recommended that an HP 59401A Bus Analyzer and logic analyzer be used to determine the cause of the problem. As an initial test, verify that the interface responds properly to the HP-IB test program found in Section IV. Also verify that the controller interface is functioning properly. An HP-IB test tape (HP part Number 59300-10002, Revision G) is available for use with the HP85 desk top controller.

8-326. To perform signature analysis for the A5 assembly, proceed as follows:

- Remove the ac power cord from the rear panel of the counter.
- Remove the HP-IB assembly from the counter.
- Set all of the switches on the DIP switch, A5S1, to 1 (open or upward).
- Connect +5 volts and ground to the A5 assembly. The +5 volts source can be either the +5 volt supply in the counter or a separate +5 volt supply that has as good or better regulation than that of the counter's power supply. If the counter is used as the +5 volt source, it is convenient to clip on to TP2 on the motherboard for the +5 volts and TP10 for the ground. On the A5 board, +5 volts may be connected to the lead nearest W1. Ground may be connected to

the lead of C4 nearest to W1. (Do not use J3 pin 8 for a power supply connection.)

- Connect a signature analyzer such as the HP 5005B to the A5 assembly as follows:

TIMING POD	TEST POINT
START/ST/SP (green lead)	ST (TP2)
STOP/QUAL (red lead)	SP (TP3)
CLOCK (yellow lead) (black lead)	CK (TP4) (TP5)

- Make the following settings to the HP 5005B:

CLOCK	negative slope
START	negative slope
STOP	negative slope

- Connect a test lead between PAT (TP1) of the A5 assembly and ground. If the counter is used as a +5 volt supply for the A5 assembly, reconnect the line cord to the rear panel and switch the counter on.

h. Remove the test lead from the PAT test point. The microprocessor checks this line at Power-Up and then goes into the signature analysis mode. The PAT point must be grounded on Power-Up to generate START and STOP signals, however, a valid signature can only be taken at this point with the grounding clip removed. All other signatures on the A5 board should remain identical regardless of the status of PAT (TP1).

- After verifying the characteristic signatures, V_{cc} and ground, verify the signatures shown in Figure 8-50. It is recommended that signatures on the HP-IB microprocessor, U5 be checked first as this is where the signal activity is generated.

8-327. The signature analysis routine does not verify the \overline{REN} line and the I/O lines between the A5 microprocessor and the main microprocessor on the motherboard. Install the A5 assembly into the instrument and reset the A5S1 DIP switch to its original setting. Enter the following program into an HP85 and connect the HP-IB interface to the counter. Note that for line 10 in the program, the appropriate address for the counter should be entered (714 is used for example only).

```

10 Remote 714
20 Local 7
30 Go to 10
40 End

```

8-328. Run this program and verify activity at A5U5(27). If there is no activity at this point, trace back through U4D, U4A, and U2 to locate the fault. Also, verify activity on U5, pins 3, 4, 5, 6, 16, 17, and 18. If there is no activity on these lines, a problem may exist in the interface between the A1 Microprocessor assembly and the A5 HP-IB Interface Assembly.

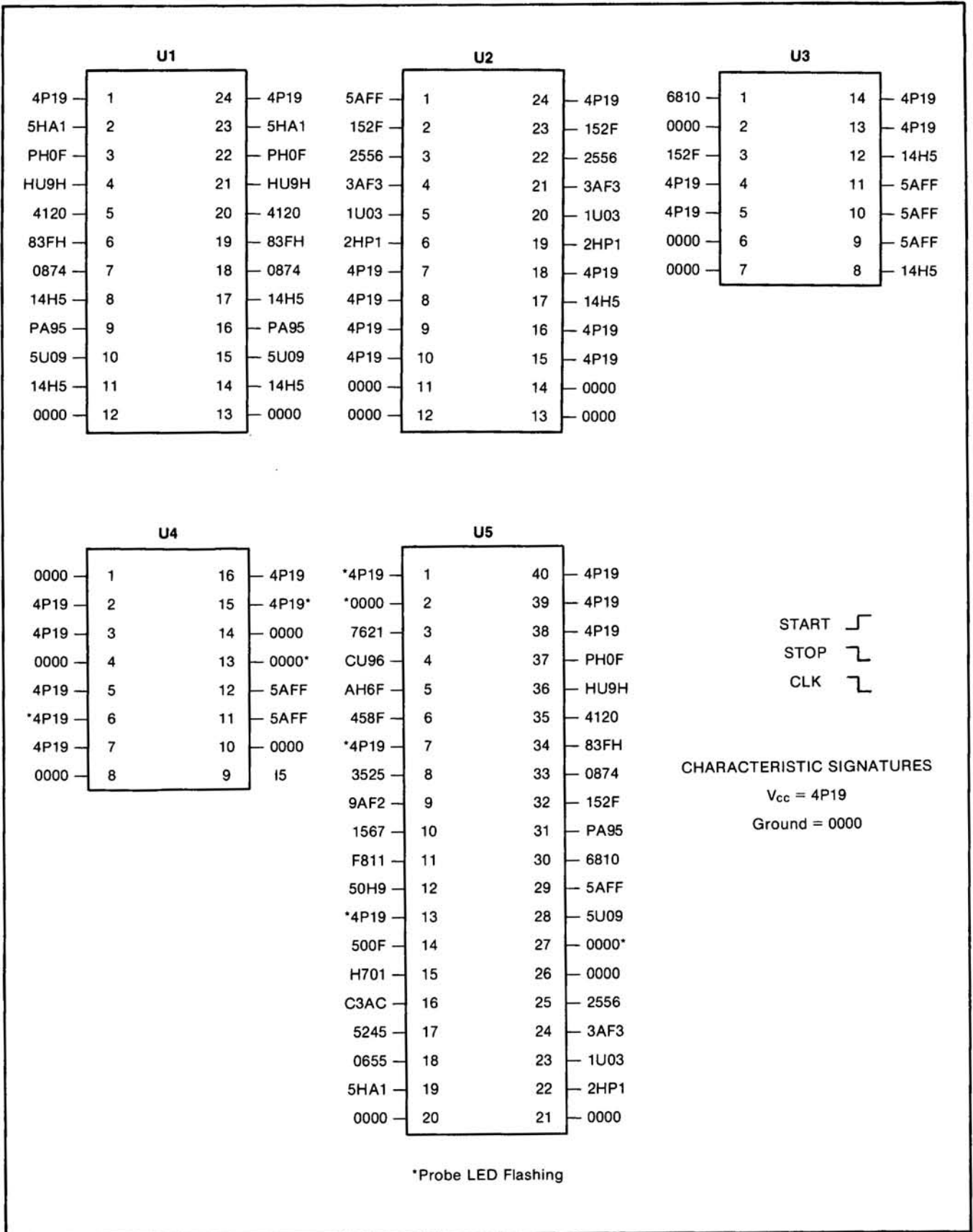

Figure 8-48. All Signatures for the HP 5384A and HP 5385A Motherboard

Figure 8-49

TROUBLESHOOTING FLOWCHART

(See Page 8-45)

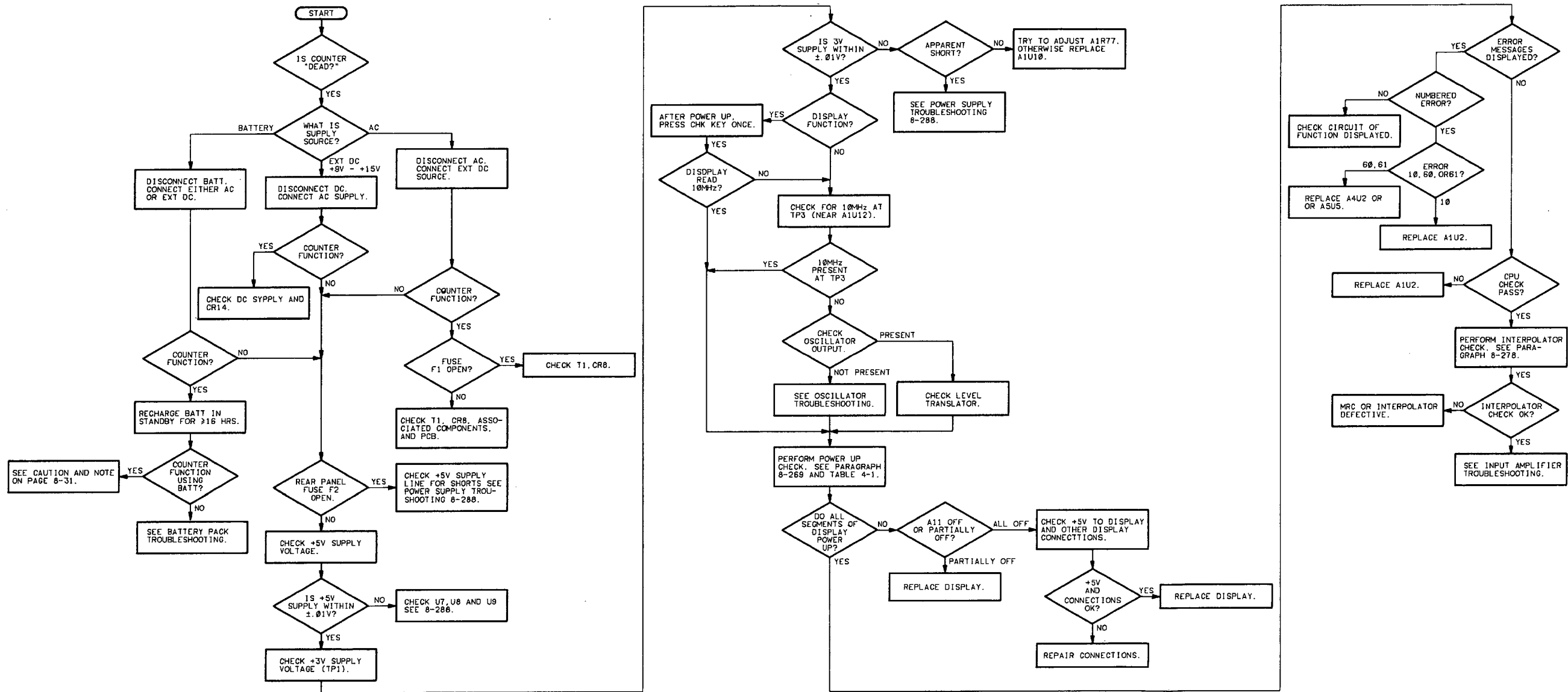

Figure 8-49. Troubleshooting Flowchart

Figure 8-50

HP 5384A A1 MOTHERBOARD ASSEMBLY

(Sheet 1 of 2)

(See Page 8-47)

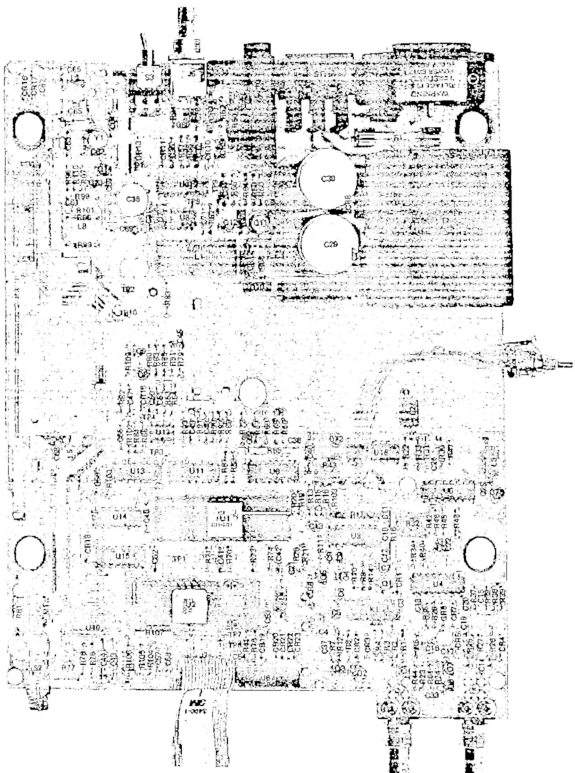

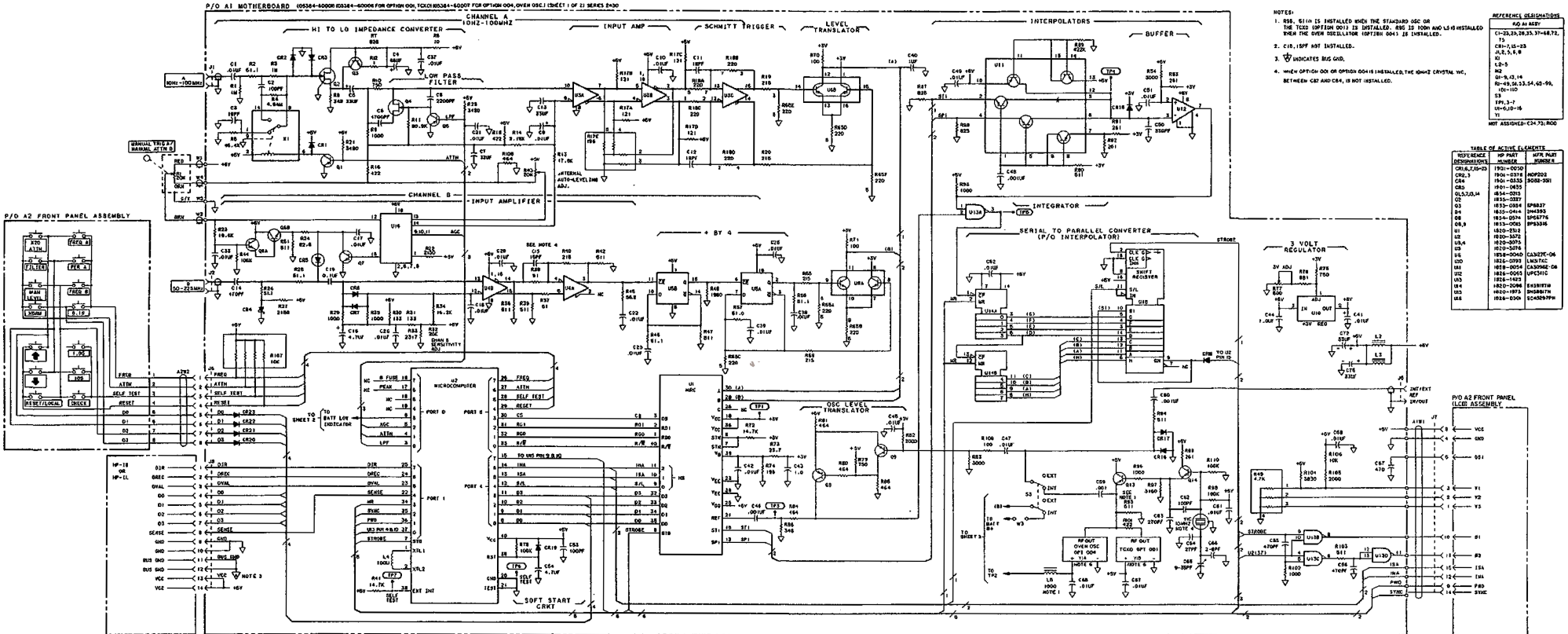

Figure 8-50

HP 5384A A1 MOTHERBOARD ASSEMBLY

(Sheet 2 of 2)

(See Page 8-49)

P/O A1 MOTHERBOARD (POWER SUPPLY) (05384-60001) (05384-60006 FOR OPTION 001, TCXO) (05384-60007 FOR OPTION 004, OVEN OSC) (SHEET 2 OF 2)

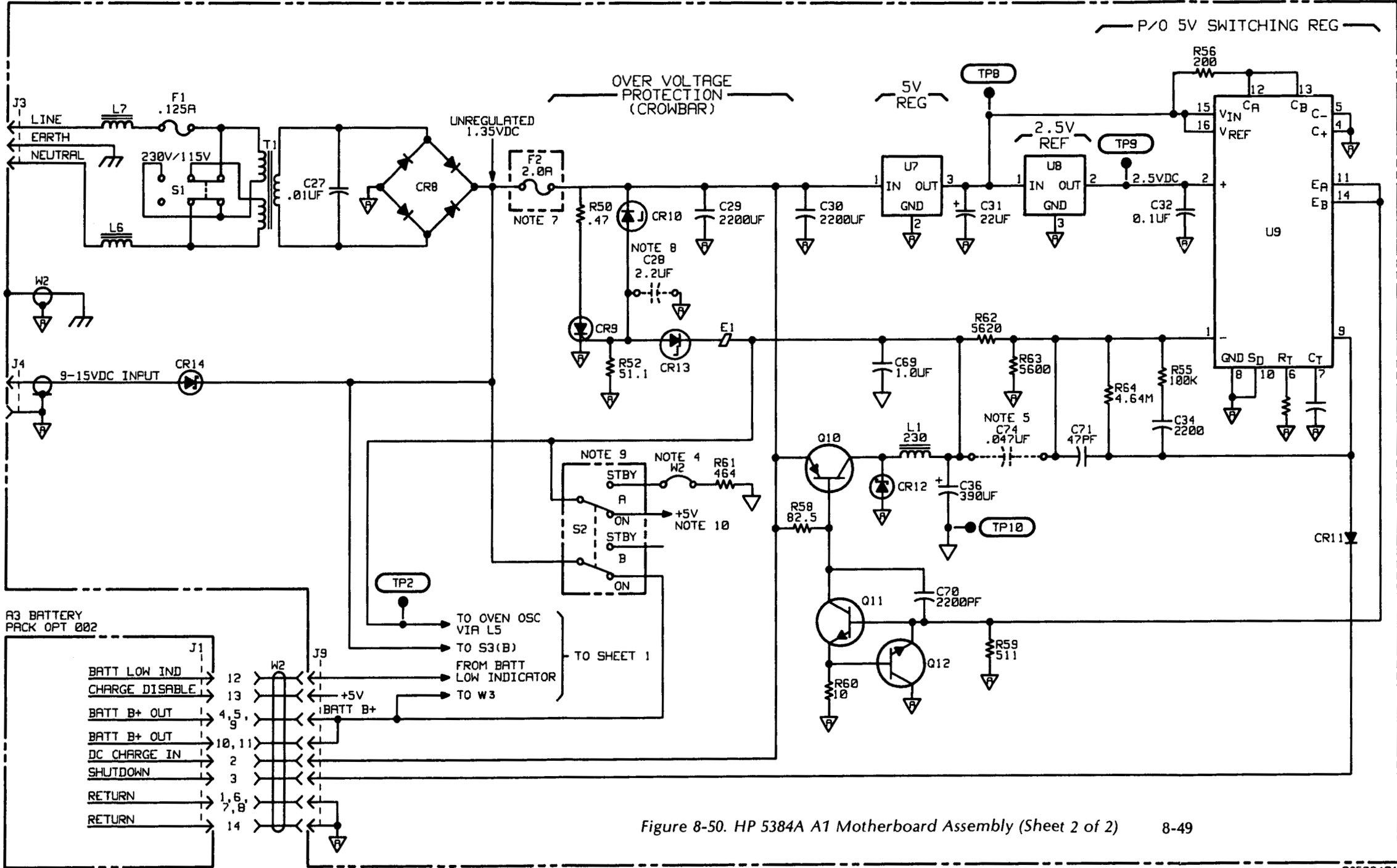

- NOTES
1. REFERENCE DESIGNATIONS WITHIN THIS ASSEMBLY ARE ABBREVIATED. ADD ASSEMBLY NUMBER TO ABBREVIATION FOR COMPLETE DESCRIPTION.
 2. UNLESS OTHERWISE INDICATED:
RESISTANCE IN OHMS;
CAPACITANCE IN MICROFARADS;
INDUCTANCE IN MICROHENRIES.
 3. ASTERISK (*) INDICATES SELECTED COMPONENT, AVERAGE VALUES SHOWN.
 4. JUMPER W2 IS REMOVED WHEN OPTION 004 IS INSTALLED.
 5. C74, .047UF IS NOT INSTALLED.
 6. ▽ INDICATES A COMMON CONNECTION.
 7. F2 IS LOCATED ON REAR PANEL.
 8. C28, 2.2UF IS NOT INSTALLED.
 9. S2 IS LOCATED ON FRONT PANEL.
 10. +5 VOLT SUPPLY TO MOTHERBOARD AND OPTIONS.

TABLE OF ACTIVE ELEMENTS
P/O A1 ASSEMBLY

C27-32, 34-36, 69-71, 79
CR8-14
E1
F1, 2
J3, 4, 9
L1, 6, 7
M1
Q10-12
R50, 52, 55-64
S1, 2
T1
TP2, 8-10
U7-9

TABLE OF ACTIVE ELEMENTS

REFERENCE DESIGNATIONS	HP PART NUMBER	MFR. PART NUMBER
CR8	1906-0096	SDA296-2
CR9	1804-0221	SCR1153K
CR10	1902-3234	SZ30016-266
CR11	1901-0050	
CR12, 14	1901-0782	IN5021
CR13	1902-3110	SZ30017-117
Q10	1853-0033	X45H201
Q11	1854-0013	2N2218A
Q12	1854-0477	2N2222A
U7	1826-0904	LM330T
UB	1826-0544	MC1403U
U9	1826-0428	SG3524J

Figure 8-50. HP 5384A A1 Motherboard Assembly (Sheet 2 of 2)

Figure 8-51

HP 5385A A1 MOTHERBOARD ASSEMBLY

(Sheet 1 of 2)

(See Page 8-51)

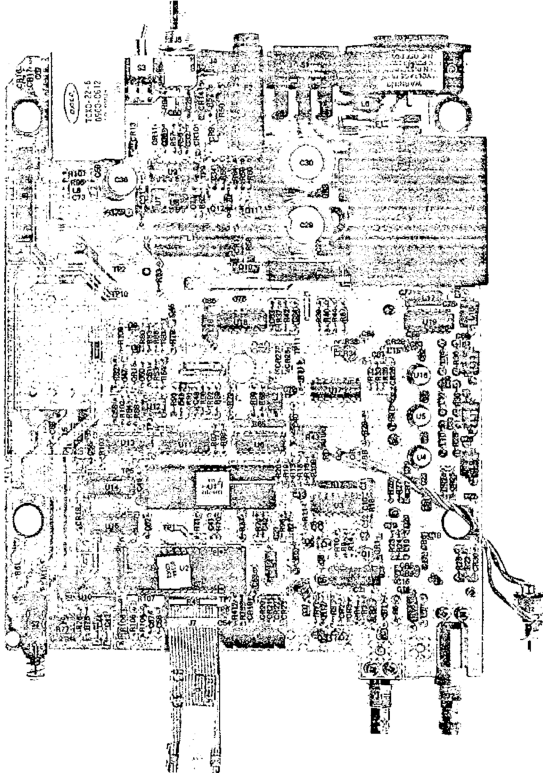

1310-22-5
0500-0512

TO: [illegible]
FROM: [illegible]
SUBJECT: [illegible]

- 1
- 2
- 3
- 4
- 5
- 6
- 7
- 8
- 9
- 10
- 11
- 12
- 13
- 14
- 15
- 16
- 17
- 18
- 19
- 20
- 21
- 22
- 23
- 24
- 25
- 26
- 27
- 28
- 29
- 30
- 31
- 32
- 33
- 34
- 35
- 36
- 37
- 38
- 39
- 40
- 41
- 42
- 43
- 44
- 45
- 46
- 47
- 48
- 49
- 50



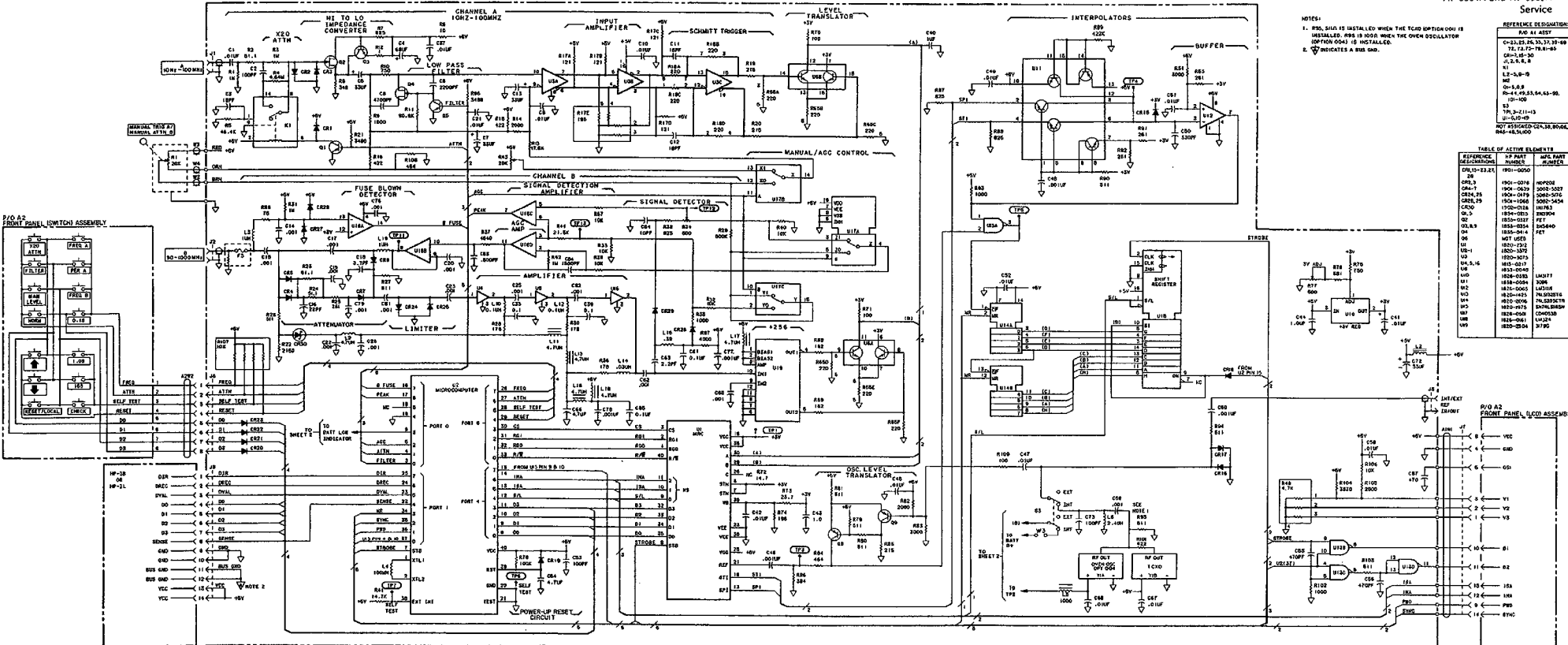

NOTES:

1. R92, S111 IS INSTALLED WHEN THE FC00 OPTION 004 IS INSTALLED. R93 IS INSTALLED WHEN THE OVEN OSCILLATOR (OPTION 004) IS INSTALLED.
2. ∇ INDICATES A BUS SW.

REFERENCE DESIGNATIONS

AO A1 TEST
 C=23,25,26,31,37,39-49
 D=1,18-20
 E=1,2,5,6,8
 F=1
 G=1,2,3,8-9
 H=2
 J=1-5,8
 K=4,5,9,33,44,53-58
 L=10-100
 M=1
 N=3
 P=2-21-1-3
 Q=1-10-10-10
 R=1
 S=1
 T=1
 U=1
 V=1
 W=1
 X=1
 Y=1
 Z=1

NOT ASSIGNED: G2,10,30,60,61, 84,85,86,90

TABLE OF ACTIVE ELEMENTS

REFERENCE DESIGNATION	IC PART NUMBER	IC PART NUMBER	MFG. PART NUMBER
CR10-23,25	1901-0050		
CR11	1901-0050		
CR12	1901-0050		
CR13	1901-0050		
CR14	1901-0050		
CR15	1901-0050		
CR16	1901-0050		
CR17	1901-0050		
CR18	1901-0050		
CR19	1901-0050		
CR20	1901-0050		
CR21	1901-0050		
CR22	1901-0050		
CR23	1901-0050		
CR24	1901-0050		
CR25	1901-0050		
CR26	1901-0050		
CR27	1901-0050		
CR28	1901-0050		
CR29	1901-0050		
CR30	1901-0050		
CR31	1901-0050		
CR32	1901-0050		
CR33	1901-0050		
CR34	1901-0050		
CR35	1901-0050		
CR36	1901-0050		
CR37	1901-0050		
CR38	1901-0050		
CR39	1901-0050		
CR40	1901-0050		
CR41	1901-0050		
CR42	1901-0050		
CR43	1901-0050		
CR44	1901-0050		
CR45	1901-0050		
CR46	1901-0050		
CR47	1901-0050		
CR48	1901-0050		
CR49	1901-0050		
CR50	1901-0050		
CR51	1901-0050		
CR52	1901-0050		
CR53	1901-0050		
CR54	1901-0050		
CR55	1901-0050		
CR56	1901-0050		
CR57	1901-0050		
CR58	1901-0050		
CR59	1901-0050		
CR60	1901-0050		
CR61	1901-0050		
CR62	1901-0050		
CR63	1901-0050		
CR64	1901-0050		
CR65	1901-0050		
CR66	1901-0050		
CR67	1901-0050		
CR68	1901-0050		
CR69	1901-0050		
CR70	1901-0050		
CR71	1901-0050		
CR72	1901-0050		
CR73	1901-0050		
CR74	1901-0050		
CR75	1901-0050		
CR76	1901-0050		
CR77	1901-0050		
CR78	1901-0050		
CR79	1901-0050		
CR80	1901-0050		
CR81	1901-0050		
CR82	1901-0050		
CR83	1901-0050		
CR84	1901-0050		
CR85	1901-0050		
CR86	1901-0050		
CR87	1901-0050		
CR88	1901-0050		
CR89	1901-0050		
CR90	1901-0050		
CR91	1901-0050		
CR92	1901-0050		
CR93	1901-0050		
CR94	1901-0050		
CR95	1901-0050		
CR96	1901-0050		
CR97	1901-0050		
CR98	1901-0050		
CR99	1901-0050		
CR100	1901-0050		

Figure 8-51. HP 5385A A1 Motherboard Assembly (Sheet 1 of 2)

Figure 8-51

HP 5385A A1 MOTHERBOARD ASSEMBLY

(Sheet 2 of 2)

(See Page 8-53)

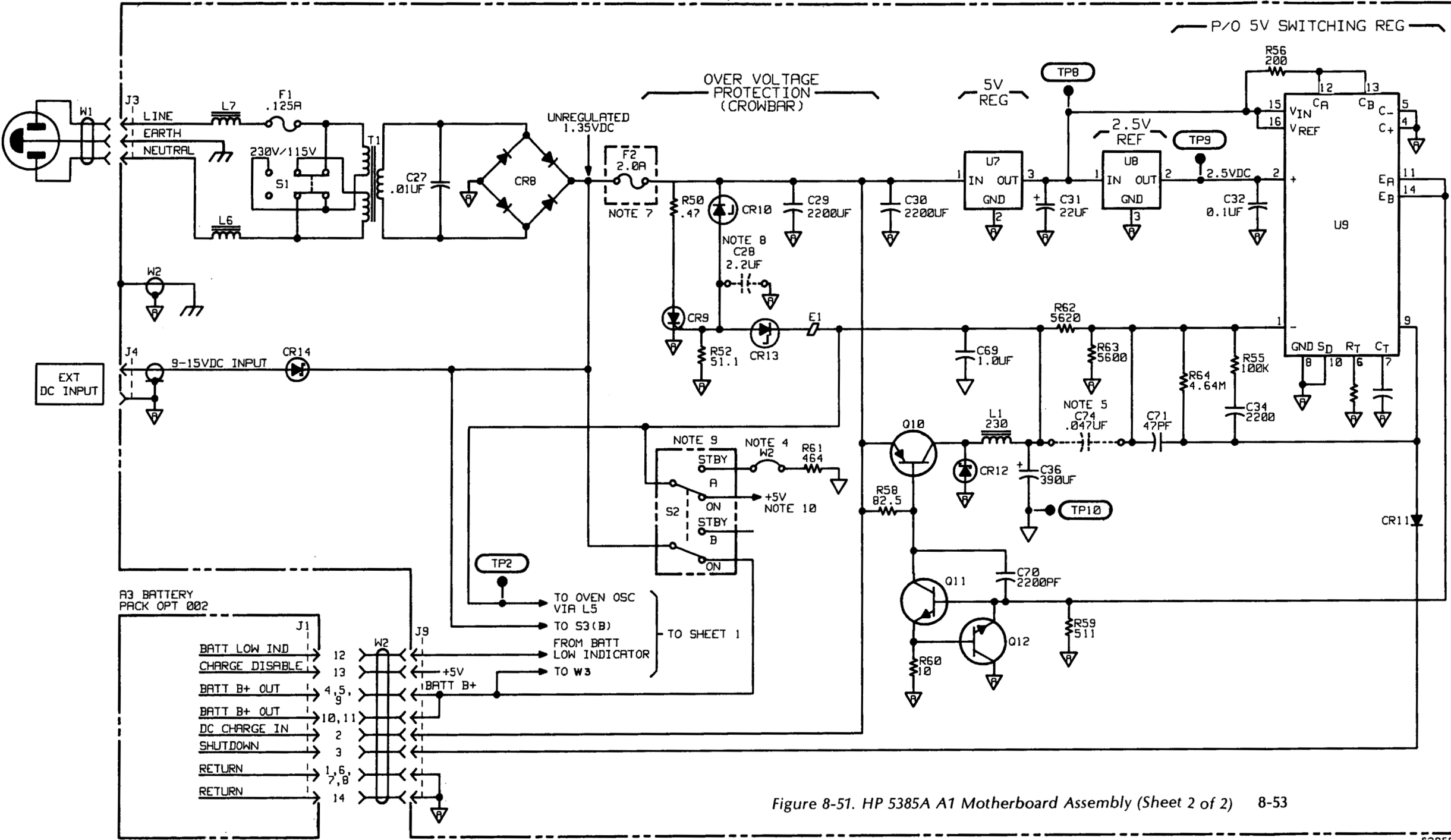

- NOTES
1. REFERENCE DESIGNATIONS WITHIN THIS ASSEMBLY ARE ABBREVIATED. ADD ASSEMBLY NUMBER TO ABBREVIATION FOR COMPLETE DESCRIPTION.
 2. UNLESS OTHERWISE INDICATED:
RESISTANCE IN OHMS;
CAPACITANCE IN MICROFARADS;
INDUCTANCE IN MICROHENRIES.
 3. ASTERISK (*) INDICATES SELECTED COMPONENT, AVERAGE VALUES SHOWN.
 4. JUMPER W2 IS REMOVED WHEN OPTION 004 IS INSTALLED.
 5. C74, .047UF IS NOT INSTALLED.
 6. ▽ INDICATES A COMMON CONNECTION.
 7. F2 IS LOCATED ON REAR PANEL.
 8. C28, 2.2UF IS NOT INSTALLED.
 9. S2 IS LOCATED ON FRONT PANEL.
 10. +5 VOLT SUPPLY TO MOTHERBOARD AND OPTIONS.

TABLE OF ACTIVE ELEMENTS
P/O A1 ASSEMBLY

C27-32, 34-36, 69-71, 79
CR8-14
E1
F1, 2
J3, 4, 9
L1, 6, 7
M1
Q10-12
R50, 52, 55-64
S1, 2
T1
TP2, 8-10
U7-9

TABLE OF ACTIVE ELEMENTS

REFERENCE DESIGNATIONS	HP PART NUMBER	MFR. PART NUMBER
CR8	1906-0096	SDA296-2
CR9	1804-0221	SCR1153K
CR10	1902-3234	SZ30016-266
CR11	1901-0050	
CR12, 14	1901-0782	IN5821
CR13	1902-3110	SZ30017-117
Q10	1853-0363	X45H2B1
Q11	1854-0013	2N218A
Q12	1854-0477	2N2222A
U7	1826-0904	LM330T
UB	1826-0544	MC1403U
US	1826-0428	SG3524J

Figure 8-51. HP 5385A A1 Motherboard Assembly (Sheet 2 of 2) 8-53

Figure 8-52

A5 HP-IB INTERFACE ASSEMBLY

(See Page 8-55)

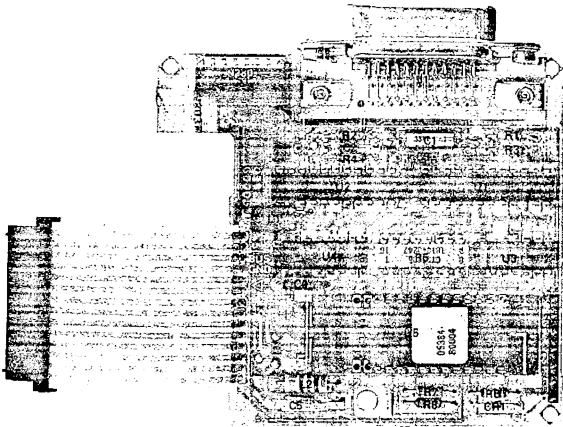

05384
80004

05384
80004

CS

TR
CR

TR
CR

Figure 8-53

A4 HP-IL INTERFACE ASSEMBLY

(See Page 8-57)

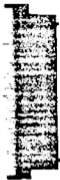
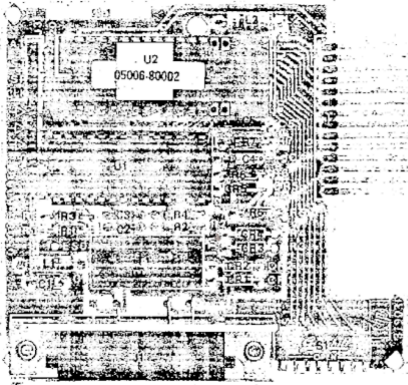
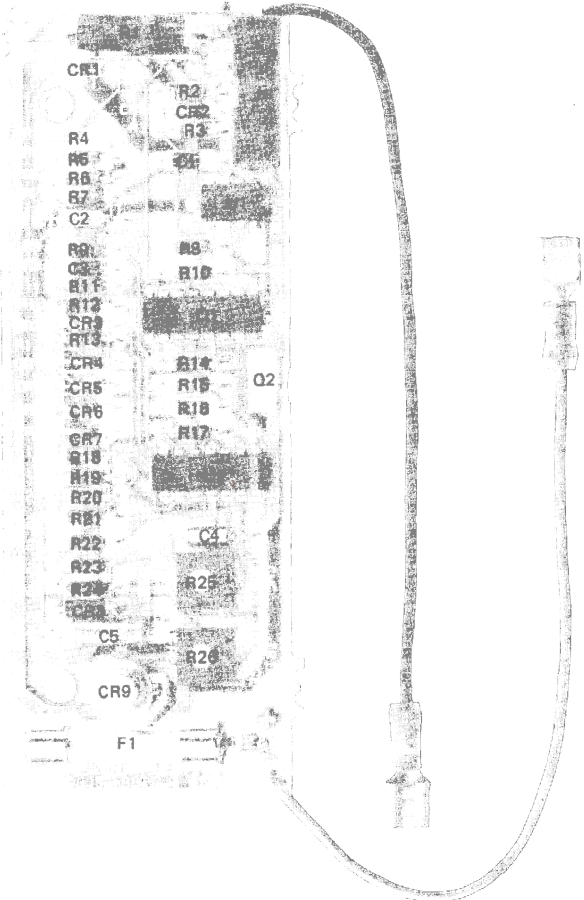
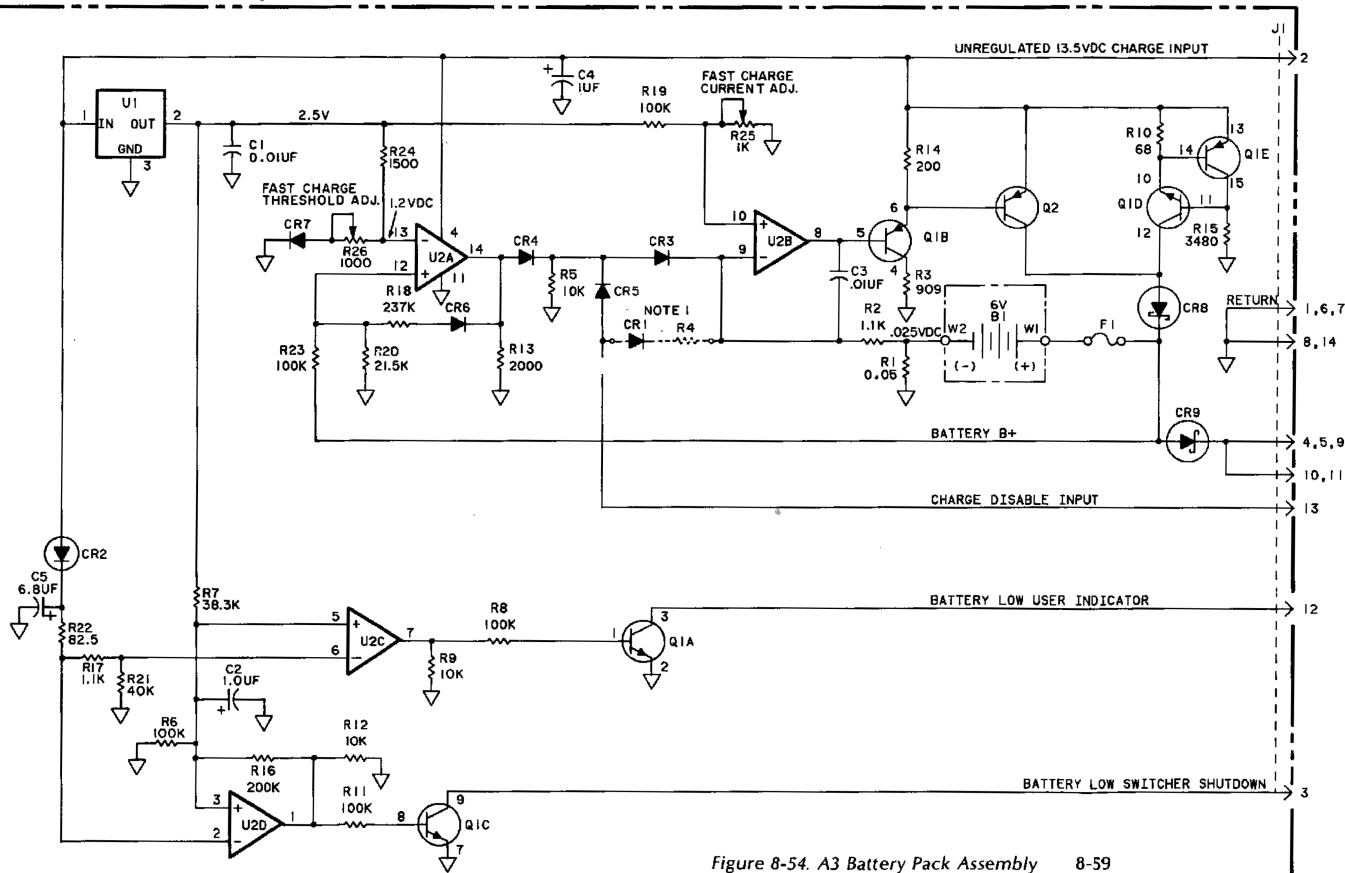

Figure 8-54

A3 BATTERY PACK ASSEMBLY

(See page 8-59)





TO AIJ9

NOTES
1. CR1 AND R4 NOT INSTALLED.

REFERENCE DESIGNATIONS

A3 ASSY	
BI	
CI-5	
CR1-9	
F1	
J1	
Q1, 2	
R1-26	
U1, 2	
W1, 2	

TABLE OF ACTIVE ELEMENTS

REFERENCE DESIGNATIONS	HP PART NUMBER	MFG PART NUMBER
CR1-7	1901-0050	FDH6308
CR8	1901-1080	IN5817
CR9	1901-0676	SBD5041
Q1	1858-0054	CA3096E-06
Q2	1853-0363	X45H281
U1	1826-0544	SC7657/LK
U2	1826-0161	LM324N

Figure 8-54. A3 Battery Pack Assembly 8-59

MANUFACTURER'S DECLARATION

NOTE

This is to certify that this product meets the radio frequency interference requirements of Directive FTZ 1046/1984. The German Bundespost has been notified that this equipment was put into circulation and has been granted the right to check the product type for compliance with these requirements.

Note: If test and measurement equipment is operated with unshielded cables and/or used for measurements on open setups, the user must insure that under these operating conditions, the radio frequency interference limits are met at the border of his premises.

NOTE

Hiermit wird bescheinigt, dass dieses Gerät/System in Übereinstimmung mit den Bestimmungen von Postverfügung 1046/84 funkentstört ist.

Der Deutschen Bundespost wurde das Inverkehrbringen dieses Gerätes/Systems angezeigt und die Berechtigung zur Überprüfung der Serie auf Einhaltung der Bestimmungen eingeräumt.

Zusatzinformation für Mess- und Testgeräte:

Werden Mess- and Testgeräte mit ungeschirmten Kabeln und/oder in offenen Messaufbauten verwendet, so ist vom Betreiber sicherzustellen, dass die Funk-Entstörbestimmungen unter Betriebsbedingungen an seiner Grundstücksgrenze eingehalten werden.